

CATÁLOGO

TARIFA

CATALOGUE

RATE

CATALOGUE

TARIF

2

0

2

2



EQUIPAMIENTO ALIMENTACIÓN Y HOSTELERÍA



J2, VOCACIÓN POR EL BUEN HACER

1980, nace J2 importaciones y distribuciones una empresa con carácter familiar que originalmente se centra en la fabricación y distribución de carteles y bandejas para la industria alimentaria y el sector hostelero. Rápidamente son añadidos nuevos productos como: tacos y pilones, polietileno, picadoras, máquinas de vacío, retractiladoras, cuchillos, ganchos, hamburgueseras, exterminadores de insectos, cubetas gastronorm, taquillas, indicadores "su turno"... todo ello fruto de la gran demanda e inquietud por poder ofrecer a nuestros distribuidores todo lo que necesiten.

Actualmente J2 es una empresa consolidada y reconocida en la industria alimentaria y el sector hostelero, con más de 2500 referencias que se pueden encontrar en nuestro catálogo.

J2 plantea el futuro con ilusiones renovadas. Un equipo joven y dinámico afronta los nuevos retos y oportunidades que genera la globalización. Nuestra inquietud por innovar nos lleva a visitar y exponer en las principales ferias del sector en Europa, para conocer los avances del sector. Nuestra amplia experiencia en importación y distribución nos permite garantizar un producto actual, de calidad y duradero para nuestros distribuidores.

J2, CALLING FOR DOING GOOD

In 1980 is born J2 imports and distributions as a company with family character, originally focused on manufacturing and distribution of tags and trays for the food industry and the hospitality industry. They are quickly added new products such as gashes and pylons, polyethylene, choppers, vacuum machines, shrink wrapping, knives, hooks, hamburger-maker, bug zappers, Gastronorm containers, lockers, indicators "turn"... all the result of the great demand and concern to offer our distributors everything they need.

Currently J2 is an established and recognized company in the food industry and the hospitality industry, with over 2,500 references that can be found in our catalog.

J2 raises the future with renewed hopes. A young and dynamic team faces new challenges and opportunities created by globalization. Our concern for innovation leads us to visit and exhibit at the main trade fairs in Europe, to the progress of the sector. Our extensive experience in import and distribution allows us to guarantee a current product, quality and durable for our distributors.

J2, VOCATION ET SAVOIR FAIRE

1980 né la Société J2 importaciones y distribuciones avec un caractère familial et initialement axée sur la fabrication et la distribution d'affiches et de plateaux pour l'industrie alimentaire et l'industrie hôtelière. Ils sont rapidement ajoutés de nouveaux produits tels que les este filades et les pylônes, le polyéthylène, hachoirs, machines à vide, film rétractable, des couteaux, des crochets, ex terminateurs d'insectes, les conteneurs Gastronorm, des casiers, des indicateurs "tour"... tout le résultat de la grande demande et préoccupation d'offrir à nos distributeurs tout ce dont ils ont besoin.

Actuellement J2 est une société établie et reconnue dans l'industrie alimentaire et l'industrie hôtelière, avec plus de 2500 références peuvent être trouvées dans notre catalogue.

J2 soulève l'avenir avec de nouveaux espoirs. Une équipe jeune et dynamique face à de nouveaux défis et opportunités créées par la mondialisation. Notre souci d'innovation nous amène à visiter et d'exposer les principales foires commerciales en Europe, au progrès du secteur. Notre vaste expérience dans l'importation et la distribution nous permet de garantir un produit courant, la qualité et durable pour nos distributeurs.

0 1

Tajos, Tacos sobre mostrador, Pilones, Trípodes, Polietileno, Mesas de madera, Mesas acero-inox, Complementos, Polietileno mesa-cocina, Palas polietileno, Soportes tablas polietileno.

Chopping block tables, cutting boards on counters, Polyethylene, Wooden tables, Stainless steel tables, Accessories, Kitchen table polyethylene, Polyethylene utility paddles, Polyethylene board stand.

Billots de boucher, Blocs sur comptoir, Polyéthylènes, Tables en bois, Tables en acier-inox, Accessoires, Poléthylène table-cuisine, Pelles polyéthylène, Supports table polyéthylène.

1 - 20

0 2

Carteles portaprecios, Peana - Plataformas - Pinzas, Listas de precios, Carteles señalización, Guirnalda, Separadores, Barreños, Base rodante, Cubetas, Bandejas, Gastronorm, PlexiLine.

Price tag holder, Stand - platforms - Clips, Price lists, Sign, Garlands, Separators, Tubs, Rolling base, Containers, Trays, Gastronorm, PlexiLine.

Affiches porte prix, Socle - plate-formes - clips, Liste prix, Affiches signalization, Guirlandes, Séparateurs, Bassines, Base roulante, Bacs, Plateaux, Gastronorm, PlexiLine.

21 - 62

0 3

Picadoras, Picadora refrigerada, Cuchillas Placas, Empujadores picadoras, Cortadoras, Ralladora, Exprimidor, Cortadora multifunción, Entenercedor de carne, Cutters, Molino, Afiladoras, Cintas de sierra.

Mincers, Refrigerated mincers, Blades plates, Mincer pusher, Slicer, Grater, Juicer, Multi-purpose slicer, Meat tenderizer, Cutters, Mill, Sharpener, Band saws.

Hachoirs, Hachoirs réfrigérés, Lames plaques, Poussoir hachoirs, Trancheuse, Râpes, Presse, Decoupoir multifonction, Attendrissant, Cutter, Moulin, Aiguiseur, Scies à ruban.

63 - 86

0 4

Maquinas retractilar, Film, Dispensadores de film, Dispensador papel aluminio, Soldadoras de bolsas, Máquina sellar, Máquina vacío, Parrilla envasadora, Bolsas vacío, Termoselladora.

Wrapping machines, Film, Film dispensers, Aluminium foil dispenser, Bag sealer, Sealer machine, Vacuum machine, Packaging grill, Vacuum bags, Thermo sealer.

Machine à retractiler, Film, Dispensateurs film, Dispensateur papier aluminium, Scelleuse de sacs, Machine à sceller, Machine vide, Grill à sceller, Sacs sous vide, Thermo machine.

87 - 100

0 5

Secamanos, Dispensadores papel celulosa, Papel celulosa, Dosificadores jabón, Grifos - caño electrónico, Grifos ducha, Lavamanos, Portacuchillos - Papeleras, Esterilizadores de cuchillos, Contenedores plástico, Contenedores papeleras acero-inoxidable, Cañón de ozono.

Hand dryer, Cellulose paper dispenser, Cellulose paper, Soap dispensers, Tap with electronic spout, Shower tap, Washbin, Knife holder - Waste baskets, Knives sterilizer, Plastic container, Stainless steel containers-bins, Ozone cannon.

Sèche-mains, Dispensateur papier cellulose, Papier cellulose, Doseurs de savon, Robinet électronique, Robinet douche, Lave - mains, Porte couteaux - Poubelles, stérilisateur de couteaux, Conteneurs plastique, Conteneur-poubelle acier inox, Canon à ozone.

101 - 120

0 6

Indicadores de turno, Expendedores de tickets, Impresora de tickets, Rollo tickets, Organizador de filas, Exterminadores de insectos, Detector contador billetes - monedas, Reloj-temperatura.

Queue indicators, Ticket dispenser, Tickets printer, Ticket roll, Row organizer, Insect exterminator, Counter detector bill - coin, Clock - temperature.

Indicateur de numero, Dispensateur tickets, Imprimante tickets, Rouleaux de tickets, Organisateur de rangée, Exterminateur d'insectes, Compteur détecteur billets - monnaie, Horloge - température.

121 - 134

0 7

Hamburgueseras, Papel celofán, Embutidoras, Jamoneras, Jamonero rotatorio 360°, Ganchos, Libradores, Pinzas, Molde brochetas, Entenercedor carne, Malla y anillas elásticas, Protector hueso, Termómetros.

Hamburger presses, Cellophane foil, Sausage filler, Jamoneras, Rotary Ham holder 360°, Hooks, Scoops, Tongs, Brochette mold, Meat tenderizer, Elastic mesh and rings, Bone protector, Thermometer.

Hachoirs, Papiers cellophane, Emboutisseuses, Jamoneras, Support de jambon rotatif 360°, Crochets, Pelles à main, Pincas, Moule brochettes, Attendrisseur, Maille et anneaux élastiques, Protecteur d'os, Thermomètre.

135 - 148

0 8

Cierra bolsas - rollos, Etiquetadoras-rollos, Navateadoras, Espejos vigilancia, Carro servicio - Bandejero, Cestos - carros autoservicio, Dispensadores bolsas, Carros Gastronorm.

Bag-roll sealer, Labellers-rolls, Labelling gun, Vigilance mirror, Service trolley - tray, Self-service basket - trolley, Bags dispensers, Gastronorm trolley.

Machines ferme sacs, Étiquetteuses-rolls, Pistolet à étiqueter, Miroir de surveillance, Chariot service - Plateau, Panier - chariot self-service, Dispensateurs sacs, Chariot Gastronorm.

149 - 160

0 9

Cuchillería profesional, Afiladores, Chairas, Hachas, Tijeras, Espátulas, Bacaladera, Abre-Ostras, Sierras, Imanes, Guillotinas queso, Sacacorchos, Abrelatas, Guantes, Delantes, Material de un uso, Delantales protección, Guantes frío, Guantes malla acero-inox, Guantes y manoplas calor.

Professional knives, Sharpeners, Axes, Scissors, Spatulas, Fish shears, Oyster sucker, Saws, Magnets, Cheese guillotines, Corkscrew, Can openers, Gloves, Aprons, Disposable material, Protective aprons, Cold gloves, Mesh steel-stainless gloves, Gloves and mittens heat.

Couteaux professionnels, Aiguiseurs, Scies, Ciseaux, Spatules, Moorutiel manuel, Couteau à huîtres, Scies, Aimants, Guillotines à fromage, Tire-Bouchon, Ouvre-Boîtes, Gants, Tabliers, Material d'un seul usage, Tabliers de protection, Gants froid, Gants en acier inoxydable, Gants et mitaines chaleur.

161 - 182

1 0

Estanterías, Plataformas, Tarima antifatiga, Palets, Losetas, Bancos de vestuario, Taquillas.

Shelves, Platforms, Anti-fatigue may, Pallets, Tiles, Locker room bench, Lockers.

Étagères, Plate-formes, Sol anti-fatigue, Palettes, Carreaux, Banc vestiaire, Casiers.

183 - 196

Recambios / Spare Parts / Pieces de Rechange

Carteles portaprecios, Guantes acero-inox, Indicadores de turno, Grifos ducha, Soldadores de bolsa, Esterilizadores, Máquinas retractilar, Máquinas cierra bolsas, Hamburgueseras, Máquinas cierra bolsas, Etiquetadoras, Abrelatas, Exterminadores-tubos.

Tag holders, Stainless steel gloves, Queue indicators, Shower taps, Bag sealers, Sterilisers, Wrapping machines, Burger presses, Labellers, Can opener, Insect exterminators-tubes.

Affiches porte-prix, Gants d'inox, Indicateurs de tour, Robinets douche, Scelleuse de sacs, Stérilisateurs, Machines à retractiler, Machine ferme sacs, Hachoirs, Étiquetteuses, Ouvre-boîtes, Exterminateurs d'insectes-tubes.

197 - 202



SUBDIRECCIÓN GENERAL
DE GESTIÓN DE RIESGOS
ALIMENTARIOS
REGISTRO GENERAL
SANITARIO DE ALIMENTOS

1/1

1.	Nombre o Razon Social SACOPI SA S.L.		
2.	Domicilio Social C/ VALLES 5 (POL. IND. CAN CASABLANCAS) SANT QUIRZE DEL VALLES		BARCELONA
3.	Actividad de la Industria FABRICACION Y/O ELABORACION Y/O TRANSFORMACION DE MATERIAS PLASTICAS FABRICACION Y/O ELABORACION Y/O TRANSFORMACION DE MADERA, CORCHO, CUERO, PIELS Y FIBRAS NATURALES		
4.	Domicilio Industrial C/ VALLES 5 (POL. IND. CAN CASABLANCAS) SANT QUIRZE DEL VALLES		BARCELONA
5.	Clave 39	Categ. / Act./s 0101, 0109	Núm. Registro Sanitario 39.04434/B

De conformidad con lo dispuesto en el artículo segundo del Real Decreto 1712/1991, de 29 de noviembre (B.O.E. de 4 de diciembre), y a tenor de la autorización concedida, ha quedado inscrita la industria de referencia en el Registro General Sanitario de Alimentos con el número arriba indicado.

Madrid, 22 de Octubre de 2010

EL TÉCNICO SUPERIOR



REGISTRO GENERAL SANITARIO
DE ALIMENTOS

Miguel Ángel Casas Paulet

AREA DE AUTORIZACIONES Y REGISTROS (DIVISION DE GESTION DE RIESGOS)
AGENCIA DE PROTECCION DE LA SALUD
BARCELONA

Generalitat de Catalunya
Agència de Salut Pública de Catalunya

SACOPI SA SL
Polígon Industrial Can Casablanques sortida
CR Vallès, 5
08192 SANT QUIRZE DEL VALLÈS

D'acord amb la sol·licitud presentada i havent tramitat l'expedient corresponent, ha quedat **ACTUALITZADA** la situació de l'empresa de referència en el Registre sanitari d'indústries i productes alimentaris de Catalunya (RSIPAC), amb les dades següents:

De conformidad con la solicitud presentada y tramitado el expediente correspondiente, ha quedado **ACTUALIZADA** la situación de la empresa de referencia en el Registro Sanitario de Industrias y Productos Alimentarios de Cataluña (RSIPAC), con los datos siguientes:

IDENTIFICACIÓ DE L'EMPRESA/IDENTIFICACIÓN DE LA EMPRESA

Raó social/razón social NIF/NIE/CIF
SACOPI SA SL B60206810

Adreça social/domicilio social
Polígon Industrial Can Casablanques
CR Vallès, 5 X: 423992
08192 SANT QUIRZE DEL VALLÈS Y: 4600634

Adreça industrial/domicilio industrial
Polígon Industrial Can Casablanques
CR Vallès, 5 X: 423992
08192 SANT QUIRZE DEL VALLÈS Y: 4600634

Núm. RSIPAC: 39.05165/CAT Núm. RGSEAA: 39.04434/B

Data Inscripció/fecha inscripción: 07/09/2010

ACTIVITATS / ACTIVIDADES

Ciau: 39

Codi	Descripció
01/01	Fabricació o elaboració o transformació de matèries plàstiques
01/09	Fabricació o elaboració o transformació de fusta, suro, cuir, pells i fibres naturals

Clave: 39

Código	Descripción
01/01	Fabricación o elaboración o transformación de materias plásticas
01/09	Fabricación o elaboración o transformación de madera, corcho, cuero, pieles y fibras naturales

Roc Boronat, 81-95
Barcelona . 93 551 39 00 / Fax 93 551 75 05
<http://www.gencat.cat/salut>

SALUT

Document electrònic garantit amb signatura electrònica. Podeu verificar la integritat d'aquest document a l'adreça web csv.gencat.cat

Original electrònic / Còpia autèntica



Doc.original signat per:
CPISR-1 Maria Alba Pascual
Cardona
12/07/2016

CODI SEGUR DE VERIFICACIÓ

01DBVIPDK3N0IMSEB1W8U23LY2J4NUHL

Data creació còpia:
13/07/2016
Data caducitat còpia:
13/07/2019
Pàgina 1 de 2

**Reservamos el derecho a modificar ó alterar nuestros productos sin previo aviso.
Los precios son válidos salvo error tipográfico o de impresión.**

We reserve ourselves the right to modify our products without notice it previously.
Prices are valid except for typographical errors or printing.

*Nous rèservons le droit de modifier nos produits sans préavis.
Les prix sont valables sauf erreur typographique ou d'impression.*

0

1

Tajos, Tacos sobre mostrador, Pilonos, Trípodes, Polietilenos, Mesas de madera, Mesas acero-inox, Complementos, Polietileno mesa-cocina, Palas polietileno, Soportes tablas polietileno.

Chopping block tables, cutting boards on counters, Polyethylene, Wooden tables, Stainless steel tables, Accesories, Kitchen table polyethylene, Polyethylene utility paddles, Polyethylene board stand.

Billots de boucher, Blocs sur comptoir, Polyéthylènes, Tables en bois, Tables en acier-inox, Accessoires, Poléthylène table-cuisine, Pelles polyéthylène, Supports table polyéthylène.

1 - 19

Todos nuestros productos fabricados están elaborados con maderas de encina, acacia, plátano y haya previamente seleccionada y tratada con riguroso proceso de secado para sustraer la humedad, savia y glutinosa de la madera, dejando todas las betas limpias para que dicho producto no tenga impurezas en su interior.

Consiguiendo con este proceso que al manipular los alimentos no desprendan ningún tipo de impurezas. Para la conservación de la madera de nuestros productos fabricados, recomendamos usar nuestro rascador Ref. A-80 diariamente, para así conseguir mantener la superficie totalmente lisa y limpia.

No utilizando productos químicos que dañarian la conservación de nuestros pilones, tajos, tacos y mesas de madera. Todos los productos están autorizados por sanidad.

All our products are made with holm oak wood, previously selected and treated with a rigorous drying process to remove moisture, sap and glutinous wood, leaving all streaks clean in order to get a product with no impurities.

With this process, the food can be manipulated without any kind of impurities.

In order to get a better wood preservation of our products, we recommend using our scraper, Ref A-80, daily to keep it completely smooth and clean.

Do not use chemical products that could damage the conservation of our chopping blocks and wooden tables.

All products used are legally approved.

Tous nos produits sont fabriqués en bois de chêne vert, préalablement sélectionnés et traité avec un processus rigoureux séchage pour enlever l'humidité, le sève et le gluant du bois, en laissant tout le bois propre pour ce produit ne contienne pas d'impuretés en elle. Grâce à ce processus, lorsque vous manipulez des aliments aucune substance ne sera en dommagée.

Pour protéger le bois de nos produits, nous vous recommandons d'utiliser notre décapeuse Réf A-80 tous les jours, pour garder la surface lisse et propre. Utiliser de produits chimiques pourrait nuire à la conservation des pieds, des billots et des tables en bois.

Tous nos produits sont approuvés par le Ministère de la santé.



Ref.	Medidas Size Dimensions
EC-10	38 x 9 x 38 cm

Portacuchillos protegido, acero-inox
Con tres ranuras para cuchillos y chaira ovalada-redonda

Encased knife holder, stainless steel
Three grooves for knives and oval professional sharpener

Porte couteaux et fusil ovale rond, acier inox
Avec trois rainures pour couteaux et fusil ovale rond



Rascador
Para limpieza de pilones y tajos de madera M

Grater
Inyectado chopping blocks

Grattoir
Pour billots

Ref.
A-80



Cepillo limpieza tablas polietileno

Polyethylene cutting board brush

Brosse nettoyage planches poléthylène

Ref.
A-81

Recambio cuchilla A-81

Spare blade A-81

Lame de rechange A-81

Ref.
A-81-1



Portacuchillo de madrea

Wooden knife holder

Porte-couteaux en bois

Ref.
V-PORMAD

Portacuchillo de polietileno

Polyethylene knife holder

Porte-couteaux en polyéthène

Ref.	Color Colour Couleur
V-PORPOLB	○
V-PORPOLR	●

Portacuchillo de varilla acero-inox para tajo

Stainless steel Knife holder for block

Porte-coutaux en inox pour billot

Ref.	Tipo Type Type
V-PORACE-40	40
V-PORACE-44	44
V-PORACE-50	50

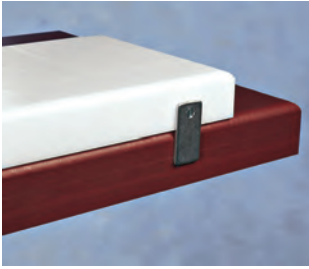

Tope valdilla acero inox

Stainless steel buffer

Bout acier inox

Ref.

V-VALDILLA

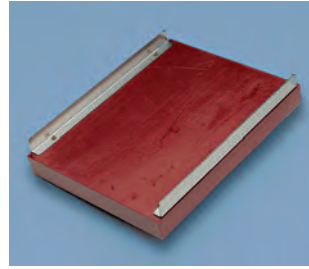

Guía tope vitrina inox

Stainless steel guides

Guides acier inox

Ref.

Medidas
Size
Dimensions

V-GUIA-40

40 x 3 x 2 cm

Pie regulable para pata inox

Adjustable foot for stainless steel legs

Pieds réglables pour inox pattes

Ref.

V-PR

Goma antideslizante

Stopper antiskid

Gomme antidérapante

Ref.

V-GOMA

Pie fijo para patas inox

Fixed foot for stainless legs

Pieds fixes pour inox pattes

Ref.

V-PF

TAJOS DE 4 PATAS CON TACO MADERA | CHOPPING BLOCKS WITH 4 LEGS | BILLOTS AVEC 4 PIEDS



**A - Tajo de 4 patas madera
Sin portacuchillos. Altura total 90 cms.**

A - 4-leg wooden chopping block table
Without knife holder. Total height 90 cm.

*A - Billot de boucher 4 pattes bois
Sans porte couteaux. Hauteur totale 90 cm.*

Ref.	Medida taco Cutting board size Mesure bloc
V-A604025E	60 x 40 x 25 cm
V-A644425E	64 x 44 x 25 cm
V-A705025E	70 x 50 x 25 cm
V-A804025E	80 x 40 x 25 cm
V-A884425E	88 x 44 x 25 cm
V-A1005025E	100 x 50 x 25 cm

Ref.	Medida taco Cutting board size Mesure bloc
V-A404025E	40 x 40 x 25 cm
V-A444425E	44 x 44 x 25 cm
V-A505025E	50 x 50 x 25 cm

Ref.	Medida taco Cutting board size Mesure bloc
V-A404015E	40 x 40 x 15 cm
V-A443215E	44 x 32 x 15 cm
V-A604015E	60 x 40 x 15 cm
V-A806015E	80 x 60 x 15 cm



I - Tajo de 4 Pata de acero inox con faldón Sin portacuchillos. Altura total 90cms.

I - Chopping block with 4 stainless steel legs with drawer
Whithout knifeholder. Total height 90 cm.

I - Billots avec 4 pieds en inox avec jupe Sans porte couteaux. Hauteur totale 90 cm.

Ref.	Medida taco Cutting board size Mesure bloc
V-1404025E	40 x 40 x 25 cm
V-1444425E	44 x 44 x 25 cm
V-1505025E	50 x 50 x 25 cm
V-1604025E	60 x 40 x 25 cm

Ref.	Medida taco Cutting board size Mesure bloc
V-1644425E	64 x 44 x 25 cm
V-1705025E	70 x 50 x 25 cm
V-1804025E	80 x 40 x 25 cm
V-1884425E	88 x 44 x 25 cm
V-11005025E	100 x 50 x 25 cm



I-2 - Tajo de 4 patas de acero-inox sin faldón Sin portacuchillos. Altura total 90 cms.

I-2 - Chopping block with 4 stainless legs without drawer
Without knife holder. Total height 90 cm.

I-2 - Billots avec 4 pieds en inox sans jupe Sans porte couteaux. Hauteur totale 90 cm.

Ref.	Medida taco Cutting board size Mesure bloc
V-12404025E	40 x 40 x 25 cm
V-12444425E	44 x 44 x 25 cm
V-12505025E	50 x 50 x 25 cm
V-12604025E	60 x 40 x 25 cm

Ref.	Medida taco Cutting board size Mesure bloc
V-12644425E	64 x 44 x 25 cm
V-12705025E	70 x 50 x 25 cm
V-12804025E	80 x 40 x 25 cm
V-12884425E	88 x 44 x 25 cm
V-121005025E	100 x 50 x 25 cm



S - Tajo de 4 patas insonorizado de acero-inox Sin portacuchillo. Altura total 90 cms.

S - 4-legs stainless steel sound proof anti-vibration chopping block table Without knife holder. Total height 90 cm.

S - Billot avec 4 pieds acier inox insonorisé antivibratoire. Sans porte couteaux. Hauteur totale 90 cm.

Ref.	Medida taco Cutting board size Mesure bloc
V-S443225E	44 x 32 x 25 cm
V-S444425E	44 x 44 x 25 cm
V-S604025E	60 x 40 x 25 cm
V-S705025E	70 x 50 x 25 cm

TACOS DE MADERA | CHOPPING BLOCKS | BILLOTS



O - Tacos de madera cuadrados

O - Square cutting boards

O - Blocs carrés

Ref.	Medidas Size Dimensions
V-O404015E	40 x 40 x 15 cm
V-O404025E	40 x 40 x 25 cm
V-O444410E	44 x 44 x 10 cm
V-O444420E	44 x 44 x 20 cm
V-O444425E	44 x 44 x 25 cm
V-O505025E	50 x 50 x 25 cm



O - Tacos de madera redondos

O - Round cutting boards

O - Blocs ronds

Ref.	Diámetro Diameter Diamètre	Altura Height Hauteur
V-O3510E	Ø 35 cm	10 cm
V-O3515E	Ø 35 cm	15 cm
V-O3520E	Ø 35 cm	20 cm



G - Tacos de madera rectangulares

G - Rectangular cutting boards

G - Blocs rectangulaires

Ref.	Medidas Size Dimensions
V-G443210E	44 x 32 x 10 cm
V-G443215E	44 x 32 x 15 cm
V-G443220E	44 x 32 x 20 cm
V-G443225E	44 x 32 x 25 cm

Ref.	Medidas Size Dimensions
V-G604025E	60 x 40 x 25 cm
V-G644425E	64 x 44 x 25 cm
V-G705025E	70 x 50 x 25 cm
V-G804025E	80 x 40 x 25 cm
V-G884425E	88 x 44 x 25 cm
V-G1005025E	100 x 50 x 25 cm
V-G604015E	60 x 40 x 15 cm
V-G806015E	80 x 60 x 15 cm

Tabla de corte en madera

Wooden cutting board

Planche à découper en bois



Ref.	Medidas Size Dimensions
V-T50355	50 x 35 x 4,2 cm
V-T50405	50 x 40 x 4,2 cm



B - Pilón graduable descentrado expox
Altura pie mínima 65 máxima 110 cm. Modelo ideal para espacios reducidos, trabajando la parte superior por encima del mostrador, evitando perjudicar con el golpe la vitrina. Al mismo tiempo aprovechamos la anchura del pasillo. Graduación a la altura de corte desea. Colocación: 4 tornillos al suelo. Se puede montar con tacos cuadrados ó polietileno.

B - Adjustable decentred epoxy leg
 Minimum leg height 65, maximum 110 cm. An ideal model for cramped spaces, enables you to work on top of the counter thus avoiding any damage to glass display. It also gives you more room behind the counter. Adjustable to the desired chopping height. Placing: 4 screws on the floor. Can be assembled with square blocks or polyethylene.

B - Pied réglable décentré époxy
 Hauteur pied minimum 65, maximum 110 cm. Modèle idéal pour les espaces réduits, pour travailler sur la partie supérieure du comptoir en évitant de porter un coup à la vitrine. Nous profitons du même coup de la largeur du couloir. Réglable à l' hauteur de coupe désirée. Lieu: 4 vis sur le sol. Il peut être monté avec billots carrés.

Ref.

V-BPGD



B - Pilón graduable descentrado acero-inox
Altura pie mínima 80, máxima 105 cm. Modelo ideal para espacios reducidos, trabajando la parte superior por encima del mostrador, evitando perjudicar con el golpe la vitrina. Al mismo tiempo aprovechamos la anchura del pasillo. Graduación a la altura de corte deseada. Colocación: 4 tornillos al suelo. Se puede montar con tacos cuadrados o redondos.

B - Adjustable decentred stainless steel leg
 Minimum leg height 80, maximum 105 cm. An ideal model for cramped spaces, enables you to work on top of the counter thus avoiding any damage to glass display. It also gives you more room behind the counter. Adjustable to the desired chopping height. Placing: 4 screws on the floor. Can be assembled with square or round blocks.

B - Pied réglable décentré acier inox
 Hauteur pied minimum 80, maximum 105 cm. Modèle idéal pour les espaces réduits, pour travailler sur partie supérieure du comptoir en évitant de porter un coup à la vitrine. Nous profitons du même coup de la largeur du couloir. Réglable à l' hauteur de coupe désirée. Lieu: 4 vis sur le sol. Il peut être monté avec billis carrés ou ronds.

Ref.

V-BPGDI

**H - Tablas de polietileno
Grosor 1,5 cm**

H - Polyethylene boards
Thickness 1.5 cm

H - Plaques en polyéthylène
Épaisseur 1,5 cm

Ref.	Medidas Size Dimensions
V-H25191.5	25 x 19
V-H30201.5	30 x 20
V-H33191.5	33 x 19
V-H33331.5	33 x 33
V-H40201.5	40 x 20
V-H40251.5	40 x 25
V-H40301.5	40 x 30
V-H40331.5	40 x 33
V-H40401.5	40 x 40
V-H50251.5	50 x 25
V-H50301.5	50 x 30
V-H50331.5	50 x 33
V-H50401.5	50 x 40
V-H50501.5	50 x 50
V-H60251.5	60 x 25
V-H60301.5	60 x 30
V-H60331.5	60 x 33
V-H60401.5	60 x 40
V-H75251.5	75 x 25
V-H75331.5	75 x 33
V-H100251.5	100 x 25
V-H100331.5	100 x 33
V-H150251.5	150 x 25
V-H150331.5	150 x 33
V-H200251.5	200 x 25
V-H200331.5	200 x 33
V-H2001001.5	200 x 100

**H - Tablas de polietileno
Grosor 2 cm**

H - Polyethylene boards
Thickness 2 cm

H - Plaques en polyéthylène
Épaisseur 2 cm

Ref.	Medidas Size Dimensions
V-H25192	30 x 20
V-H30202	30 x 20
V-H33192	33 x 19
V-H33332	33 x 33
V-H40202	40 x 20
V-H40252	40 x 25
V-H40302	40 x 30
V-H40332	40 x 33
V-H40402	40 x 40
V-H50252	50 x 25
V-H50302	50 x 30
V-H50332	50 x 33
V-H50402	50 x 40
V-H50502	50 x 50
V-H60252	60 x 25
V-H60302	60 x 30
V-H60332	60 x 33
V-H60402	60 x 40
V-H75252	75 x 25
V-H75332	75 x 33
V-H100252	100 x 25
V-H100332	100 x 33
V-H150252	150 x 25
V-H150332	150 x 33
V-H200252	200 x 25
V-H200332	200x 33
V-H2001002	200 x 100

**H - Tablas de polietileno
Grosor 3 cm**

H - Polyethylene boards
Thickness 3 cm

H - Plaques en polyéthylène
Épaisseur 3 cm

Ref.	Medidas Size Dimensions
V-H25193	25 x 19
V-H30203	30 x 20
V-H33193	33 x 19
V-H33333	33 x 33
V-H40203	40 x 20
V-H40253	40 x 25
V-H40303	40 x 30
V-H40333	40 x 33
V-H40403	40 x 40
V-H50253	50 x 25
V-H50303	50 x 30
V-H50333	50 x 33
V-H50403	50 x 40
V-H50503	50 x 50
V-H60253	60 x 25
V-H60303	60 x 30
V-H60333	60 x 33
V-H60403	60 x 40
V-H75253	75 x 25
V-H75333	75 x 33
V-H100253	100 x 25
V-H100333	100 x 33
V-H150253	150 x 25
V-H150333	150 x 33
V-H200253	200 x 25
V-H200333	200 x 33
V-H2001003	200 x 100

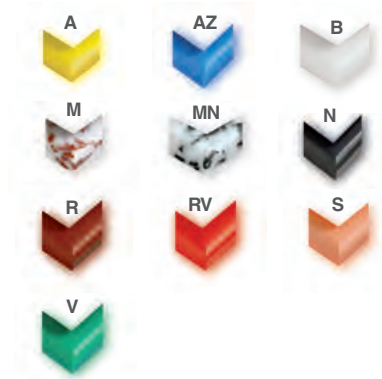

MN= Marmóreo N/B / Marmorean / Marmoréen
M= Marmóreo R/B / Marmorean / Marmoréen
B= Blanco / White / Blanc

A= Amarillo / Yellow / Jaune
S= Salmón / Salmon / Saumon
R= Rojo / Red / Rouge

V= Verde / Green / Vert
AZ= Azul / Blue / Bleu
N= Negro / Black / Noir

RV= Rojo Vivo / Light Red / Rouge Vivant

**H - Tablas de polietileno
Grosor 4 cm**

H - Polyethylene boards
Thickness 4 cm

H - Plaques en polyéthylène
Épaisseur 4 cm

Ref.	Medidas Size Dimensions
V-H25194	25 x 19
V-H30204	30 x 20
V-H33194	33 x 19
V-H33334	33 x 33
V-H40204	40 x 20
V-H40254	40 x 25
V-H40304	40 x 30
V-H40334	40 x 33
V-H40404	40 x 40
V-H50254	50 x 25
V-H50304	50 x 30
V-H50334	50 x 33
V-H50404	50 x 40
V-h50504	50 x 50
V-H60254	60 x 25
V-H60304	60 x 30
V-H60334	60 x 33
V-H60404	60 x 40
V-H75254	75 x 25
V-H75334	75 x 33
V-H100254	100 x 25
V-H100334	100 x 33
V-H150254	150 x 25
V-H150334	150 x 33
V-H200254	200 x 25
V-H200334	200 x 33
V-H2001004	200 x 100

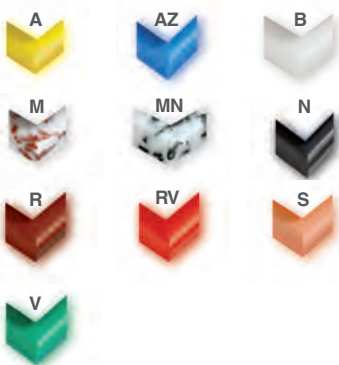

**Tablas de polietileno
Grosor 5 cm**

Polyethylene boards
Thickness 5 cm

Plaques en polyéthylène
Épaisseur 5 cm

Ref.	Medidas Size Dimensions
V-H25195	25 x 19
V-H30205	30 x 20
V-H33195	33 x 19
V-H33335	33 x 33
V-H40205	40 x 20
V-H40255	40 x 25
V-H40305	40 x 30
V-H40335	40 x 33
V-H40405	40 x 40
V-H45455	45 x 45
V-H50255	50 x 25
V-H50305	50 x 30
V-H50335	50 x 33
V-H50405	50 x 40
V-H50505	50 x 50
V-H60255	60 x 25
V-H60305	60 x 30
V-H60335	60 x 33
V-H60405	60 x 40
V-H65455	65 x 45
V-H70505	70 x 50
V-H75255	75 x 25
V-H75335	75 x 33
V-H80405	80 x 40
V-H90455	90 x 45
V-H100255	100 x 25
V-H100335	100 x 33
V-H100505	100 x 50
V-H150255	150 x 25
V-H150335	150 x 33
V-H200255	200 x 25
V-H200335	200 x 33
V-H2001005	200 x 100



**LAS TABLAS REDONDAS Y LAS TABLAS PARA
ACOPLAR SE INCREMENTARÁN 17,00 euros. /
ROUNDS BOARDS AND BOARDS FOR FITTING
INCREASE PRICE IN 17,00 euros. /
PLAQUES RONDES ET PLAQUES POUR AJUSTER
AUGMENTENT PRIX EN 17,00 euros.**

	PRECIO CORTE CM ² EUROS / CUTTING PRICE / PRIX DECOUPE	COLORES / COLOURS / COULEURS
0,3 CM ²	0,0072	B
1 CM ²	0,0156	B
1,5 CM ²	0,0214	B-R-M
2 CM ²	0,0280	B-R-M-A-AZ-S- V-N-RV-MN
3 CM ²	0,0410	B-R-M
4 CM ²	0,0555	B-R-M-A-AZ-S- V-N-RV-MN
5 CM ²	0,0688	B-R-M-A-AZ
9 CM ²	0,1400	B-R
14 CM ²	0,2500	B-R

**LARGO x ANCHO x EUROS CM². EJEMPLO: TABLA
MEDIDA 55x28x3. PRECIO: 55 x 28 x 0,0410 = 63,14 euros.
LENGHT x WIDTH x EUROS CM². EIXAMPLE: BOARD SIZE
55x28x3. PRICE: 55 x 28 x 0,0410 = 63,14 euros.
LONG x LARGE x EUROS CM². EXEMPLE: PLAQUE
DIMENSION 55x28x3. PRIX: 55 x 28 x 0,0410 = 63,14 euros.**

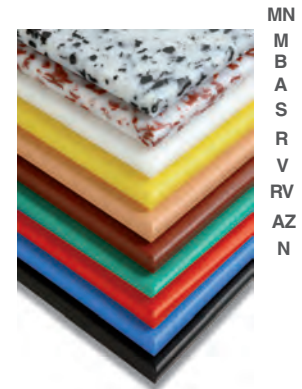

0 1 TABLA POLIETILENO HDPE500 HOSTELERÍA CON GOMAS ANTIDESLIZANTES | HDPE500 HOSPITALITY POLYETHYLENE BOARD WITH NON-SLIP RUBBER | PLATEAU EN POLYÉTHYLÈNE HDPE500 HOSPITALITY AVEC CAOUTCHOUC ANTIDÉRAPANT

Ref.	Medidas Size Dimensions
Y-30201	30 x 20 x 1 cm
Y-40302	40 x 30 x 2 cm
Y-50302	50 x 30 x 2 cm
Y-60402	60 x 40 x 2 cm



B= Blanco / White / Blanc
A= Amarillo / Yellow / Jaune
AZ= Azul / Blue / Bleu
R= Rojo / Red / Rouge
V= Verde / Green / Vert

TABLAS DE POLIETILENO | POLYETHYLENE BOARDS | PLAQUES EN POLYÉTHYLÈNE

**Tablas de polietileno
En Blanco (Ref + B) y Rojo (Ref + R)**

Polyethylene boards
In White (Ref. + B) and Red (Ref. + R)

*Plaques en polyéthylène
Couleurs Blanc (Réf. + B) et Rouge (Réf. + R)*

Ref.	Medidas Size Dimensions
V-H40339	40 x 33 x 9 cm
V-H40409	40 x 40 x 9 cm
V-H45459	45 x 45 x 9 cm
V-H50339	50 x 33 x 9 cm
V-H50509	50 x 50 x 9 cm
V-H60409	60 x 40 x 9 cm
V-H403314	40 x 33 x 14 cm
V-H503314	50 x 33 x 14 cm

**F - Taco madera fabricado en cuadradillo
y 5 cm polietileno rectangulares
En Blanco (Ref + B) y Rojo (Ref + R)**

F - Wooden block and 5 cm rectangular
polyethylene board
In White (Ref. + B) and Red (Ref. + R)

*F - Bloc en bois et plaque en polyéthylène
rectangulaire
Couleurs Blanc (Réf. + B) et Rouge (Réf. + R)*

Ref.	Medida taco Cutting board size Mesure bloc
V-F604020PL	60 x 40 x 20 cm
V-F604025PL	60 x 40 x 25 cm
V-F644520PL	64 x 45 x 20 cm
V-F644525PL	64 x 45 x 25 cm
V-F705020PL	70 x 50 x 20 cm
V-F705025PL	70 x 50 x 25 cm

**Tablas redondo de polietileno
En Blanco (Ref + B) y Rojo (Ref + R)**

Round polyethylene boards
In White (Ref. + B) and Red (Ref. + R)

*Plaques ronds en polyéthylène
Couleurs Blanc (Réf. + B) et Rouge (Réf. + R)*

Ref.	Diámetro Diameter Diamètre	Altura Height Hauteur
V-H355	Ø 35 cm	5 cm
V-H359	Ø 35 cm	9 cm
V-H3514	Ø 35 cm	14 cm
V-H405	Ø 40 cm	5 cm
V-H409	Ø 40 cm	9 cm
V-H4014	Ø 40 cm	14 cm

**F - Taco madera fabricado en cuadradillo
y 5 cm polietileno cuadrados
En Blanco (Ref + B) y Rojo (Ref + R)**

F - Wooden block and 5 cm square
polyethylene board
In White (Ref. + B) and Red (Ref. + R)

*F - Bloc en bois et plaque en polyéthylène
carrée
Couleurs Blanc (Réf. + B) et Rouge (Réf. + R)*

Ref.	Medida taco Cutting board size Mesure bloc
V-F404020PL	40 x 40 x 20 cm
V-F404025PL	40 x 40 x 25 cm
V-F454520PL	45 x 45 x 20 cm
V-F454525PL	45 x 45 x 25 cm
V-F505020PL	50 x 50 x 20 cm
V-F505025PL	50 x 50 x 25 cm

Agujero Ø 12 cm para tabla

Ø 12 cm hole for table

Trou Ø 12 cm pour table

Ref.	Altura Height Hauteur
V-HAGU5	5 cm
V-HAGU9	9 cm
V-HAGU14	14 cm

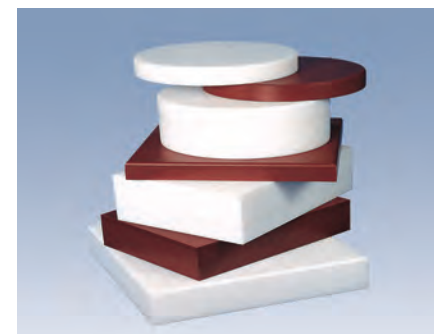



F - Tajo de 4 patas de madera (Ref. A) con taco de madera fabricado en cuadradillo + 5 cm polietileno
Sin portacuchillos. Altura total 85 cm. En Blanco (Ref + B) y Rojo (Ref + R)

F - 4 wooden legs chopping block table (Ref. A) + 5 cm polyethylene board. Without kinve holder. Total height 85 cm. In White (Ref. + B) and Red (Ref. + R)

F - Billot de 4 pieds en bois (Réf. A) + plaque en polyéthylène de 5 cm
Sans porte couteaux. Hauteur totale 85 cm. Couleurs Blanc (Réf. + B) et Rouge (Réf. + R)

Ref.	Medida taco Cutting board size Mesure bloc
V-FA404020PL	40 x 40 x 20 cm
V-FA454520PL	45 x 45 x 20 cm
V-FA505020PL	50 x 50 x 20 cm
V-FA604020PL	60 x 40 x 20 cm
V-FA644520PL	64 x 45 x 20 cm
V-FA705020PL	70 x 50 x 20 cm
V-FA1005020PL	100 x 50 x 20 cm



F - Tajo de 4 patas de acero-inox con faldón (Ref. I) con taco de madera fabricado en cuadradillo + 5 cm polietileno
Sin portacuchillos. Altura total 85 cm. En Blanco (Ref + B) y Rojo (Ref + R)

F - 4 stainless steel legs chopping block table with drawer (Ref. I) + 5 cm polyethylene board. Without kinve holder. Total height 85 cm. In White (Ref. + B) and Red (Ref. + R)

F - Billot de 4 pieds en inox avec jupe (Réf. I) + plaque en polyéthylène de 5 cm
Sans porte couteaux. Hauteur totale 85 cm. Couleurs Blanc (Réf. + B) et Rouge (Réf. + R)

Ref.	Medida taco Cutting board size Mesure bloc
V-FI404020PL	40 x 40 x 20 cm
V-FI454520PL	45 x 45 x 20 cm
V-FI505020PL	50 x 50 x 20 cm
V-FI604020PL	60 x 40 x 20 cm
V-FI644520PL	64 x 45 x 20 cm
V-FI705020PL	70 x 50 x 20 cm
V-FI1005020PL	100 x 50 x 20 cm



F - Tajo de 4 patas de acero-inox sin faldón (Ref. I-2) con taco de madera fabricado en cuadradillo + 5 cm polietileno
Sin portacuchillos. Altura total 85 cm. En Blanco (Ref + B) y Rojo (Ref + R)

F - 4 stainless steel legs chopping block table without drawer (Ref. I-2) + 5 cm polyethylene board. Without kinve holder. Total height 85 cm. In White (Ref. + B) and Red (Ref. + R)

F - Billot de 4 pieds en inox sans jupe (Réf. I-2) + plaque en polyéthylène de 5 cm
Sans porte couteaux. Hauteur totale 85 cm. Couleurs Blanc (Réf. + B) et Rouge (Réf. + R)

Ref.	Medida taco Cutting board size Mesure bloc
V-FI2404020PL	40 x 40 x 20 cm
V-FI2454520PL	45 x 45 x 20 cm
V-FI2505020PL	50 x 50 x 20 cm
V-FI2604020PL	60 x 40 x 20 cm
V-FI2644520PL	64 x 45 x 20 cm
V-FI2705020PL	70 x 50 x 20 cm
V-FI21005020PL	100 x 50 x 20 cm

0 1 TAJO DE 4 PATAS CON TACO MADERA Y SOBRE DE POLIETILENO | 4 LEGS WOODEN CHOPPING BLOCK WITH POLYETHYLENE BOARD | *BILLOT EN BOIS DE 4 PIEDS AVEC PLAQUE EN POLYÉTHYLÈNE*



F - Tajo de 4 patas insonorizado de acero-inox (Ref. S) con taco de madera fabricado en cuadradillo + 5 cm polietileno Sin portacuchillo. Altura total 85 cm. En Blanco (Ref + B) y Rojo (Ref + R)

F - 4-leg stainless steel sound proof anti-vibration chopping block table (Ref. S) + 5 cm polyethylene board Without knife holder. Total height 85 cm. In White (Ref. + B) and Red (Ref. + R)

F - Billot avec 4 pieds acier inox insonorisé antivibratoire (Réf. S) + plaque en polyéthylène de 5 cm Sans porte couteaux. Hauteur totale 85 cm. Couleurs Blanc (Réf. + B) et Rouge (Réf. + R)

Ref.	Medida taco Cutting board size Mesure bloc
V-FS454520PL	45 x 45 x 20 cm
V-FS604020PL	60 x 40 x 20 cm
V-FS705020PL	70 x 50 x 20 cm

MESAS DE CORTE | CUTTING TABLES | *TABLES DÉCOUPE*



L-2 - Mesa de madera sin faldón y sobre de polietileno Polietileno 5 cm, altura total 90 cm En Blanco (Ref + B) y Rojo (Ref + R)

L-2 - Wooden table without drawer and polyethylene board Polyethylene 5 cm, total Height 90 cm. In White (Ref. + B) and Red (Ref. + R)

L-2 - Table en bois de découpe sans jupe et plaque en polyéthylène Polyéthylène 5 cm, hauteur Totale 90 cm. Couleurs Blanc (Réf. + B) et Rouge (Réf. + R)

Ref.	Medidas Size Dimensions
V-L240405	40 x 40 cm
V-L245455	45 x 45 cm
V-L250505	50 x 50 cm
V-L260405	60 x 40 cm
V-L270505	70 x 50 cm

Mesa de madera sin faldón y sobre de polietileno Polietileno 9 cm, altura total 94 cm En Blanco (Ref + B) y Rojo (Ref + R)

Wooden table without drawer and polyethylene board Polyethylene 9 cm, total Height 94 cm. In White (Ref. + B) and Red (Ref. + R)

Table en bois de découpe sans jupe et plaque en polyéthylène Polyéthylène 9 cm, hauteur Totale 94 cm. Couleurs Blanc (Réf. + B) et Rouge (Réf. + R)

Ref.	Medidas Size Dimensions
V-L240409	40 x 40 cm
V-L245459	45 x 45 cm
V-L250509	50 x 50 cm
V-L260409	60 x 40 cm
V-L270509	70 x 50 cm



K - Mesa de acero-inox con faldón y estante sobre de polietileno
Polietileno 5 cm, altura total 90 cm
En Blanco (Ref + B) y Rojo (Ref + R)

K - Stainless steel table with drawer and shelf + polyethylene
 Polyethylene 5 cm, total height 90 cm.
 In White (Ref. + B) and Red (Ref. + R)

K - Table d'inox avec jupe et étagère + polyéthylène
Polyéthylène 5 cm, hauteur totale 90 cm.
Couleurs Blanc (Réf. + B) et Rouge (Réf. + R)

Ref.	Medidas Size Dimensions
V-K40405	40 x 40 cm
V-K45455	45 x 45 cm
V-K50505	50 x 50 cm
V-K60405	60 x 40 cm
V-K70505	70 x 50 cm

Mesa de acero-inox con faldón y estante sobre de polietileno
Polietileno 9 cm, altura total 94 cm
En Blanco (Ref + B) y Rojo (Ref + R)

Stainless steel table with drawer and shelf + polyethylene
 Polyethylene 9 cm, total Height 94 cm.
 In White (Ref. + B) and Red (Ref. + R)

Table d'inox avec jupe et étagère + polyéthylène
Polyéthylène 9 cm, hauteur Totale 94 cm.
Couleurs Blanc (Réf. + B) et Rouge (Réf. + R)

Ref.	Medidas Size Dimensions
V-K40409	40 x 40 cm
V-K45459	45 x 45 cm
V-K50509	50 x 50 cm
V-K60409	60 x 40 cm
V-K70509	70 x 50 cm



K-5 - Mesa de acero-inox pesada con faldón y estante sobre de polietileno
Polietileno 5 cm, altura total 90 cm
En Blanco (Ref + B) y Rojo (Ref + R)

K-5 - Stainless steel heavy table with drawer and shelf + polyethylene
 Polyethylene 5 cm, total height 90 cm.
 In White (Ref. + B) and Red (Ref. + R)

K-5 - Table lourd d'inox avec jupe et étagère + polyéthylène
Polyéthylène 5 cm, hauteur totale 90 cm.
Couleurs Blanc (Réf. + B) et Rouge (Réf. + R)

Ref.	Medidas Size Dimensions
V-K540405	40 x 40 cm
V-K545455	45 x 45 cm
V-K550505	50 x 50 cm
V-K560405	60 x 40 cm
V-K570505	70 x 50 cm

Mesa de acero-inox pesada con faldón y estante sobre de polietileno
Polietileno 9 cm, altura total 94 cm
En Blanco (Ref + B) y Rojo (Ref + R)

Stainless steel heavy table with drawer and shelf + polyethylene
 Polyethylene 9 cm, total Height 94 cm.
 In White (Ref. + B) and Red (Ref. + R)

Table lourd d'inox avec jupe et étagère + polyéthylène
Polyéthylène 9 cm, hauteur Totale 94 cm.
Couleurs Blanc (Réf. + B) et Rouge (Réf. + R)

Ref.	Medidas Size Dimensions
V-K540409	40 x 40 cm
V-K545459	45 x 45 cm
V-K550509	50 x 50 cm
V-K560409	60 x 40 cm
V-K570509	70 x 50 cm



MI - Mesa total de acero-inox desmontable con estante
Altura total 85 cm.

MI - Total stainless steel detachable table with shelf
 Total height 85 cm.

MI - Table totale d'inox démontable avec étagère
 Hauteur totale 85 cm.

Ref.	Medidas Size Dimensions
V-MI10060C	100 x 60 cm
V-MI10070C	100 x 70 cm
V-MI15060C	150 x 60 cm
V-MI15070C	150 x 70 cm
V-MI20060C	200 x 60 cm
V-MI20070C	200 x 70 cm

MI - Mesa total de acero-inox desmontable sin estante
Altura total 85 cm.

MI - Total stainless steel detachable table without shelf
 Total height 85 cm.

MI - Table totale d'inox démontable sans étagère
 Hauteur totale 85 cm.

Ref.	Medidas Size Dimensions
V-MI10060S	100 x 60 cm
V-MI10070S	100 x 70 cm
V-MI15060S	150 x 60 cm
V-MI15070S	150 x 70 cm
V-MI20060S	200 x 60 cm
V-MI20070S	200 x 70 cm



Mesa acero-inox para cortadoras 2 estantes

Stainless steel table for cutters
 2 shelves

Table inox pour cutters 2
 étagères

Ref.	Medidas Size Dimensions
V-MI7050	70 x 50 x 85 cm



Mesa acero-inox para sierra 1 estante

Stainless steel table for saw 1
 shelf

Table inox pour scie 1 étagère

Ref.	Medidas Size Dimensions
V-MI5050	50 x 50 x 65 cm

Soporte mostrador acero-inox, 2 patas con guías regulables
Altura mínima 80, máxima 88 cm.

Stainless steel counter support,
 2 legs with fittable guides
 Minimum height 80, maximum
 88 cm.

Support comptoir inox, 2 pattes
 avec guides réglables
 Hauteur minimum 80, maximum
 88 cm.

Ref.	Medidas Size Dimensions
V-MIS	69 x 49 cm



MM - Mesa de acero-inox con sobre mixto con estante
Con banda de 30 cm de polietileno de 2 cm grosor. Altura total 85 cm. En blanco (X=B) ó rojo (X=R).

MM - Stainless steel table with mixed top and shelf
 With 30 cm polyethylene board of 2 cm thickness. Total height 85 cm.
 In white (X=B) or red (X=R).

MM - Table acier inox avec surface mixte et étagère
 Table de 30 cm en poléthylène de 2 cm d'épaisseur. Hauteur totale
 85 cm. En blanc (X=B) ou rouge (X=R).

MM - Mesa de acero-inox con sobre mixto sin estante
Con banda de 30 cm de polietileno de 2 cm grosor. Altura total 85 cm. En blanco (X=B) ó rojo (X=R).

MM - Stainless steel table with mixed top and without shelf
 With 30 cm polyethylene board of 2 cm thickness. Total height 85 cm.
 In white (X=B) or red (X=R).

MM - Table acier inox avec surface mixte et sans étagère
 Table de 30 cm en poléthylène de 2 cm d'épaisseur. Hauteur totale
 85 cm. En blanc (X=B) ou rouge (X=R).

Ref.	Medidas Size Dimensions
V-MM10060XS	100 x 60 cm
V-MM10070XS	100 x 70 cm
V-MM15060XS	150 x 60 cm
V-MM15070XS	150 x 70 cm
V-MM20060XS	200 x 60 cm
V-MM20070XS	200 x 70 cm

Ref.	Medidas Size Dimensions
V-MM10060XC	100 x 60 cm
V-MM10070XC	100 x 70 cm
V-MM15060XC	150 x 60 cm
V-MM15070XC	150 x 70 cm
V-MM20060XC	200 x 60 cm
V-MM20070XC	200 x 70 cm



MP - Mesa acero-inox con sobre total de polietileno sin estante
Con Sobre total de polietileno de 2 cm de grosor. Altura total 87 cm. En blanco (X=B) ó rojo (X=R).

MP - Stainless steel table with total polyethylene top without shelf
 Polyethylene top of 2 cm thickness. Total height 87 cm. In white
 (X=B) or red (X=R).

MP - Table acier inox avec surface en poléthylène sans étagère
 Polyéthylène de 2 cm d'épaisseur. Hauteur totale 87 cm. En blanc
 (X=B) ou rouge (X=R).

MP - Mesa acero-inox con sobre total de polietileno con estante
Con Sobre total de polietileno de 2 cm de grosor. Altura total 87 cm. En blanco (X=B) ó rojo (X=R).

MP - Stainless steel table with total polyethylene top with shelf
 Polyethylene top of 2 cm thickness. Total height 87 cm. In white
 (X=B) or red (X=R).

MP - Table acier inox avec surface en poléthylène avec étagère
 Polyéthylène de 2 cm d'épaisseur. Hauteur totale 87 cm. En blanc
 (X=B) ou rouge (X=R).

Ref.	Medidas Size Dimensions
V-MP10060XC	100 x 60 cm
V-MP10070XC	100 x 70 cm
V-MP15060XC	150 x 60 cm
V-MP15070XC	150 x 70 cm
V-MP20060XC	200 x 60 cm
V-MP20070XC	200 x 70 cm

Ref.	Medidas Size Dimensions
V-MP10060XS	100 x 60 cm
V-MP10070XS	100 x 70 cm
V-MP15060XS	150 x 60 cm
V-MP15070XS	150 x 70 cm
V-MP20060XS	200 x 60 cm
V-MP20070XS	200 x 70 cm



MX - Mesa de acero-inox económica con sobre total de polietileno con estante
Con sobre total de polietileno de 2 cm de grosor. Altura total 85 cm. En blanco (X=B) ó rojo (X=R).

MX - Stainless steel economic table with total polyethylene top and shelf
 Total polyethylene top de 2 cm thickness. Total height 85 cm. In white (X=B) or red (X=R).

MX - Table acier inox économique avec surface en polyéthylène avec étagère
 Surface en polyéthylène de 2 cm d'épaisseur. Hauteur totale 85 cm. En blanc (X=B) ou rouge (X=R).

Ref.	Medidas Size Dimensions
V-MX10050XC	100 x 50 cm
V-MX10060XC	100 x 60 cm
V-MX10070XC	100 x 70 cm
V-MX15050XC	150 x 50 cm
V-MX15060XC	150 x 60 cm
V-MX15070XC	150 x 70 cm
V-MX20050XC	200 x 50 cm
V-MX20060XC	200 x 60 cm
V-MX20070XC	200 x 70 cm

MX - Mesa de acero-inox económica con sobre total de polietileno sin estante
Con sobre total de polietileno de 2 cm de grosor. Altura total 85 cm. En blanco (X=B) ó rojo (X=R).

MX - Stainless steel economic table with total polyethylene top and without shelf
 Total polyethylene top de 2 cm thickness. Total height 85 cm. In white (X=B) or red (X=R).

MX - Table acier inox économique avec surface en polyéthylène avec sans étagère
 Surface en polyéthylène de 2 cm d'épaisseur. Hauteur totale 85 cm. En blanc (X=B) ou rouge (X=R).

Ref.	Medidas Size Dimensions
V-MX10050XS	100 x 50 cm
V-MX10060XS	100 x 60 cm
V-MX10070XS	100 x 70 cm
V-MX15050XS	150 x 50 cm
V-MX15060XS	150 x 60 cm
V-MX15070XS	150 x 70 cm
V-MX20050XS	200 x 50 cm
V-MX20060XS	200 x 60 cm
V-MX20070XS	200 x 70 cm

ARTÍCULOS MESA POLIETILENO PE 500 | POLYETHYLENE TABLE ARTICLES | ACCESOIRES DE CUISINE EN POLYÉTHYLÈNE



Tabla canal recoge-jugos
En Blanco (Ref + B) y Rojo (Ref + R)

Cutting board with juice canal
 In White (Ref. + B) and Red (Ref. + R)

Planche avec canal pour garder le jus
 Couleurs Blanc (Réf. + B) et Rouge (Réf. + R)

Ref.	Medidas Size Dimensions
V-HC3320	33 x 20 x 1,5
V-HC5020	50 x 20 x 1,5
V-HC10020	100 x 20 x 1,5

Plato pulpo

Octopus plate

Assiette poulpe

Ref.	Diámetro Diameter Diamètre	Altura Height Hauteur
A-48-18	Ø 18 cm	2 cm
A-48-22	Ø 22 cm	2 cm
A-48-26	Ø 26 cm	2 cm



Tabla ranuras pan, salmón

Bread utting board, salmon

Planche pour couper le pain, saumon

Ref.	Medidas Size Dimensions
V-HRP-40302S	40 x 30 x 2 cm



Mano para colador chino

Handle for placing cone strainer 45 cm

Triangle pour passoire chinois 45 cm

Ref.

A-42

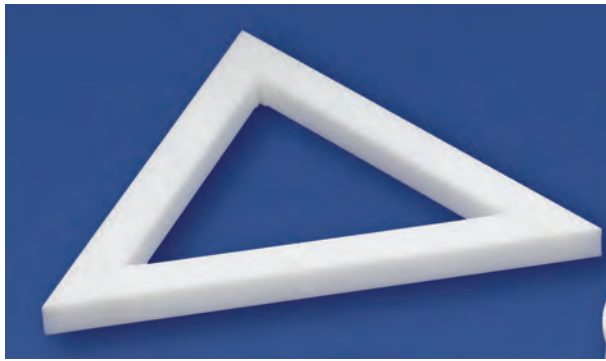

Triángulo para colador chino 45 cm

Triangle for placing cone strainer 45 cm

Triangle pour passoire chinois 45 cm

Ref.

A-41



Mortero sin mano

Mortar

Mortier

Ref.	Diámetro Diameter Diamètre
A-43	Ø 18 cm
A-43-P	Ø 14 cm



Mano mortero A-43

Pestle for A-43

Pilon pour mortier A-43

Ref.	Medidas Size Dimensions
A-44	20 x 5 cm
A-44-P	18,5 x 4,5 cm

Rodillo amasador

Dough roller

Rouleau à pâtisserie

Ref.	Diámetro Diameter Diamètre	Largo Long Longueur
A-46	Ø 5 cm	50 cm
A-47	Ø 6 cm	60 cm





Maza para picar hielo Polietileno + Inox.

Mace ice crushing Polietileno + Inox.

Glace pilée maza Polietileno + Inox.

Ref.	Medidas Size Dimensions
A-57	6 x 6 x 10 cm

PALAS POLIETILENO | POLYETHYLENE SLICES | PALLES EN POLYÉTHYLÈNE

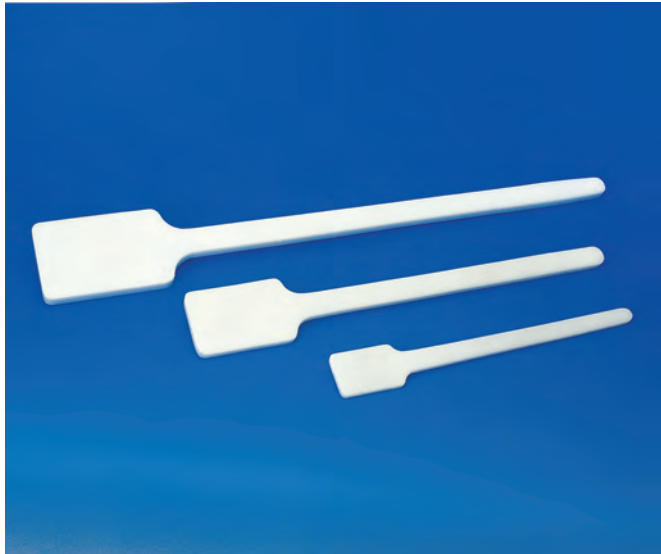

Pala polietileno

Polyethylene slice

Palle en polyéthylène

Ref.	Largo Long Longueur
A-30-50	50 cm
A-30-70	70 cm
A-30-100	100 cm



Pala polietileno + inox

Polyethylene slice + stainless steel

Palle en polyéthylène + inox

Ref.	Largo Long Longueur
A-30-50-I	50 cm
A-30-70-I	70 cm
A-30-100-I	100 cm

SOPORTE TABLAS POLIETILENO | POLYETHYLENE BOARDS STAND | SUPPORT PLAQUES POLIÉTHYLÈNE



Soporte tabla polietileno acero-inox (máx. grueso 3 cm)

Stainless steel polyethylene board support

Support plaque polyéthylène acier inox

Ref.
SPI-6



Soporte polietileno

Polyethylene stand

Support polyéthylène

Ref.	Medidas Size Dimensions	Color Colour Couleur
V-SP2B	27 x 19 x 3 cm	○
V-SP2R	27 x 19 x 3 cm	●

Soporte polietileno marmóreo

Marble imitation polyethylene stand

Support polyéthylène marbre

Ref.	Medidas Size Dimensions
V-SP2M	27 x 19 x 3 cm



**Tabla corte con cubeta
Con guías para cubeta gastronorm GI-1/2-65. Altura 10 cm**

Cuvette cutting board
With gastronorm tray guides GI-1 / 2-65.
Height 10 cm

Planche à découper cuvette
Avec guides de plateaux gastronorm GI-1 / 2-65. Hauteur 10 cm

Ref.	Medidas Size Dimensions
V-HG40302V	40 x 30 x 2 cm



**Tabla madera presentación
Con dos listones inferiores**

Wood presentation table
With two lower slats

Table de présentation en bois
Avec deux lattes inférieures

Ref.	Medidas Size Dimensions
V-TP30202	30 x 20 x 2 cm
V-TP35252	35 x 25 x 2 cm



**Mesa cocina madera
Con dos estantes y cuatro ruedas
giratorias con freno. Altura 90 cm**

Wood kitchen table
With two shelves and four rotating wheels
with brake. Height 90 cm

Table de cuisine en bois
Avec deux étagères et quatre roues en
rotation avec frein. Hauteur 90 cm

Ref.	Medidas Size Dimensions
V-MC60505-R	60 x 50 x 5 cm

**Mesa cocina madera
Con dos estantes. Altura 90 cm**

Wood kitchen table
With two shelves. Height 90 cm

Table de cuisine en bois
Avec deux étagères. Hauteur 90 cm

Ref.	Medidas Size Dimensions
V-MC60505	60 x 50 x 5 cm



0

2

**Carteles portaprecios, Peana - Plataformas -
Pinzas, Listas de precios, Carteles señalización,
Guirnaldas, Separadores, Barreños, Base
rodante, Cubetas, Bandejas, Gastronorm,
PlexiLine.**

Price tag holder, Stand - platforms - Clips, Price
lists, Sign, Garlands, Separators, Tubs, Rolling
base, Containers, Trays, Gastronorm, PlexiLine.

*Affiches porte prix, Socle - plate-formes - clips,
Liste prix, Affiches signalization, Guirlandes,
Séparateurs, Bassines, Base roulante, Bacs,
Plateaux, Gastronorm, PlexiLine.*

21 - 62



Porcino, num. relieve, con base

Pork, num. relief, with base

Porcin, num. relief, avec base

Ref.	Medidas Size Dimensions	Unidades Units Unités
C-300	8,5 x 6,5	12



Ternera, num. relieve, con base

Veal, num. relief, with base

Veau, num. relief, avec base

Ref.	Medidas Size Dimensions	Unidades Units Unités
C-301	8,5 x 6,5	12



Cordero, num. relieve, con base

Lamb, num. relief, with, base

Agneau, num. relief, avec base

Ref.	Medidas Size Dimensions	Unidades Units Unités
C-302	8,5 x 6,5	12



Pollo, num. relieve, con base

Chicken, num. relief, with base

Poulet, num. relief, avec base

Ref.	Medidas Size Dimensions	Unidades Units Unités
C-303	8,5 x 6,5	12



Charcutería, num. relieve, con base

Charcuterie, num. relief, with base

Charcuterie, num. relief, avec base

Ref.	Medidas Size Dimensions	Unidades Units Unités
C-304	8,5 x 6,5	12



Quesos, num. relieve, con base

Cheeses, num. relief, with base

Fromages, num. relief, avec base

Ref.	Medidas Size Dimensions	Unidades Units Unités
C-305	8,5 x 6,5	12



Liso Pizarra

Plane board

Tableau lisse

Ref.	Medidas Size Dimensions	Unidades Units Unités
C-307	8,5 x 6,5 cm	12



Panadería/Pastelería, num. relieve, con base

Bakery/Pastry, num. relief, with base

Boulangerie/Pâtisserie, num. relief, avec base

Ref.	Medidas Size Dimensions	Unidades Units Unités
C-306	8,5 x 6,5	12



Porcino, num. relieve, con base

Pork, num. relief, with base

Porcin, num. relief, avec base

Ref.	Medidas Size Dimensions	Unidades Units Unités
C-310	10,5 x 7,5	12



Ternera, num. relieve, con base

Veal, num. relief, with base

Veau, num. relief, avec base

Ref.	Medidas Size Dimensions	Unidades Units Unités
C-311	10,5 x 7,5	12



Cordero, num. relieve, con base

Lamb, num. relief, with base

Agneau, num. relief, avec base

Ref.	Medidas Size Dimensions	Unidades Units Unités
C-312	10,5 x 7,5	12



Pollo, num. relieve, con base

Chicken, num. relief, with base

Poulet, num. relief, avec base

Ref.	Medidas Size Dimensions	Unidades Units Unités
C-313	10,5 x 7,5	12



Charcutería, num. relieve, con base

Charcutería, num. relieve, with base

Charcuterie, num. relief, avec, base

Ref.	Medidas Size Dimensions	Unidades Units Unités
C-314	10,5 x 7,5	12



Quesos, num. relieve, con base

Cheeses, num. relief, with base

Fromages, num. relief, avec base

Ref.	Medidas Size Dimensions	Unidades Units Unités
C-315	10,5 x 7,5	12



Liso pizarra

Plane board

Tableau lisse

Ref.	Medidas Size Dimensions	Unidades Units Unités
C-317	10,5 x 7,5 cm	12



Frutas, nº relieve, con ganchos

Fruits, num. relief, with hooks

Fruits, num. relief, avec crochets

Ref.	Medidas Size Dimensions	Unidades Units Unités
C-320	13 x 9,5	12

0 2 CARTELES PORTAPRECIOS RUEDAS | ROTATING PRICE TAG HOLDERS | AFFICHES PORTE PRIX ROULETTES

Material Glaspar, con pincho acero-inoxidable, arandela de plástico y remaches de plástico

Made on Glaspar material, spike of Stainless Steel, plastic round base and Plastic rivets

Matériel Glaspar, pique en acier Inox, rondelle plastique et rivets plastiques



Nº ruedas, fondo rojo

Num. rotating, red deep

Num. roulette, fond rouge

Ref.	Medidas Size Dimensions	Unidades Units Unités
C-10	8 x 7	12



Nº ruedas 8x7 fondo azul

Num rotating 8x7 cm blue deep

Num. roulettes 8x7 cm fond bleu

Ref.	Medidas Size Dimensions	Unidades Units Unités
C-10-AZ	8 x 7	12



Nº ruedas, fondo blanco

Num. rotating, white deep

Num. roulettes, fond blanc

Ref.	Medidas Size Dimensions	Unidades Units Unités
C-10-B	8 x 7	12



Nº ruedas 10x7,5 cm. fondo rojo

Num. rotating 10x7,5 cm. red deep

Num. roulettes 10x7,5 fond rouge

Ref.	Medidas Size Dimensions	Unidades Units Unités
C-11	10 x 7,5	12



Nº ruedas, fondo azul

Num. rotating, blue deep

Num. roulettes, fond bleu

Ref.	Medidas Size Dimensions	Unidades Units Unités
C-11-AZ	10 x 7,5	12



Nº ruedas, fondo blanco

Num. rotating, white deep

Num. roulettes, fond blanc

Ref.	Medidas Size Dimensions	Unidades Units Unités
C-11-B	10 x 7,5	12



Nº ruedas, rojo, con rueda para indicar kg-unidades-100gr. - 1/4

Num. rotating, red, wheel for kilo-unit - 100 gr. - 1/4

Nº roulettes, rouge, roulette pour kilo-unité, 100 gr. - 1/4

Ref.	Medidas Size Dimensions	Unidades Units Unités
C-65-R	11 x 7,5	12



Nº ruedas, azul, con rueda para indicar kilo-unid. -100 gr., 1/4

Num. rotating, blue, wheel for kilo-unit - 100 gr. - 1/4

Nº roulettes, pré, roulette pour kilo-unité - 100 gr. - 1/4

Ref.	Medidas Size Dimensions	Unidades Units Unités
C-65-AZ	11 x 7,5	12



Nº ruedas, verde, con rueda para indicar kilo-unidad - 100 gr. - 1/4

Num. rotating, green, wheel for kilo-unit-100 gr. - 1/4

Num. roulettes, vert, roulette pour kilo-unité-100 gr. - 1/4

Ref.	Medidas Size Dimensions	Unidades Units Unités
C-65-V	11 x 7,5	12



Nº ruedas, blanco, con rueda para indicar kilo-unid.- 100 gr. - 1/4

Num. rotating, white, wheel for kilo-unit - 100 gr. - 1/4

Num. roulettes, white, roulette pour kilo-unité - 100 gr. - 1/4

Ref.	Medidas Size Dimensions	Unidades Units Unités
C-65-B	11 x 7,5	12



Nº ruedas, naranja

Num. rotating orange

Num. roulettes fond rouge orange

Ref.	Medidas Size Dimensions	Unidades Units Unités
C-15-N	13 x 10 v	12



Nº ruedas

Num. rotating

Nº roulettes

Ref.	Medidas Size Dimensions	Unidades Units Unités
C-17	11 x 7,5	12



Nº ruedas - Pescadero normativa

Num. rotating - Fish regulations

Num. roulettes - Poisson regulations

Ref.	Medidas Size Dimensions	Unidades Units Unités
C-24	13 x 9	12



Nº ruedas - Pescadero normativa - Con base

Num. rotating - Fish regulations

Num. roulettes - Poisson regulations

Ref.	Medidas Size Dimensions	Unidades Units Unités
C-24-B	12 x 8	12



Nº ruedas - Pescadero normativa - Portatarjeta

Num. rotating - Fish regulations

Nº roulettes - Poisson regulations

Ref.	Medidas Size Dimensions	Unidades Units Unités
C-24-T	12 x 8	12



Pescadería, nº relieve, con base

Fish, num.relief, with base

Poisson, num. relief, avc base

Ref.	Medidas Size Dimensions	Unidades Units Unités
C-321	13 x 9,5 cm	12



Nº ruedas, prado, Rueda para indicar kilo-unid. - 100 gr. - 1/4

Num. rotating, Meadow, with wheel for kilo-unit-100 gr - 1/4

Num roulettes, Pré, roulette pour kilo-unité-100 gr. - 1/4

Ref.	Medidas Size Dimensions	Unidades Units Unités
C-38	11 x 7,5	12



Nº ruedas, pergamino, con rueda para indicar kilo-unidad - 100 gr. - 1/4

Num. rotating, scroll, with wheel for kilo-unit - 100gr. - 1/4

Num. roulettes, parchemin, roulette pour kilo-unité - 100 gr. - 1/4

Ref.	Medidas Size Dimensions	Unidades Units Unités
C-66	11 x 7,5	12



Nº ruedas, pergamino

Num. rotating, scroll

Num. roulettes, fond rouge parchemin

Ref.	Medidas Size Dimensions	Unidades Units Unités
C-13	13 x 10	12



Nº ruedas, 3+2 dígitos fondo blanco

Num. rotating, 3+2 digits white deep

Num. roulette, 3+2 chiffres - fond blanc

Ref.	Medidas Size Dimensions	Unidades Units Unités
C-90-B	13 x 8	12



Nº ruedas, 3+2 dígitos fondo azul

Num. rotating, 3+2 digits blue deep

Num. roulette, 3+2 chiffres - fond bleu

Ref.	Medidas Size Dimensions	Unidades Units Unités
C-90-AZ	13 x 8	12



Nº ruedas, 3+2 dígitos fondo rojo

Num. rotating, 3+2 digits red deep

Num. roulette, 3+2 chiffres - fond rouge

Ref.	Medidas Size Dimensions	Unidades Units Unités
C-90-R	13 x 8	12

CARTELES PORTAPRECIOS BASE | BASE PRICE TAG HOLDER | AFFICHES PORTE PRIX BASE

Material Glaspar, con pincho acero-inoxidable, arandela de plástico y remaches de plástico

Made on Glaspar material, spike of stainless steel, plastic round base and plastic rivets

Matériel Glaspar, pique en acier inox, rondelle plastique et rivets plastiques

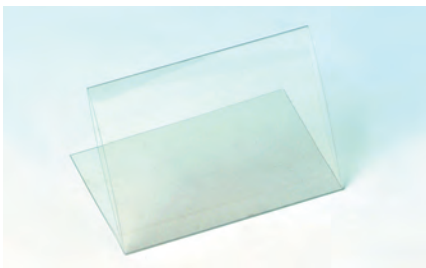

Porta tarjeta transparente con base

Transparent card holder with base

Porte-carte transparent avec base

Ref.	Medidas Size Dimensions	Unidades Units Unités
C-132	9,5 x 7	12

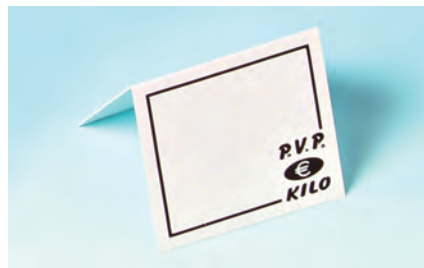

Cartel doble cara liso

Two-faced tag plane

Affiche de double face lisse

Ref.	Medidas Size Dimensions	Unidades Units Unités
C-140	7 x 6	12



Cartel doble cara liso

Two-faced tag plane

Affiche de double face lisse

Ref.	Medidas Size Dimensions	Unidades Units Unités
C-141	12 x 8	12



Nº ruedas, azul con rueda para indicar kilo-unid. - 100 gr. - 1/4, con base

Num. rotating, blue, with wheel for kilo-unit-100 gr.-1/4, with base

Num. roulettes, bleu, avec roulette pour kilo-unit-100 gr.-1/4, avec base

Ref.	Medidas Size Dimensions	Unidades Units Unités
C-65-AZB	11 x 7,5	9



Nº ruedas, rojo con rueda para indicar kilo-unid. - 100 gr. - 1/4

Num. rotating, red, with wheel for kilo-unit - 100 gr. - 1/4

Num. roulettes, rouge, avec roulette pour kilo-unité - 100 gr. - 1/4

Ref.	Medidas Size Dimensions	Unidades Units Unités
C-65-RB	11 x 7,5	12



Nº ruedas verde, con rueda para indicar Kg-unid.-100 gr.-1/4, con base

Num. rotating, green, 11x7,5 cm., con rueda para indicar Kg.-unid.-100 gr.-1/4, with base

Num. roulettes, vert, avec roulette pour Kg.-unit-100 gr.-1/4, avec base

Ref.	Medidas Size Dimensions	Unidades Units Unités
C-65-VB	11 x 7,5	12



Nº ruedas, blanco, con rueda para indicar kilo-unid.- 100 gr. - 1/4

Num. rotating, white, 11x7,5 cm., wheel for kilo-unit - 100 gr. - 1/4

Num. roulettes, white, 11x7,5 cm., roulette pour kilo-unité - 100 gr. - 1/4

Ref.	Medidas Size Dimensions	Unidades Units Unités
C-65-BB	11 x 7,5	12



Nº ruedas, pergamino, con rueda para indicar Kg-unid.-100 gr.-1/4, con base

Num. rotating, scroll, with wheel for kilo-unit-100 gr.- 1/4, with base

Num. roulettes, parchemin, avec roulette pour kilo-unité-100 gr.-1/4, avec base

Ref.	Medidas Size Dimensions	Unidades Units Unités
C-66-B	11 x 7,5	12



Nº ruedas, con plataforma panadería-pastelería

Num. rotating, bakery

Num. roulettes, boulangerie

Ref.	Medidas Size Dimensions	Unidades Units Unités
C-67	8,5 x 6,5	12



Nº ruedas, con plataforma, azul

Num. rotating, with base, blue

Num. roulettes, avec base, bleu

Ref.	Medidas Size Dimensions	Unidades Units Unités
C-67-AZ	8,5 x 6,5	12



Nº ruedas, con plataforma, rojo

Num. rotating, red, with base

Num. roulettees, rouge, avec base

Ref.	Medidas Size Dimensions	Unidades Units Unités
C-67-R	8,5 x 6,5	12



Nº ruedas, prado con rueda para indicar Kg-unid. - 100 gr. - 1/4, con base

Num. rotating, meadow, kilo-unit-100 gr. - 1/4, with base

Num. roulettes, pré, kilo-unité-100 gr.- 1/4, avec base

Ref.	Medidas Size Dimensions	Unidades Units Unités
C-38-B	11 x 7,5	12



Liso con base

Plane with base

Lisse avec base

Ref.	Medidas Size Dimensions	Unidades Units Unités
C-7-B	10 x 7	12

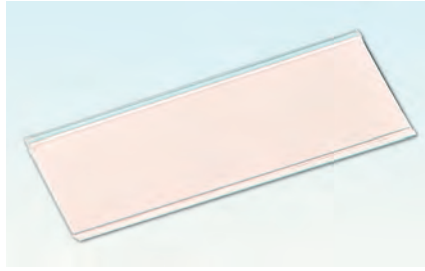

Guía adhesiva para etiquetas, transparente

Transparent adhesive label holder

Tringle adhésive transparent pour étiquettes

Ref.	Medidas Size Dimensions	Unidades Units Unités
C-130	10 x 4	12

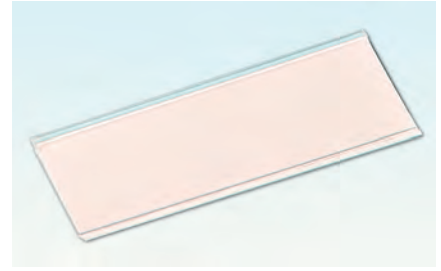

Guía adhesiva para etiquetas, 100x4 cm, transparente

Transparent adhesive label holder, 100x4 cm

Tringle adhésive transparent pour étiquettes, 100x4 cm

Ref.	Medidas Size Dimensions	Unidades Units Unités
C-131		

CARTELES PORTAPRECIOS LISOS-DIGITAL | SMOOTH LABELED DIGITAL PRICE TAG HOLDERS | AFFICHES PORTE PRIX LISSE-DIGITAL

Material: Glaspar, Pincho: Acero-inox, Arandela: Plástico, Remaches:Plástico

Material: Glaspar, Spike: Stainless Steel, Round base: Plastic, Rivets: Plastic

Matériel: Glaspar, Pique: Acier inox, Rondelle: Plastique, Rivets: Plastique



Nº digital fondo azul

Num. digital blue deep

Num. digital fond bleu

Ref.	Medidas Size Dimensions	Unidades Units Unités
C-91	11 x 8	12



Nº digital fondo rojo

Num. digital red deep

Num. digital fond bleu

Ref.	Medidas Size Dimensions	Unidades Units Unités
C-92	11 x 8	12



Liso pizarra con pincho

Smooth slate with skewerSmooth slate with skewer

Ardoise lisse avec pin

Ref.	Medidas Size Dimensions	Unidades Units Unités
C-97	8,5 x 6,5 cm	12

C-98	15,5 x 9 cm	12
------	-------------	----



Liso pizarra sin pincho

Smooth slate with skewerSmooth slate without skewer

Ardoise lisse sans pin

Ref.	Medidas Size Dimensions	Unidades Units Unités
C-97-N	8,5 x 6,5 cm	12

C-98-N	15,5 x 9 cm	12
--------	-------------	----



Dorado rectangular

Golden rectangular

Rectangulaire dorée

Ref.	Medidas Size Dimensions	Unidades Units Unités
C-81	6 x 4	12



Dorado oval

Golden oval

Ovale doré

Ref.	Medidas Size Dimensions	Unidades Units Unités
C-82	5 x 4	12



Visera oferta para carteles ruedas

Offer top for rotating tags

Visière d'offre pour affiches roulettes

Ref.	Medidas Size Dimensions	Unidades Units Unités
C-2		12



Nº digital fondo dorado

Num. digital golden deep

Num. digital fond doré

Ref.	Medidas Size Dimensions	Unidades Units Unités
C-99	11 x 8	12

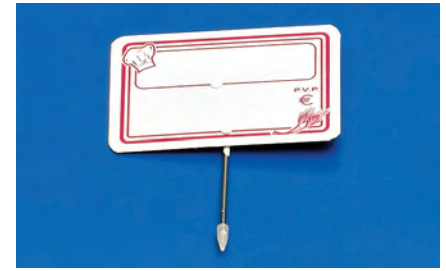

Liso Panadería-Pastelería

Plane bakery/Pâtisserie

Lisse Boulangerie/Pâtisserie

Ref.	Medidas Size Dimensions	Unidades Units Unités
C-39	8,5 x 6	12



Liso

Plane

Lisse

Ref.	Medidas Size Dimensions	Unidades Units Unités
C-7	10 x 7	12



Rotulador para carteles digitales y rotulación producto

Marker for digital tags and product signages

Marqueur pour les affiches digitales et marquages de produits

Ref.	Medidas Size Dimensions	Unidades Units Unités
C-100		



Inyección con guía para etiqueta, masa roja

Injection with place to fit label, red Material : injected plastic

Stainless steel pin

Injection avec tringle pour étiquette, rouge Matériel: plastique injecté

Pique : acier inox.

Ref.	Medidas Size Dimensions	Unidades Units Unités
C-42-GR	10 x 7	12



Inyección con guía para etiqueta, masa azul

Injection with place to fit label, 10x7 cm, blue

Injection avec tringle pour étiquette, 10x7 cm, bleu

Ref.	Medidas Size Dimensions	Unidades Units Unités
C-42-GAZ	10 x 7	12

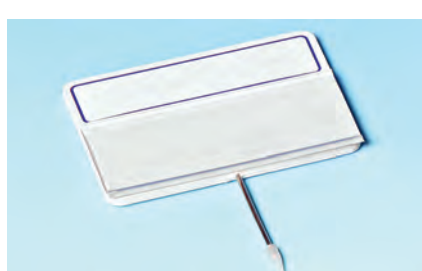

Inyección con guía para etiqueta, blanco

Injection with place to fit label, white

Injection avec tringle pour étiquette, blanc

Ref.	Medidas Size Dimensions	Unidades Units Unités
C-42-G	10 x 7	12



Inyección con guía para etiqueta, masa marrón

Injection with place to fit label, brown

Injection avec tringle pour étiquette, marron

Ref.	Medidas Size Dimensions	Unidades Units Unités
C-42-GM	10 x 7	12

Material : Plástico inyectado - Pincho : Acero inox. - Números : Relieve

Material: Injected Plastic - Pin: Stainless Steel - Numbers: Relief

Matériel : Plastique injecté - Pique: Acier inox. - Chiffres: Relief



Inyección, N° relieve, azul

Injection, num. relief, blue

Injection, num. relief, bleu

Ref.	Medidas Size Dimensions	Unidades Units Unités
C-44-AZ	9 x 7,5	24



Inyección, N° relieve, blanco

Injection, num. relief, white

Injection, num. relief, blanc

Ref.	Medidas Size Dimensions	Unidades Units Unités
C-44-B	9 x 7,5	24



Inyección, N° relieve, crema

Injection, num. relief, beige

Injection, num. relief, beige

Ref.	Medidas Size Dimensions	Unidades Units Unités
C-44-C	9 x 7,5	24



Inyección, N° relieve, marrón

Injection, num. relief, brown

Injection, num. relief, marron

Ref.	Medidas Size Dimensions	Unidades Units Unités
C-44-M	9 x 7,5	24



Inyección, N° relieve, rojo

Injection, num. relief, red

Injection, num. relief, rouge

Ref.	Medidas Size Dimensions	Unidades Units Unités
C-44-R	9 x 7,5	24



Inyección, N° relieve, blanco masa azul

Injection, N° relief, white blue top

Injection, num. relief, blanc tête bleu

Ref.	Medidas Size Dimensions	Unidades Units Unités
C-44-BAZ	9 x 7,5	24



Inyección, N° relieve, blanco masa rojo

Injection, num. relief, 9x7,5 cm, white red top

Injection, num. relief, 9x75, blanc tête rouge

Ref.	Medidas Size Dimensions	Unidades Units Unités
C-44-BR	9 x 7,5	24



Inyección, N° relieve, blanco masa verde

Injection, num. relief, white and green top

Injection, num. relief, blanc et tête vert

Ref.	Medidas Size Dimensions	Unidades Units Unités
C-44-BV	9 x 7,5	24



Inyección, N° relieve, azul

Injection, num. relief, blue
Material: Injected Plastic - Pin: Stainless Steel - Numbers: Relief

injection, num. relief, bleu

Ref.	Medidas Size Dimensions	Unidades Units Unités
C-42-AZ	10 x 7	24



Inyección, Nº relieve, blanco

Injection num. relief, white

Injection, num. relief, blanc

Ref.	Medidas Size Dimensions	Unidades Units Unités
C-42-B	10 x 7	24



Inyección, Nº relieve, crema

Injection num. relief, beige

Injection, num. relief beige

Ref.	Medidas Size Dimensions	Unidades Units Unités
C-42-C	10 x 7	24



Inyección, Nº relieve, masa roja

Injection, num. relief, red

Injection, num. relief, rouge

Ref.	Medidas Size Dimensions	Unidades Units Unités
C-42-R	10 x 7	24



Inyección, Nº relieve, masa green

Injection, num. relief, green

Injection, Nº relief, vert

Ref.	Medidas Size Dimensions	Unidades Units Unités
C-42-V	10 x 7	24



Visera oferta para acoplar a ref. C-44

Offer top for fitting on item C-44

Visière d'offre pour réf. C-44

Ref.	Unidades Units Unités
C-43	12



Arandela para acoplar ref. C-44

Washer for coupling C-44

Rondelle pour raccorder C-44

Ref.	Unidades Units Unités
C-43-A	12

ROTULACIÓN | SIGNAGES | MARQUAGES



Rotulación cartel indicando producto

Tag signage, product indication

Marquage d'affiche, indication de produit

Ref.
C-51



Grabado C-42 - C-44

Signage C-42 - C-44

Marquage C-42 - C-44

Ref.
C-56

Material: Glaspar - Paleta: Inyección - Ganchos: Acero-Inox - Números : Recambiables - Ruedas

Material: Glaspar - Spatula: Injection - Hangers: Stainless Steel - Numbers: changeable - Wheels

Matériel: Glaspar - Palette: Injection - Crochets: Acier Inox. - Chiffres: interchangeable - Roulettes



Frutas, nº relieve, con ganchos

Fruits, num. relief, with hooks

Fruits, num. relief, avec crochets

Ref.	Medidas Size Dimensions	Unidades Units Unités
C-320	13 x 9,5 cm	12



Oferta, Nº recambiable

Offer, Num. interchangeable

Offre, Num. interchangeable

Ref.	Medidas Size Dimensions	Unidades Units Unités
C-34	28 x 23,5	6



Oferta, Nº recambiable

Offer, Num. interchangeable

Offre, Num. interchangeable

Ref.	Medidas Size Dimensions	Unidades Units Unités
C-35	18 x 12,5	12



Oferta kilos, Nº recambiable

Kilo offer, Num. interchangeable

Offre kilo, Num. interchangeable

Ref.	Medidas Size Dimensions	Unidades Units Unités
C-35-K	18 x 12,5	12



Nº recambiable, Paleta

Num. interchangeable, Palette

Num. interchangeable, Palette

Ref.	Medidas Size Dimensions	Unidades Units Unités
C-40	19 x 13	12



Nº recambiable, Ganchos

Num. interchangeable, Hooks

Num. interchangeable, Crochets

Ref.	Medidas Size Dimensions	Unidades Units Unités
C-41	19 x 13	



Nº ruedas, Verde, con rueda para indicar kilo - Unid. 100 grs - 1/4

Num. rotating, Green, Wheel for kilo or unit

Num. roulettes, Vert, Roulette pour kilo ou unité

Ref.	Medidas Size Dimensions	Unidades Units Unités
C-65-VF	11 x 7,5	12



Nº recambiable, 4 dígitos, Paleta

Num. interchangeable, 4 digits, Palette

Num. interchangeable, 4 digits, Palette

Ref.	Medidas Size Dimensions	Unidades Units Unités
C-68	18,5 x 12	12



Num. recambiable, 4 dígitos, Ganchos

Nº interchangeable, 4 digits, Hooks

Nº interchangeable, 4 digits, Crochets

Ref.	Medidas Size Dimensions	Unidades Units Unités
C-69	18,5 x 12	12



Nº ruedas, 4 dígitos, Paleta

Num. rotating, 4 digits, Palette

Num. roulettes, 4 digits, Palette

Ref.	Medidas Size Dimensions	Unidades Units Unités
C-72	18 x 11	12



Nº ruedas, 4 dígitos, 2 Ganchos

Num. rotating, 4 digits, 2 hooks

Num. roulettes, 4 digits, 2 crochets

Ref.	Medidas Size Dimensions	Unidades Units Unités
C-73	18 x 11	12



Oferta kilos, Nº recambiable, Paleta

Kilo offer, Num. interchangeable, Palette

Offre kilo, Nº interchangeable, Palette

Ref.	Medidas Size Dimensions	Unidades Units Unités
C-74	23,5 x 18,5	6



Oferta kilos, Nº recambiable, Ganchos,

Kilo offer, Num. interchangeable, Hooks,

Kilo offer, Num. interchangeable, Crochets

Ref.	Medidas Size Dimensions	Unidades Units Unités
C-75	23 x 18,5	6



Nº ruedas, Paleta

Num. rotating, Palette

Num. rotating, Palette

Ref.	Medidas Size Dimensions	Unidades Units Unités
C-76	22 x 14	12



Frutas, Nº ruedas, Paleta

Fruits, Nº rotating, Palette

Fruits, Nº roulettes, Palette

Ref.	Medidas Size Dimensions
C-76-C	22 x 14



Nº ruedas, Paleta, con num. tecla

Num. rotating, Palette, with product ref.

Num. roulettes, Palette, avec réf. du produit

Ref.	Medidas Size Dimensions	Unidades Units Unités
C-76-T	22 x 14	12



Nº ruedas, Ganchos, con Nº tecla

Num. rotating, Hooks, with product ref.

Num. roulettes, Palette, avec réf. du produit

Ref.	Unidades Units Unités
C-77-T	12



Nº ruedas, Ganchos

Num. rotating, Hooks, Palette

Num. roulettes, Crochets

Ref.	Medidas Size Dimensions	Unidades Units Unités
C-77	22 x 14	12



Frutas, N° ruedas, Ganchos

Fruits, Num. rotating, Hooks

Fruits, Num. roulettes, Crochets

Ref.	Medidas Size Dimensions	Unidades Units Unités
C-77-C		12



Liso pizarra, Paleta

Plane Board, Palette

Num. roulettes, Crochets, Fruits

Ref.	Medidas Size Dimensions	Unidades Units Unités
C-93	19 x 12	12
C-95	24 x 20	12

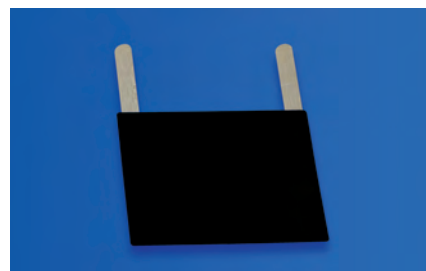

Liso pizarra, Ganchos

Plane board, Hooks

Tableau lisse, Crochets

Ref.	Medidas Size Dimensions	Unidades Units Unités
C-94	19 x 12	12
C-96	24 x 20	12

NÚMEROS RECAMIABLES | CHANGEABLE NUMBERS | *CHIFFRES INTERCHANGEABLES*



Núm. recambiable, arandela

Num. rechargeable, washer

Num. rechargeable, ronelle

Ref.	Medidas Size Dimensions	Unidades Units Unités
C-79	11 x 9 cm	12



Pergamino, núm. recambiable Con pincho acero inoxidable

Scroll, num. interchangeable With stainless steel pin

Parchemin, num. interchangeable Avec pique en acier inox.

Ref.	Medidas Size Dimensions	Unidades Units Unités
C-87	15 x 11 cm	12



Pergamino, núm. recambiable, arandela

Scroll, num. interchangeable, washer

Parchemin, num. interchangeable, rondelle

Ref.	Medidas Size Dimensions	Unidades Units Unités
C-87-A	15 x 11 cm	12



Huevos, núm. recambiable

Eggs, num. interchangeable

Oeufs, num. interchangeable

Ref.	Medidas Size Dimensions	Unidades Units Unités
C-88	15 x 14 cm	6



Pergamino, núm. recambiable

Scroll, num. interchangeable

Parchemin, num. interchangeable

Ref.	Medidas Size Dimensions	Unidades Units Unités
C-89	20 x 15 cm	6



Peana inox con pinza

Stainless stand with pincer

Inox socle avec pince

Ref.	Altura Height Hauteur	Unidades Units Unités
C-205	10 cm	4

SOPORTES CARTELES INYECCIÓN | INJECTION TAGS STAND | SUPPORT AFFICHES INJECTION



Plataforma con tubo

Platform with tube

Plate-forme avec tube

Ref.	Altura Height Hauteur	Color Colour Couleur	Unidades Units Unités
C-1	20 cm	○	12
C-1-N	20 cm	●	12



Pinza para plataforma C-1

Clip platform C-1

Clip plate-forme C-1

Ref.	Color Colour Couleur	Unidades Units Unités
C-1-P		12
C-1PN	●	12



Peana

Stand

Socle

Ref.	Color Colour Couleur	Unidades Units Unités
C-4-B	○	12
C-4-M	●	12



Pinza para cubetas

Pincer trays

Pince bac

Ref.	Unidades Units Unités
C-9	12

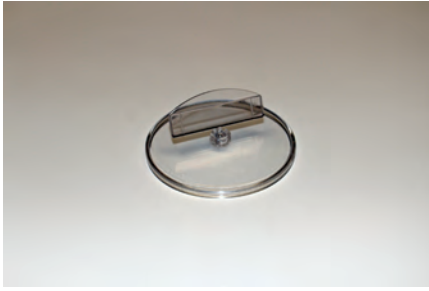

Peana base redonda
Peana base redonda 8,5cm con soporte.

Ref.	Unidades Units Unités
C-210	10



Pinza plástica

Plastic salad clip

Pince en plastique

Ref.	Largo Long Longueur	Unidades Units Unités
C-215-N	80 mm	10
C-215-B	80 mm	10



Peana base redonda
Peana base redonda 8,5 cm con soporte 12,5 cm.

Ref.	Unidades Units Unités
C-211	10



Pinza apertura máxima
Pinza apertura máxima 3 cm con soporte.

Maximum aperture clamp
Maximum opening with support clamp 3 cm.

Pince d'ouverture maximum
Ouverture maximale avec le support de serrage 3 cm.

Ref.	Unidades Units Unités
C-212	10



Pinza apertura máxima
Pinza apertura máxima 1 cm con soporte.

Maximum aperture clamp
Maximum opening with support clamp 1 cm.

Pince d'ouverture maximum
Ouverture maximale avec le support de serrage 1 cm.

Ref.	Unidades Units Unités
C-213	10



Pinza apertura máxima
Pinza apertura máxima 1 cm soporte 15 cm.

Maximum aperture clamp
Maximum aperture support gripper 1 cm 15 cm.

Pince d'ouverture maximum
Ouverture maximale support pince 1 cm à 15 cm.

Ref.	Unidades Units Unités
C-214	10

Material: Glaspar, Números recambiables
 Material: Glaspar, Numbers changeable
 Matériel: Glaspar, Chiffres interchangeable



Polleria Combinada

Poultry store Combined

Volaille Combinée

Ref.	Medidas Size Dimensions
C-25	39 x 35



Lista oficial porcino

Pork official list

Officiel porcin

Ref.	Medidas Size Dimensions
C-26	54 x 48



Lista oficial ternera

Veal official list

Officiel veau

Ref.	Medidas Size Dimensions
C-27	57 x 35



Lista oficial cordero

Lamb official list

Officiel agneau

Ref.	Medidas Size Dimensions
C-28	57 x 35



Cartel listas especiales Superior a 12 x 16, incluido números, fotos y textos.

Special lists tag
 Top a 12 x 16, including numbers photos and text.

Cartel listes spéciales
 Affiche 12 x 16 y compris les numéros, les photos et les textes.

Ref.
C-57

Material: Glaspar, Números recambiables
 Material: Glaspar, Numbers changeable
 Matériel: Glaspar, Chiffres interchangeable



Jamones

Ham

Jambon

Ref.	Medidas Size Dimensions
C-30	40 x 30



Paletas

Shoulder

Épaule

Ref.	Medidas Size Dimensions
C-30-P	40 x 30



Pollos

Chicken

Poulet

Ref.	Medidas Size Dimensions
C-32	40 x 30



Gallinas

Hen

Poule

Ref.	Medidas Size Dimensions
C-33	40 x 30



Conejos

Rabbit

Lapin

Ref.	Medidas Size Dimensions
C-31	40 x 30

CARTELES DESPIECE | CUT TAGS | AFFICHES DÉCOUPE

Material: Glaspar
 Material: Glaspar
 Matériel: Glaspar



Despiece porcino

Pork quartering

Dépeçage porc

Ref.	Medidas Size Dimensions
C-62	60 x 50



Despiece ternera

Veal quartering

Dépeçage veau

Ref.	Medidas Size Dimensions
C-63	60 x 50



Despiece cordero

Lamb quartering

Dépeçage agneau

Ref.	Medidas Size Dimensions
C-64	60 x 50



Triángulo dos caras "Peligro suelo mojado". Material ABS amarillo. 62x30 cm

Triangle two faces "Danger wet ground". Yellow ABS material. 62x30 cm

Triangle deux faces "Danger sol humide". Matériau ABS jaune. 62x30 cm

Ref.

C-500





Guirnalda perejil

Parsley

Persil

Ref.	Largo Long Longueur
X-2500	270 cm



Hiedra

Ivy

Lierre

Ref.	Largo Long Longueur
X-2503	270 cm



Flor de viña

Vine flowers

Fleur de vigne

Ref.	Largo Long Longueur
X-2504	270 cm



Rosas rosas

Pink roses

Roses roses

Ref.	Largo Long Longueur
X-2505	180 cm



Novidad

Christmas

Noël

Ref.	Largo Long Longueur
X-2514	180 cm



Guirnalda tomates

Tomatoes

Tomates

Ref.	Largo Long Longueur
X-2800	200 cm



Guirnalda limones

Lemons

Citrons

Ref.	Largo Long Longueur
X-2801	180 cm



Guirnalda manzanas

Apples

Pommes

Ref.	Largo Long Longueur
X-2804	200 cm



Guirnalda viña verde

Green vine

Vigne vert

Ref.	Largo Long Longueur
X-2509	180 cm

**Hoja lechuga**

Lettuce leaf

Feuille Laitue

Ref.	Unidades Units Unités
X-2530	12

**Hoja helecho**

Fern leaf

Feuille fougère

Ref.	Unidades Units Unités
X-2515	10

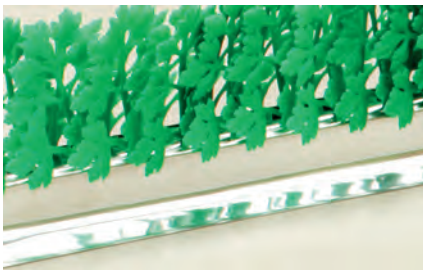
SEPARADORES | SEPARATORS | SÉPARATEURS**Separador Perejil base inox**

Separator Parsley stainless steel base 25 cm

Séparateur Persil base acier inox. 24 cm

Ref.	Largo Long Longueur	Unidades Units Unités
A-1	25 cm	1

**Separador Perejil**

Separator Parsley

Séparateur Persil

Ref.	Largo Long Longueur	Unidades Units Unités
X-0024	24 cm	12

**Separador rosa roja**

Separator red rose

Séparateur roses rouges

Ref.	Largo Long Longueur	Unidades Units Unités
X-0724	24 cm	12





Separador Ciprés verde, base 9,5 x 75

Separator Green cypress, base 9,5 x 75

Séparateur Cyprés vert, base 9,5 x 75

Ref.

X-0100



Separador Verde-rojo, base 9,5 x 75

Separator Green-red, base 9,5 x 75

Séparateur Vert-rouge base 9,5 x 75

Ref.

X-0101



Separador Perejil, base 9,5 x 75

Separator Parsley, base 9,5 x 75

Séparateur Persil, base 9,5 x 75

Ref.

X-0102



Separador Blanco 15 x 75

Separator White 15 x 75

Séparateur Blanc 15 x 75

Ref.

X-0200



Separador Verde 15 x 75

Separator Green 15 x 75

Séparateur Vert 15 x 75

Ref.

X-0201

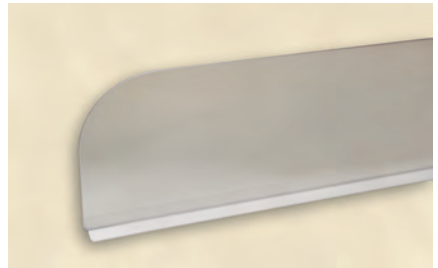

Separador Transparente 15 x 75

Separator Transparent 15 x 75

Séparateur Transparent 15 x 75

Ref.

X-0202



Separador Rojo 15 x 75

Separator Red 15 x 75

Séparateur Rouge 15 x 75

Ref.

X-0203



Separador Negro 15 x 75

Separator Black 15 x 75

Séparateur Noir 15 x 75

Ref.

X-0204

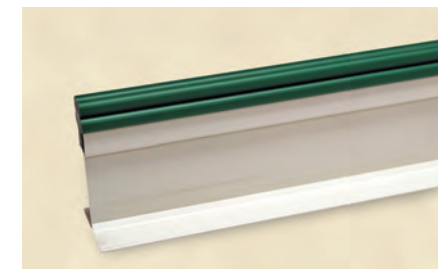

Separador Blanco con adorno verde 7 x 75

Separator White with green decoration 7 x 75

Séparateur Blanc avec ornement vert 7 x 75

Ref.

X-0210



Mejillones con limones

Mussels and lemons

Mouellets et citrons

Ref.

X-2900

Gaviota

Seagull

Gavotte

Ref.

X-2903

Conchas 4 unidades

Shells 4 units

Coquillages 4 unités

Ref.

X-2906

Bogavante

Lobster

Homar

Ref.

X-2901

Truchas

Trouts

Truites

Ref.

X-2904

Bolsa con hielo

Ice bag

Sachet avec glaçons

Ref.

X-2907

Cangrejo de mar

Crab

Crabe

Ref.

X-2902

Estrella de mar - 2 unid.

Starfish - 2 units

Étoile de mer - 2 unités

Ref.

X-2905

Red de pesca

Fishing net

Filet de pêche

Ref.

X-2909

Medidas
Size
Dimensions

200 x 150 cm



Separador PLEXI GLASS

Divider

Séparation

Ref.

X-9005

Medidas
Size
Dimensions

600 x 200

X-6886

800 x 200



Jamón

Ham

Jambon

Ref.

X-2910



CH12-18 - Barreño industrial sin tap

CH12-18 - Industrial tub no lid

CH12-18 - Bassine industriel sans couvercle

Ref.	Medidas Size Dimensions	Capacidad Capacity Capacité
CH-12	35 x 19 cm	12 l
CH-18	39 x 21 cm	18 l

Barreño industrial con tapa

Industrial tub with lid

Bassine industriel avec couvercle

Ref.	Medidas Size Dimensions	Capacidad Capacity Capacité
CH-30	49 x 26 cm	30 l
CH-40	49 x 37 cm	40 l
CH-50	49 x 45 cm	50 l
CH-75	50 x 60 cm	75 l
CH-100	54 x 69 cm	100 l

Cubo con medidor 30x29, asa inox., 13L.

Bin with measure 30x29, stainless steel handle, 13L.

Seau avec mesureur 30x29, anse inox, 13L

Ref.	Medidas Size Dimensions	Capacidad Capacity Capacité
CH-10	30 x 29 cm	13 l

CUBETA, BASE RODANTE | CONTAINER, ROLLING BASE | BAC, BASE ROULANTE



Cubeta azul pescadería

Blue box fishmonger's

Basin bleu poissonnerie

Ref.	Medidas Size Dimensions
CC-14	60 x 40 x 12,5 cm



**Cubeta encajable con tapa integrada azul
Medidas base 50,8 x 33,8**

Blue container stackable with lid
Base measures 50,8 x 33,8

Bac bleu encastrable avec couvercle
Dimensions de base 50,8 x 33,8

Ref.	Medidas Size Dimensions
CC-32	60 x 40 x 32 cm



Base rodante para cubetas con 4 ruedas giratorias de poliamida.

Rolling base with 4 nylon wheels with natural rubber

Base roulante avec 4 roues giratoires en nylon et caoutchouc naturel.

Ref.	Medidas Size Dimensions	Carga Máxima Maximum load Charge maximale
R-40	60 x 40 cm	250 KGS



Cubeta encajables

Container stackable

Bac encastrable

Ref.	Medidas Size Dimensions	Capacidad Capacity Capacité
CH-1	26 x 26 x 16 cm	6 l
CH-2	30 x 30 x 18 cm	10 l
CH-3	34 x 34 x 20 cm	14 l
CH-4	30 x 30 x 12 cm	7,5 l
CH-6	25 x 18 x 23 cm	8 l
CH-7	32 x 29 x 40 cm	26 l



Cubetas con asas apilable y encajable

Container with handles stackable

Bac empilable et encastrable

Ref.	Medidas Size Dimensions	Capacidad Capacity Capacité
CC-20	65 x 45 x 22,5 cm	20 l
CC-40	65 x 45 x 32 cm	40 l
CC-60	65 x 45 x 42,5 cm	60 l
CC-100	77 x 59,5 x 42,5 cm	100 l

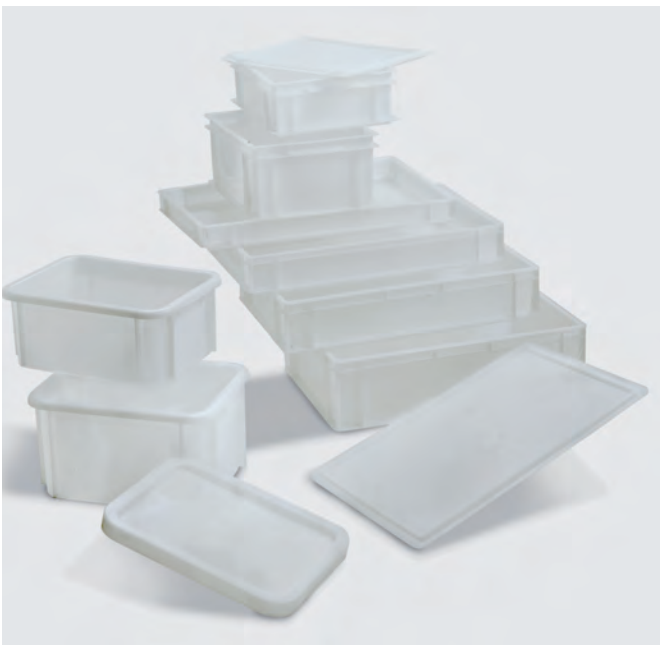

Cubeta apilables

Container stackable

Bac empilable

Ref.	Medidas Size Dimensions	Capacidad Capacity Capacité
CC-9	60 x 40 x 5,5 cm	9 l
CC-10	40 x 30 x 11,8 cm	11 l
CC-12	39,5 x 29,5 x 16 cm	12 l
CC-15	40 x 30 x 17,5 cm	16 l
CC-16	39,5 x 29,5 x 21,5 cm	15 l
CC-19	60 x 40 x 9 cm	19 l
CC-21	60 x 40 x 11,8 cm	21 l
CC-33	60 x 40 x 17 cm	33 l

Tapa

Lid

Couvercle

Ref.	Medidas Size Dimensions
CCT-39	39,5 x 29,5 cm
CCT-40	40 x 30 cm
CCT-60	60 x 40 cm



Honda

Deep

Creux

Ref.	Medidas Size Dimensions
BX-4	33 x 23 x 2,5 cm
BX-5	40 x 30 x 2,5 cm
BX-6	51 x 35 x 2,5 cm
BX-9	36 x 27 x 2,5 cm



Plana

Flat

Plat

Ref.	Medidas Size Dimensions
BXP-2	32 x 22 cm
BXP-3	39 x 29 cm
BXP-4	50 x 34,5 cm
BXP-5	35 x 26 cm

BANDEJAS METACRILATO NEGRA | BLACK METHACRYLATE TRAYS | PLATEAUX MÉTHACRYLATE NOIRS



Honda

Deep

Creux

Ref.	Medidas Size Dimensions
BZ-1	33 x 23 x 2,5 cm
BZ-2	36 x 27 x 2,5 cm
BZ-3	40 x 30 x 2,5 cm
BZ-4	51 x 35,5 x 2,5 cm
BZ-5	30,5 x 16 x 2,5 cm
BZ-6	46 x 16,5 x 2,5 cm
BZ-10	58 x 38,5 x 2,5 cm



Plana

Flat

Plat

Ref.	Medidas Size Dimensions
BZP-1	32 x 22 cm
BZP-2	35 x 26 cm
BZP-3	39 x 29 cm
BZP-4	50 x 34,5 cm



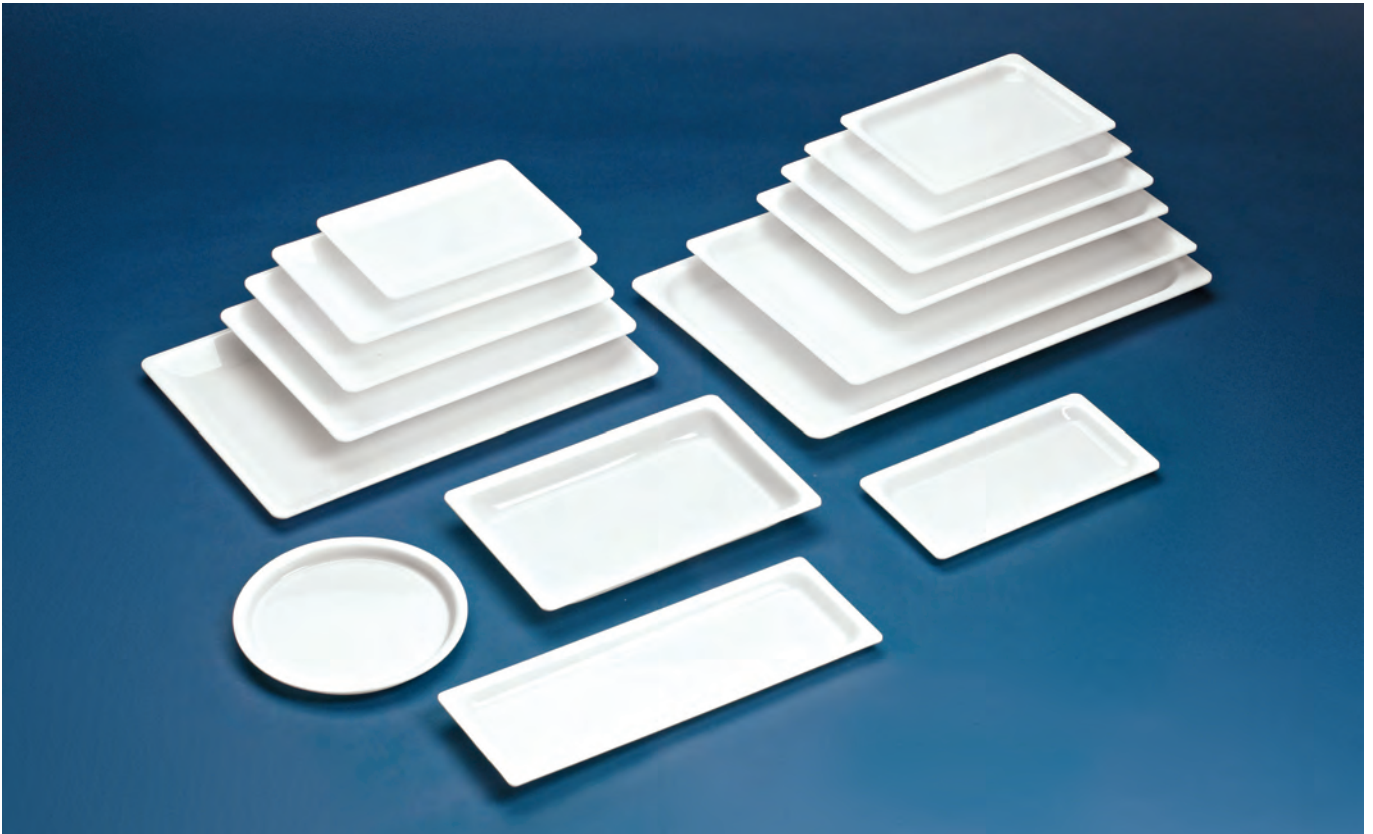

Honda

Deep

Creux

Ref.	Medidas Size Dimensions
BB-1	30,5 x 16 x 2,5 cm
BB-2	16,5 x 46 x 2,5 cm
BB-3	20 x 27 x 2,5 cm
BB-4	23 x 33 x 2,5 cm
BB-5	30 x 40 x 2,5 cm
BB-6	51 x 35,5 x 2,5 cm
BB-9	36 x 27 x 2,5 cm
BB-10	58 x 38,5 x 2,5 cm

Plana

Flat

Plat

Ref.	Medidas Size Dimensions
BBP-1	26 x 19 cm
BBP-2	22 x 32 cm
BBP-3	29 x 39 cm
BBP-4	50 x 34,5 cm
BBP-5	35 x 26 cm

Redonda

Round

Rond

Ref.	Diámetro Diameter Diamètre
BB-8	Ø 24,5 cm

Cubetita

Container

Petit bac

Ref.	Medidas Size Dimensions
BB-7	35,5 x 23,5 x 3,5 cm

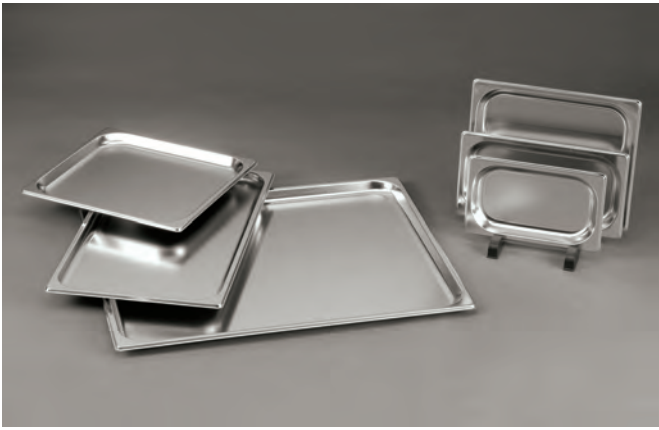

Bandejas acero-inox

Stainless Steel trays

Plateaux acier-inox

Ref.	Tipo Type	Medidas Size Dimensions
GI-2/1-20	2/1	65 x 53 x 2 cm
GI-1/1-20	1/1	53 x 32,5 x 2 cm
GI-2/4-20	2/4	53 x 16,5 x 2 cm
GI-2/3-20	2/3	35,5 x 32,5 x 2 cm
GI-1/2-20	1/2	32,5 x 26,5 x 2 cm
GI-1/3-20	1/3	32,5 x 17,5 x 2 cm
GI-1/4-20	1/4	26,4 x 16,2 x 2 cm



Bandeja autoservicio 3 compartimentos acero inox

Self-service tray
3 compartments stainless steel

Plateau self-service
3 compartiments acier inox

Ref.	Diámetro Diameter Diamètre
BA-3	Ø 28 cm



Bandeja autoservicio

Self-service tray

Plateau self-service

Ref.	Medidas Size Dimensions
BA-5	34,5 x 34,5 x 3,5 cm



Bandejas Pasteleras Acero Inox. / Aluminio

Stainless steel / aluminum pastry trays

Ref.	Medidas Size Dimensions
BAC-1	60 x 40 x 1 cm
BAL-1	60 x 40 x 1 cm



Cubetas por inyección-s

S injection trays

Bacs par injection-s

Ref.	Medidas Size Dimensions	Capacidad Capacity Capacité
BC-0	30 x 20 x 6 cm	2 l
BC-1	34 x 23 x 7 cm	3 l
BC-2	43 x 28 x 7,5 cm	5 l
BC-3	48 x 33 x 7,8 cm	8 l
BC-4	54 x 38 x 8,3 cm	10 l
BC-5	60 x 40 x 9 cm	15 l

* Otros colores consultar

* Other colors consult

* Autres couleurs consulter

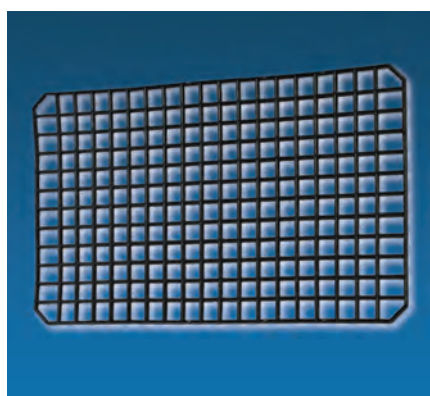

Rejillas para cubetas negras

Black tray grille

Grille pour bac noir

Ref.	Medidas Size Dimensions
BCR-5-N	39,5 x 24,7 cm

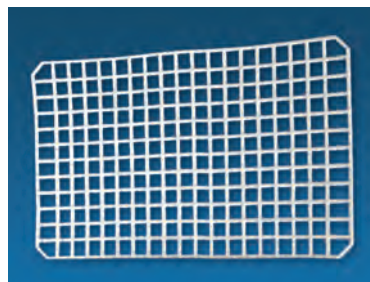

Rejillas blancas para cubetas

White grids for buckets

Grilles blanches pour seaux

Ref.	Medidas Size Dimensions
BCR-5	39,5 x 24,7 cm

Ref.	Modelo rejillas Grid model Modèle de grille
------	---

BCR-0 Para BC-0

BCR-1 Para BC-1

BCR-2 Para BC-2

BCR-3 Para BC-3

BCR-4 Para BC-4



Tapas transparentes

Transparent lids

Couvercles transparents

Ref.	Modelo tapas Caps model Modèle de casquettes
------	--

BCT-0 Para BC-0

BCT-1 Para BC-1

BCT-2 Para BC-2

BCT-3 Para BC-3



Cubetas por inyección-s negras

Injection-s containers black

Bacs par injection-s noir

Ref.	Medidas Size Dimensions	Capacidad Capacity Capacité
BC-0-N	30 x 20 x 6 cm	2 l
BC-1-N	34 x 23 x 7 cm	3 l
BC-2-N	43 x 28 x 7,5 cm	5 l
BC-3-N	48 x 33 x 7,8 cm	8 l
BC-4-N	54 x 38 x 8,3 cm	10 l



Bandejas por inyección alta presión

High pressure injection trays

Plateaux par injection haute pression

Ref.	Medidas Size Dimensions
BI-11	29 x 20 x 2 cm
BI-12	33 x 22,5 x 2 cm
BI-13	40 x 29 x 2 cm
BI-14	60 x 40 x 2 cm



Bandejas ABS para carros R-10/R-20

ABS tray

Plateaux à pâtisserie en acier inoxydable / aluminium

Ref.	Medidas Size Dimensions	Color Colour Couleur
BI-15-B	58,5 x 41 x 2,5 cm	○
BI-15-N	58,5 x 41 x 2,5 cm	●
BI-15-R	58,5 x 41 x 2,5 cm	●

BANDEJAS POR INYECCIÓN BAJA PRESIÓN | LOW PRESSURE INJECTION TRAYS | PLATEAUX PAR INJECTION BASSE PRESSION



Bandejas por inyección baja presión

Low pressure injection trays

Plateaux par injection basse pression

Ref.	Medidas Size Dimensions
BI-21	29 x 20 x 2 cm
BI-22	33 x 22,5 x 2 cm
BI-23	40 x 29 x 2 cm



Bandejas por inyección presión negra

Low pressure injection trays black

Plateaux par injection basse pression noir

Ref.	Medidas Size Dimensions
BI-21-N	29 x 20 x 2 cm
BI-22-N	33 x 22,5 x 2 cm
BI-23-N	40 x 29 x 2 cm

Cubetas gastronorm policarbonato. Temperatura - 40° + 110°

Gastronorm polycarbonate containers. Temperature - 40° + 110°

Bacs gastronorm polycarbonate. Température - 40° + 110°



Ref.	Tipo Type Type	Medidas Size Dimensions	
GP-2/1-200	2/1	65 x 53 x 20 cm	
GP-1/1-65	1/1	53 x 32,5 x 6,5 cm	
GP-1/1-100	1/1	53 x 32,5 x 10 cm	
GP-1/1-150	1/1	53 x 32,5 x 15 cm	
GP-1/1-200	1/1	53 x 32,5 x 20 cm	
GP-1/2-65	1/2	32,5 x 26,5 x 6,5 cm	
GP-1/2-100	1/2	32,5 x 26,5 x 10 cm	
GP-1/2-150	1/2	32,5 x 26,5 x 15 cm	
GP-1/2-200	1/2	32,5 x 26,5 x 20 cm	
GP-1/3-65	1/3	32,5 x 17,5 x 6,5 cm	
GP-1/3-100	1/3	32,5 x 17,5 x 10 cm	
GP-1/3-150	1/3	32,5 x 17,5 x 15 cm	
GP-1/3-200	1/3	32,5 x 17,5 x 20 cm	
GP-1/4-65	1/4	26,4 x 16,2 x 6,5 cm	
GP-1/4-100	1/4	26,4 x 16,2 x 10 cm	
GP-1/4-150	1/4	26,4 x 16,2 x 15 cm	
GP-1/4-200	1/4	26,4 x 16,2 x 20 cm	
GP-1/6-65	1/6	17,6 x 16,2 x 6,5 cm	
GP-1/6-100	1/6	17,6 x 16,2 x 10 cm	
GP-1/6-150	1/6	17,6 x 16,2 x 15 cm	
GP-1/6-200	1/6	17,6 x 16,2 x 20 cm	
GP-1/9-65	1/9	17,6 x 10,8 x 6,5 cm	
GP-1/9-100	1/9	17,6 x 10,8 x 10 cm	

Tapas policarbonato

Polycarbonate lids

Couvercles polycarbonate

Ref.	Tipo Type Type	Medidas Size Dimensions
GPT 2/1	2/1	65 x 53 cm
GPT 1/1	1/1	53 x 32,5 cm
GPT 1/2	1/2	32,5 x 26,5 cm
GPT 1/3	1/3	32,5 x 17,5 cm
GPT 1/4	1/4	26,4 x 16,2 cm
GPT 1/6	1/6	17,6 x 16,2 cm
GPT 1/9	1/9	17,6 x 10,8 cm

Doble fondo perforado policarbonato

Polycarbonate perforated double base

Double fond perforé polycarbonate

Ref.	Tipo Type Type	Medidas Size Dimensions
GPFP-2/1	2/1	56,5 x 44,5 cm
GPFP-1/1	1/1	46,5 x 26,5 cm
GPFP-1/2	1/2	26,5 x 20,5 cm

Cubetas gastronorm acero inoxidable. AISI 304 18/10

Stainless steel gastronorm containers. AISI 304 18/10

Bacs gastronorm acier inox. AISI 304 18/10



Ref.	Tipo Type Type	Medidas Size Dimensions	
GI-2/1-20	2/1	65 x 53 x 2 cm	
GI-2/1-40	2/1	65 x 53 x 4 cm	
GI-2/1-65	2/1	65 x 53 x 6,5 cm	
GI-2/1-100	2/1	65 x 53 x 10 cm	
GI-2/1-150	2/1	65 x 53 x 15 cm	
GI-2/1-200	2/1	65 x 53 x 20 cm	
GI-1/1-20	1/1	53 x 32,5 x 2 cm	
GI-1/1-40	1/1	53 x 32,5 x 4 cm	
GI-1/1-65	1/1	53 x 32,5 x 6,5 cm	
GI-1/1-100	1/1	53 x 32,5 x 10 cm	
GI-1/1-150	1/1	53 x 32,5 x 15 cm	
GI-1/1-200	1/1	53 x 32,5 x 20 cm	
GI-2/3-20	2/3	35,5 x 32,5 x 2 cm	
GI-2/3-40	2/3	35,5 x 32,5 x 4 cm	
GI-2/3-65	2/3	35,5 x 32,5 x 6,5 cm	
GI-2/3-100	2/3	35,5 x 32,5 x 10 cm	
GI-2/3-150	2/3	35,5 x 32,5 x 15 cm	
GI-2/3-200	2/3	35,5 x 32,5 x 20 cm	
GI-1/2-20	1/2	32,5 x 26,5 x 2 cm	
GI-1/2-40	1/2	32,5 x 26,5 x 4 cm	
GI-1/2-65	1/2	32,5 x 26,5 x 6,5 cm	
GI-1/2-100	1/2	32,5 x 26,5 x 10 cm	
GI-1/2-150	1/2	32,5 x 26,5 x 15 cm	
GI-1/2-200	1/2	32,5 x 26,5 x 20 cm	
GI-1/3-20	1/3	32,5 x 17,5 x 2 cm	
GI-1/3-40	1/3	32,5 x 17,5 x 4 cm	
GI-1/3-65	1/3	32,5 x 17,5 x 6,5 cm	
GI-1/3-100	1/3	32,5 x 17,5 x 10 cm	
GI-1/3-150	1/3	32,5 x 17,5 x 15 cm	
GI-1/3-200	1/3	32,5 x 17,5 x 20 cm	
GI-1/4-20	1/4	26,4 x 16,2 x 2 cm	
GI-1/4-40	1/4	26,4 x 16,2 x 4 cm	
GI-1/4-65	1/4	26,4 x 16,2 x 6,5 cm	
GI-1/4-100	1/4	26,4 x 16,2 x 10 cm	
GI-1/4-150	1/4	26,4 x 16,2 x 15 cm	
GI-1/4-200	1/4	26,4 x 16,2 x 20 cm	



Ref.	Tipo	Medidas		Precio
	Type	Size		
	Type	Dimensions		
GI-1/6-65	1/6	17,6 x 16,2 x 6,5 cm		13,50
GI-1/6-100	1/6	17,6 x 16,2 x 10 cm		16,50
GI-1/6-150	1/6	17,6 x 16,2 x 15 cm		23,50
GI-1/6-200	1/6	17,6 x 16,2 x 20 cm		37,00
GI-1/9-65	1/9	17,6 x 10,8 x 6,5 cm		12,50
GI-1/9-100	1/9	17,6 x 10,8 x 10 cm		17,50

Cubetas gastronorm perforadas acero inoxidable

Stainless steel gastronorm perforated containers

Bacs gastronorm perforées acier inox



Ref.	Tipo	Medidas	
	Type	Size	
	Type	Dimensions	
GIP-2/1-20	2/1	65 x 53 x 2 cm	
GIP-2/1-40	2/1	65 x 53 x 4 cm	
GIP-2/1-65	2/1	65 x 53 x 6,5 cm	
GIP-1/1-20	1/1	53 x 32,5 x 2 cm	
GIP-1/1-40	1/1	53 x 32,5 x 4 cm	
GIP-1/1-65	1/1	53 x 32,5 x 6,5 cm	
GIP-1/1-100	1/1	53 x 32,5 x 10 cm	
GIP-1/1-150	1/1	53 x 32,5 x 15 cm	
GIP-1/1-200	1/1	53 x 32,5 x 20 cm	
GIP-1/2-65	1/2	32,5 x 26,5 x 6,5 cm	
GIP-1/2-100	1/2	32,5 x 26,5 x 10 cm	
GIP-1/2-150	1/2	32,5 x 26,5 x 15 cm	
GIP-1/2-200	1/2	32,5 x 26,5 x 20 cm	

Tapas de cubierta gastronorm acero inox.

Lids for stainless steel gastronorm container

Couvercles de bac gastronorm acier inox.

Ref.	Tipo	Medidas
	Type	Size
	Type	Dimensions
GIT-1/1	1/1	53 x 32,5 cm
GIT-2/3	2/3	35,5 x 32,5 cm
GIT-1/2	1/2	32,5 x 26,5 cm
GIT-1/3	1/3	32,5 x 17,5 cm
GIT-1/4	1/4	26,4 x 16,2 cm
GIT-1/6	1/6	17,6 x 16,2 cm
GIT-1/9	1/9	17,6 x 10,8 cm

Tapas acero inoxidable hermética

Stainless steel tight lids

Couvercles acier inoxydable hermétique

Ref.	Tipo	Medidas
	Type	Size
	Type	Dimensions
GITH-1/1	1/1	53 x 32,5 cm
GITH-2/3	2/3	35,5 x 32,5 cm
GITH-1/2	1/2	32,5 x 26,5 cm
GITH-1/3	1/3	32,5 x 17,5 cm
GITH-1/4	1/4	26,4 x 16,2 cm
GITH-1/6	1/6	17,6 x 16,2 cm

0 2 CUBETAS GASTRONORM ACERO INDOXIDABLE | STAINLESS STEEL GASTRONORM CONTAINERS | BACS GASTRONORM ACIER INOX

Doble fondo perforado acero inoxidable

Stainless steel double base perforated

Double fond perforé acier inox

Ref.	Tipo Type	Medidas Size Dimensions
GIFP-2/1	2/1	59 x 47 cm
GIFP-1/1	1/1	47 x 27 cm
GIFP-2/3	2/3	29,5 x 26,5 cm
GIFP-1/2	1/2	26,5 x 20,5 cm

Separadores acero inoxidable

Stainless steel separators

Séparateurs acier inoxydable

Ref.	Tipo Type	Medidas Size Dimensions
GIS-530	1/1	53 x 2 cm
GIS-325	1/2	32,5 x 2 cm

CUBETAS GASTRONORM PLEXILINE | PLEXILINE GASTRONORM CONTAINERS | BACS GASTRONORM PLEXILINE

Metacrilato acrílico. Apto lavavajillas. No apto para horno-microondas

Acrylic methacrylate. Dishwasher safe. Not suitable for oven-microwave

Méthacrylate acrylique. Lave-vaisselle. Ne convient pas au four-micro-ondes

System gastronorm, negro. Temperatura - 20° + 80°

System gastronorm, black. Temperature - 20° + 80°

System gastronorm, noir. Température - 20° + 80°



Ref.	Tipo Type	Medidas Size Dimensions
BP-GN-1/1-17-N	1/1	53 x 32,5 x 1,7 cm
BP-GN 1/1-50-N	1/1	53 x 32,5 x 5 cm
BP-GN-1/2-17-N	1/2	32,5 x 26,5 x 1,7 cm
BP-GN 1/2-50-N	1/2	32,5 x 26,5 x 5 cm
BP-GN 1/3-17-N	1/3	32,5 x 17,6 x 1,7 cm
BP-GN 1/3-50-N	1/3	32,5 x 17,6 x 5 cm
BP-GN 1/4-17-N	1/4	26,5 x 16,2 x 1,7 cm
BP-GN 1/4-50-N	1/4	26,5 x 16,2 x 5 cm
BP-GN 1/5-17-N	1/5	26,5 x 20 x 1,7 cm
BP-GN 1/5-50-N	1/5	26,5 x 20 x 5 cm
BP-GN 1/6-50-N	1/6	17,6 x 16,2 x 5 cm
BP-GN 1/9-50-N	1/9	17,6 x 10,8 x 5 cm
BP-GN 2/4-17-N	2/4	53 x 16,2 x 1,7 cm
BP-GN 2/5-17-N	2/5	53 x 20 x 1,7 cm
BP-GN 3/4-17-N	3/4	48,7 x 26,5 x 1,7 cm
BP-GN 3/4-50-N	3/4	48,7 x 26,5 x 5 cm
BP-GN 5/4-40-N	5/4	81 x 26,5 x 4 cm



Tapas transparente

Transparent lid

Couvercle transparent

Ref.	Tipo Type Type	Medidas Size Dimensions
BPT-1/1-T	1/1	53 x 32,5 cm
BPT-1/2-T	1/2	32,5 x 26,5 cm
BPT-1/3-T	1/3	32,5 x 17,6 cm
BPT-1/4-T	1/4	26,5 x 16,2 cm
BPT-1/5-T	1/5	26,5 x 20 cm
BPT-2/5-T	2/5	53 x 20 cm
BPT-3/4-T	3/4	48,7 x 26,5 cm



Rejillas negro

Black grid

Grille noir

Ref.	Tipo Type Type	Medidas Size Dimensions
BPR-1/1-N	1/1	53 x 32,5 cm
BPR-1/2-N	1/2	32,5 x 26,5 cm
BPR-1/3-N	1/3	32,5 x 17,6 x 8 cm
BPR-1/4-N	1/4	26,5 x 16,2 cm
BPR-1/5-N	1/5	26,5 x 20 cm



Triángulo

Triangle

Triangle

Ref.	Medidas Size Dimensions	Altura Height Hauteur
BPTR-27-20-N	27 x 27 x 37 cm	2 cm
BPTR-40-20-N	40 x 40 x 56,5 cm	2 cm
BPTR-40-50-N	40 x 40 x 56,5 cm	5 cm





9 Bandejas + escalera
 9 trays + step
 9 plateaux + escalier
Temperatura - 20° + 80°
 Temperature - 20° + 80°
 Température - 20° + 80°



Escalera anfiteatro

Step amphitheater

Escalier amphithéâtre

Ref.	Medidas Size Dimensions
BPA-ANFI	80 x 80 x 6,5 cm

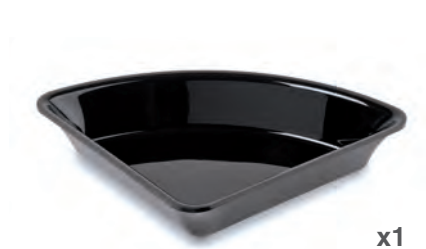

1/4 luna 90° negro

1/4 moon 90° black

1/4 lune 90° noir

Ref.	Medidas Size Dimensions
BPA-90-50-N	26,5 x 26,5 x 5 cm

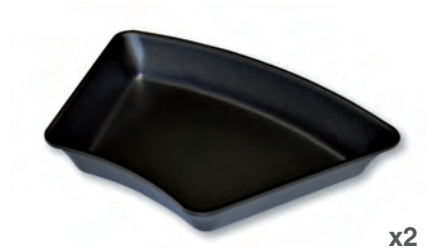

Esquina 45° negro

Corner 45° black

Coin 45° noir

Ref.	Tipo Type Type
BPA-45-50-N	39/22 x 26,5 x 5,0 cm



Esquina 22,5° negro

Corner 22,5° black

Coin 22,5° noir

Ref.	Tipo Type Type
BPA-22G-50-N	30/21 x 26,0 x 5,0 cm



Triángulo izquierdo negro

Left triangle black

Triangle gauche noir

Ref.	Tipo Type Type
BPA-TI-50-N	53 x 30 x 5,0 cm



Triángulo derecho negro

Right triangle black

triangle droite noir

Ref.	Tipo Type Type
BPA-TD-50-N	53 x 30 x 5,0 cm

13 Bandejas + escalera

13 trays + step

13 plateaux + escalier

Temperatura - 20° + 80°

Temperature - 20° + 80°

Température - 20° + 80°

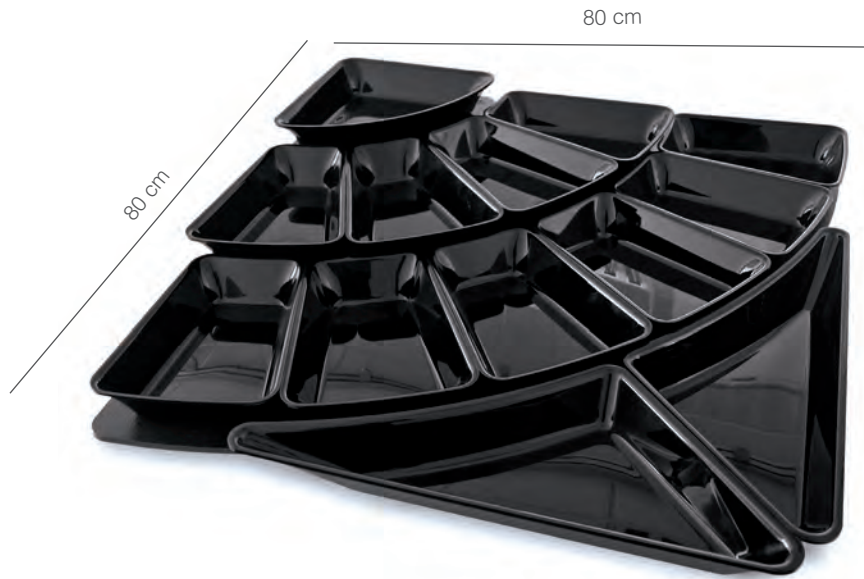

Escalera anfiteatro

Step amphitheater

Escalier amphithéâtre

Ref.	Medidas Size Dimensions
BPA-ANFI	80 x 80 x 6,5 cm



1/4 luna 90° negro

1/4 moon 90° black

1/4 lune 90° noir

Ref.	Medidas Size Dimensions
BPA-90-50-N	26,5 x 26,5 x 5 cm



Esquina 22,5° negro

Corner 22,5° black

Coin 22,5° noir

Ref.	Tipo Type Type
BPA-22P-50-N	20/11 x 26,5 x 5,0 cm



Esquina 15° negro

Corner 15° black

Coin 15° noir

Ref.	Tipo Type Type
BPA-15-50-N	20/14 x 26,5 x 5,0 cm



Triángulo izquierdo negro

Left triangle black

Triangle gauche noir

Ref.	Tipo Type Type
BPA-TI-50-N	53 x 30 x 5,0 cm



Triángulo derecho negro

Right triangle black

triangle droite noir

Ref.	Tipo Type Type
BPA-TD-50-N	53 x 30 x 5,0 cm



Oval 420 x 270 mm H30

Oval 420 x 270 mm H30

Oval 420 x 270 mm H30

Ref.	Medidas Size Dimensions
BP-10063-N	42 x 27 x 3 cm

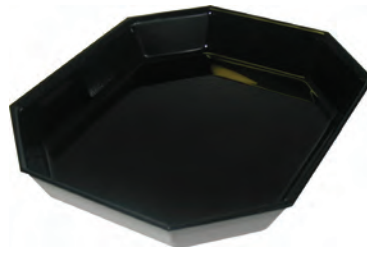

Octo 265 x 200 mm H50 GN1/5

Octo 265 x 200 mm H50 GN1/5

Octo 265 x 200 mm H50 GN1/5

Ref.	Medidas Size Dimensions
BP-6960-N	26,5 x 20 x 5 cm



Octo 265 x 325 mm H45 GN1/2

Octo 265 x 325 mm H45 GN1/2

Octo 265 x 325 mm H45 GN1/2

Ref.	Medidas Size Dimensions
BP-5355-N	26,5 x 32,5 x 4,5 cm



Oval 265 x 200 mm H 65 mm GN1/5

Oval 265 x 200 mm H 65 mm GN1/5

Oval 265 x 200 mm H 65 mm GN1/5

Ref.	Medidas Size Dimensions
BP-6665-N	26,5 x 20 x 6,5 cm



Oval 265 x 325 mm H 65 mm GN1/2

Oval 265 x 325 mm H 65 mm GN1/2

Oval 265 x 325 mm H 65 mm GN1/2

Ref.	Medidas Size Dimensions
BP-6661-N	26,5 x 32,5 x 6,5 cm



Redonda Ø 300 mm H 65 mm

Round Ø 300 mm H 65 mm

Round Ø 300 mm H 65 mm

Ref.	Altura Height Hauteur	Diámetro Diameter Diamètre
BP-6670-N	6,5 cm	Ø 30 cm



Redonda/Exa 175 mm H 80 mm 1,5l

Round/Hexa 175 mm H 80 mm 1,5l

Round/Hexa 175 mm H 80 mm 1,5l

Ref.	Altura Height Hauteur	Diámetro Diameter Diamètre
BP-4013-N	8 cm	Ø 17,5 cm



Redonda/Exa 215 mm H 80 mm 2,5l

Round/Hexa 215 mm H 80 mm 2,5l

Round/Hexa 215 mm H 80 mm 2,5l

Ref.	Altura Height Hauteur	Diámetro Diameter Diamètre
BP-6675-N	8 cm	Ø 21,5 cm

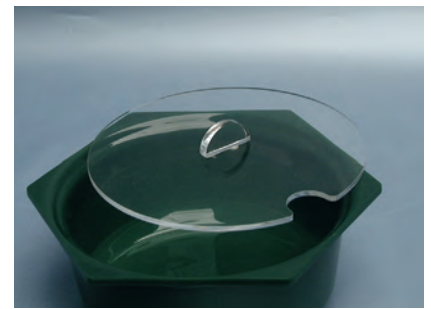

Tapa Plexiline redonda/hexa transparente

Plexiline lid round/hexa transparent

Couvercle plexiline roud/hexa transparent

Ref.	Diámetro Diameter Diamètre	Para For Pour
BPT-4015	Ø 175	Ref. BP-4013-N
BPT-6680	Ø 215	Ref. BP-6675-N



Base 8 x 1,5l Redonda/Exa. HIPS 800x400 mm H 80 mm. Para ref. BP-4013-N.

Holder 8 x 1,5l Round/Hex. HIPS 800x400 mm H 80 mm. For ref. BP-4013-N.

Holder 8 x 1,5l Rond/Hex. HIPS 800x400 mm H 80 mm. Pour ref. BP-4013-N.

Ref.	Medidas Size Dimensions
BPB-25140	80 x 40 x 8 cm



Cubeta concha 270x250 mm H 70 mm

Shelf Shell 270x250 mm H 70 mm

Seau Coquille 270x250 mm H 70 mm

Ref.	Medidas Size Dimensions
BP-5356-N	27 x 25 x 7 cm



Cubeta Huevo 300x210 mm H 75 mm

Egg shelf 300x210 mm H 75 mm

Seau Oeuf 300x210 mm H 75 mm

Ref.	Medidas Size Dimensions
BP-5921-N	30 x 21 x 7,5 cm



Yin Yang 300 mm H 65 mm

Yin Yang 300 mm H 65 mm

Yin Yang 300 mm H 65 mm

Ref.	Altura Height Hauteur	Diámetro Diameter Diamètre
BP-5869-N	6,5 cm	Ø 30 cm



ACCESORIOS | ACCESSORIES | ACCESOIRES



Escalón 3 niveles 500x800 mm H 80 mm

Step 3 levels 500x800 mm H 80 mm

Étape 3 niveaux 500x800 mm H 80 mm

Ref.	Medidas Size Dimensions
BPB-9232-N	500 x 800 x 80 mm

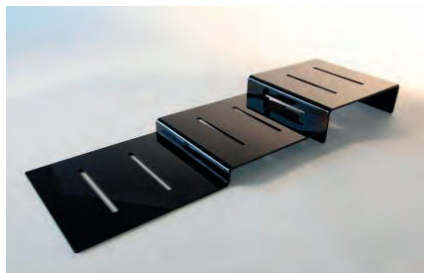

Escalón 3 niveles 250x800 mm H 80 mm

Step 3 levels 250x800 mm H 80 mm

Étape 3 niveaux 250x800 mm H 80 mm

Ref.	Medidas Size Dimensions
BPB-10569-N	250 x 800 x 80 mm



Escalón 1 nivel 624x280 mm H 75 mm

Step 1 level 624x280 mm H 75 mm

Étape 1 niveau 624x280 mm H 75 mm

Ref.	Medidas Size Dimensions
BPB-17068-N	624 x 280 x 75 mm



Escalón 1 nivel 624x280 mm H 35 mm

Step 1 level 624x280 mm H 35 mm

Étape 1 niveau 624x280 mm H 35 mm

Ref.	Medidas Size Dimensions
BPB-17069-N	624 x 280 x 35 mm



Escalón 1 nivel 312x280 mm H 75 mm

Step 1 level 312x280 mm H 75 mm

Étape 1 niveau 312x280 mm H 75 mm

Ref.	Medidas Size Dimensions
BPB-17071-N	312 x 280 x 75 mm



Escalón 1 nivel 312x280 mm H 35 mm

Step 1 level 312x280 mm H 35 mm

Étape 1 niveau 312x280 mm H 35 mm

Ref.	Medidas Size Dimensions
BPB-17070-N	312 x 280 x 35 mm



Pala de picar

Spoon minced

Pelle à hacher

Ref.	Largo Long Longueur
BP-1946-N	260 mm



Cuchara

Spoon

Cuillère

Ref.	Largo Long Longueur
BP-6901-N	240 mm



Cuchara perforadora

Perforated spoon

Cuillère perforée

Ref.	Largo Long Longueur
BP-14330-N	250 mm



Expositor de sandwich

Sandwich display

Porte Sandwich

Ref.	Medidas Size Dimensions
BP-9327-N	520 x 135 x 50 mm



Pinza plástica

Plastic salad clip

Pince en plastique

Ref.	Largo Long Longueur	Unidades Units Unités
C-215-N	80 mm	10
C-215-B	80 mm	10



Base giratoria 80 cm

Rotating base 80 cm

Base tournante 80 cm

Ref.	Altura Height Hauteur	Diámetro Diameter Diamètre
BPC-24544-N	5 mm	Ø 800 mm



x4

Triángulo

Triangle

Triangle

Ref.	Medidas Size Dimensions
BPC-22861-N	325 x 158 x 60 mm



x8

GN 1/5 265x265 mm

GN 1/5 265x265 mm

GN 1/5 265x265 mm

Ref.	Medidas Size Dimensions
BPC-22860-N	265 x 265 x 80 mm



x1

Ensaladera Redonda 2,5l

Round salad dish 2,5l

Assiette à salade ronde 2,5l

Ref.	Altura Height Hauteur	Diámetro Diameter Diamètre
BPC-22866-N	80 mm	Ø 225 mm

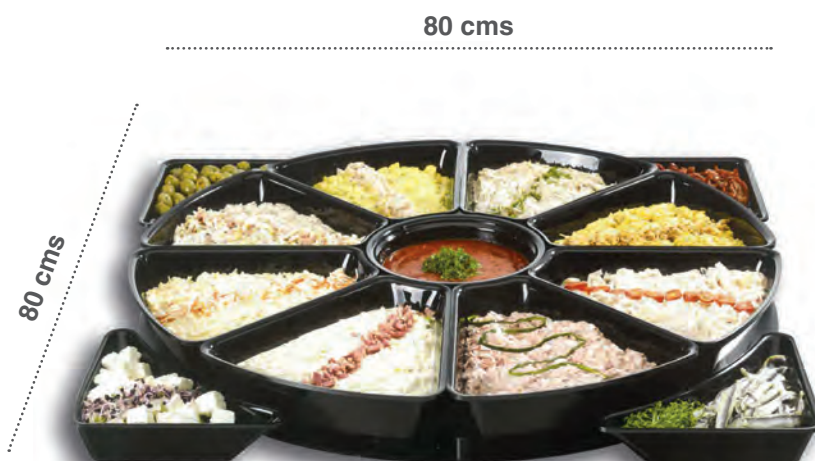



0

3

**Picadoras, Picadora refrigerada, Cuchillas
Placas, Empujadores picadoras, Cortadoras,
Ralladora, Exprimidor, Cortadora multifunción,
Enternecedor de carne, Cutters, Molino,
Afiladoras, Cintas de sierra.**

Mincers, Refrigerated mincers, Blades plates,
Mincer pusher, Slicer, Grater, Juicer, Multi-
purpose slicer, Meat tenderizer, Cutters, Mill,
Sharpener, Band saws.

*Hachoirs, Hachoirs refrigerés, Lames plaques,
Poussoir hachoirs, Trancheuse, Râpes, Presse,
Decoupoir multifonction, Attendrissant, Cutter,
Moulin, Aiguiseur, Scies à ruban.*

63 - 86

Picadora de carne

Boca 12. Cuerpo: acero inoxidable. Grupo picador: acero inoxidable. Cuchilla autoafilante. Interruptor: invertidor de marcha. Potencia 1 HP. Motor: trifásico 220/380 V. Producción: 120 kg/h

Meat mincer

Outlet: 12. Body: stainless steel. Mincer set: stainless steel. Self-sharpening blade. Reverse switch. Power 1 HP. Engine : three phase 220 / 380. Production 120 kg/h.

Hachoir à viande

Goulot: 12. Corps: acier inoxydable. Groupe hachoir: acier inoxydable. Couteau: auto aigiseur. Interrupteur: inverseur. Puissance: 1 HP. Moteur : triphase 220/380. Production: 120 kg.

Picadora de carne

Boca 12. Cuerpo: acero inoxidable. Grupo picador: acero inoxidable. Cuchilla autoafilante. Interruptor: invertidor de marcha. Potencia: 1 HP. Motor: monofásico 220 V. Producción: 120 kg/h

Meat mincer

Outlet: 12. Body: stainless steel. Mincer set: stainless steel. Self-sharpening blade. Reverse switch. Power 1 HP. Engine: one phase 220. Production 120 kg/h.

Goulot: 12. Corps: acier inoxydable. Groupe hachoir: acier inoxydable. Couteau: auto aigiseur. Interrupteur: inverseur. Puissance: 1 HP. Moteur: monophasé 220. Production 120 kg.

Ref.	Peso Weight Poids
MP-12MEC-T	23 kg

Ref.	Peso Weight Poids
MP-12MEC-M	23 kg



Despiece / Quartering / Dépeçage

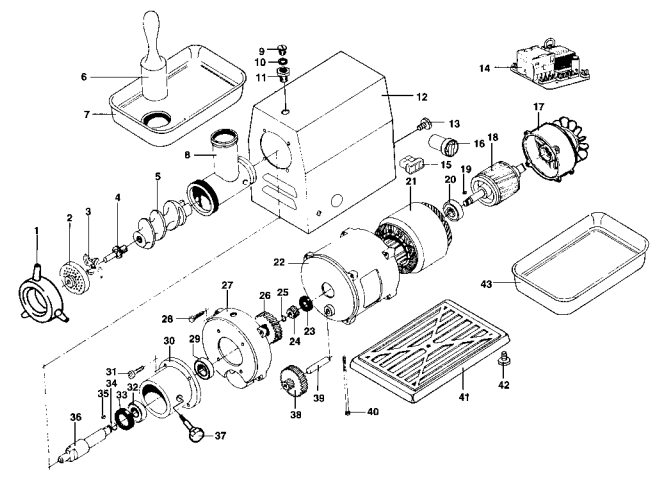

Medidas / Size / Dimensions

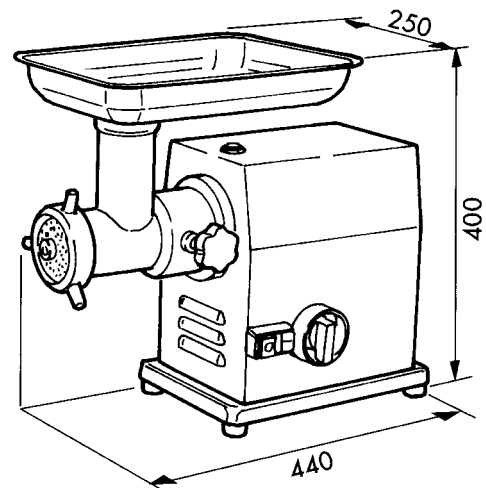

Picadora de carne

Boca: 22. Cuerpo: acero inoxidable. Grupo picador: acero inoxidable. Cuchilla: autoafilante. Interruptor: invertidor de marcha. Potencia. 1 HP. Motor: trifásico 220/380. Producción: 130 kg/h

Meat mincer

Outlet: 22. Body: stainless steel. Mincer set: stainless steel. Blade: self-sharpening. Switch: reverse switch. Power: 1 HP. Engine: three phase 220/380 V. Production: 130 Kg/h

Hachoirs à viande

Goulot: 22. Corps: acier inoxydable. Groupe hachoir: acier inoxydable. Couteau: auto aiguseur. Interrupteur: inverseur. Puissance 1 HP. Moteur: thiphasé 220/380 V. Production 130 kg/h

Picadora de carne

Boca: 22. Cuerpo: acero inoxidable. Grupo picador: acero inoxidable. Cuchilla: autoafilante. Interruptor: invertidor de marcha. Potencia. 1 HP. Motor: monofásico 220 V. Producción: 130 kg/h

Meat mincer

Outlet: 22. Body: stainless steel. Mincer set: stainless steel. Blade: self-sharpening. Switch: reverse switch. Power: 1 HP. Engine: one phase 220 V. Production: 130 Kg/h

Hachoirs à viande

Goulot: 22. Corps: acier inoxydable. Groupe hachoir: acier inoxydable. Couteau: auto aiguseur. Interrupteur: inverseur. Puissance 1 HP. Moteur: monophasé 220 V. Production 130 kg/h

Ref.	Peso Weight Poids
MP-22 EURO-T	23 kg

Ref.	Peso Weight Poids
MP-22 EURO-M	23 kg



Despiece / Quartering / Dépeçage

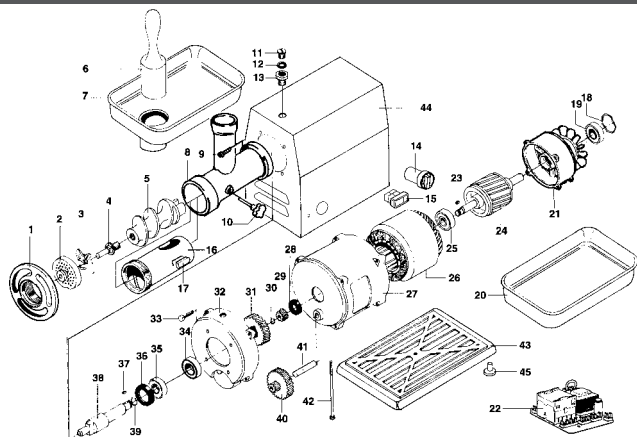

Medidas / Size / Dimensions

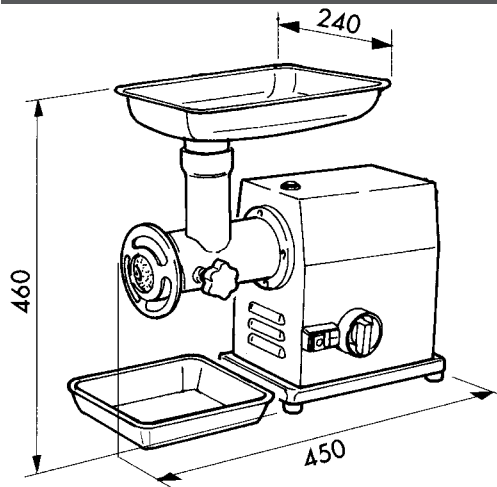

Picadora de carne

Boca: 22. Cuerpo: acero inoxidable. Grupo picador: acero inoxidable. Cuchilla: autoafilante. Interruptor: invertidor de marcha. Potencia: 1,5 HP. Motor: trifásico 220/380V. Producción 250 kg/h

Meat mincer

Outlet: 22. Body: stainless steel. Blade: self-sharpening. Switch: reverse switch. Power: 1,5 HP. Engine: triphase 220/380 V. Production: 250 kg/h.

Hachoirs à viande

Goulot 22. Corps: acier inoxydable. Groupe hachoir: acier inoxydable. Couteau: auto aiguiser. Interrupteur: inverseur. Puissance: 1,5 HP. Moteur: triphasé 220/380 V. Production: 250 kg/h

Picadora de carne

Boca: 22. Cuerpo: acero inoxidable. Grupo picador: acero inoxidable. Cuchilla: autoafilante. Interruptor: invertidor de marcha. Potencia: 1,5 HP. Motor: monofásico 220 V. Producción 250 kg/h

Meat mincer

Outlet: 22. Body: stainless steel. Blade: self-sharpening. Switch: reverse switch. Power: 1,5 HP. Engine: one phase 220 V. Production: 250 kg/h.

Hachoirs à viande

Goulot 22. Corps: acier inoxydable. Groupe hachoir: acier inoxydable. Couteau: auto aiguiser. Interrupteur: inverseur. Puissance: 1,5 HP. Moteur: monophasé 220 V. Production: 250 kg/h

Ref.	Peso Weight Poids
MP-22 MEC-T	30 kg

Ref.	Peso Weight Poids
MP22 MEC-M	30 kg



Despiece / Quartering / Dépeçage

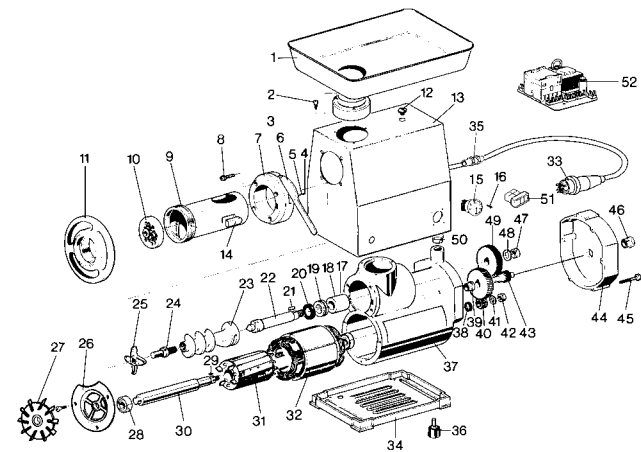

Medidas / Size / Dimensions

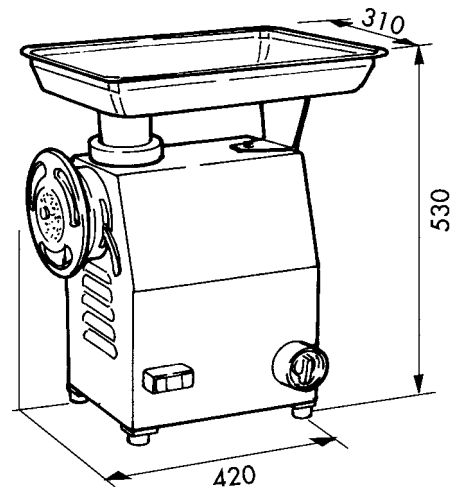

Picadora de carne

Boca: 32. Cuerpo: acero inoxidable. Grupo picador: acero inoxidable. Cuchilla: autoafilante. Interruptor: invertidor de marcha. Potencia 3 HP. Motor trifásico 220/380 V. Producción: 500 kg/h.

Meat mincer

Outlet: 32. Body: stainless steel. Mincer set: stainless steel. Blade: self-sharpening. Revers switch. Power: 3 HP. Engine: three phase 220/380 V. Production: 500 kg/h.

Hachoirs à viande

Goulot: 32. Corps: acier inoxydable. Groupe hachoir: acier inoxydable. Couteau: auto aiguiser. Interrupteur: inverseur. Puissance: 3 HP. Moteur: triphasé 220/380 V. Production: 500 kg

Picadora de carne

Boca: 32. Cuerpo: acero inoxidable. Grupo picador: acero inoxidable. Cuchilla: autoafilante. Interruptor: invertidor de marcha. Potencia 2,5 HP. Motor monofásico 220 V. Producción: 500 kg/h.

Meat mincer

Outlet: 32. Body: stainless steel. Mincer set: stainless steel. Blade: self-sharpening. Revers switch. Power: 2,5 HP. Engine: one phase 220 V. Production: 500 kg/h.

Hachoir à viande

Goulot: 32. Corps: acier inoxydable. Groupe hachoir: acier inoxydable. Couteau: auto aiguiser. Interrupteur: inverseur. Puissance: 2,5 HP. Moteur: monophasé 220 V. Production: 500 kg

Ref.	Peso Weight Poids
MP-32 MEC-T	47 kg

Ref.	Peso Weight Poids
MP-32 MEC-M	47 kg



Despiece / Quartering / Dépeçage

Medidas / Size / Dimensions

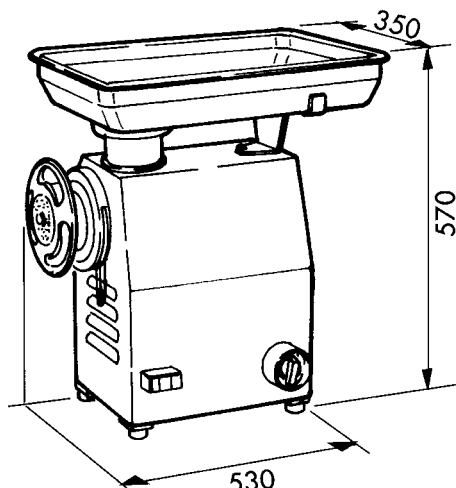
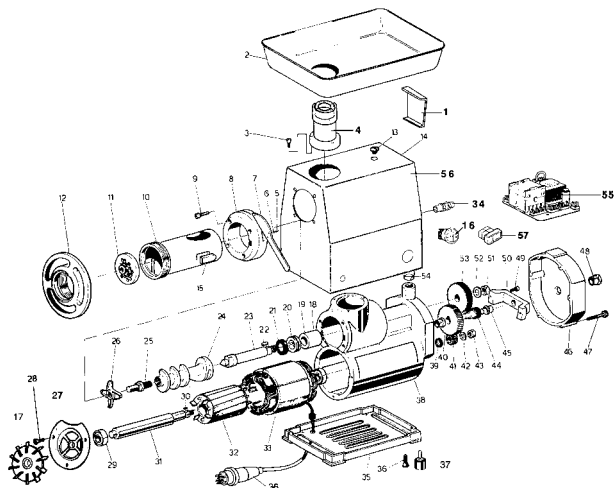

Picadora refrigerada

Boca: 22. Cuerpo: acero inoxidable. Grupo picador: acero inoxidable. Cuchilla: autoafilante. Interruptor: invertidor de marcha. Potencia 1,5 HP. Grupo refrigerador hermético ventilado. Motor trifásico 220/380 V. Peso: 58 kg. Producción: 200 kg/h.

Refrigerated mincer

Outlet: 22. Body: stainless steel. Mincer set: stainless steel. Blade: self-sharpening. Switch: reverse switch. Power: 1,5 HP. Ventilated hermetic refrigeration motor. Motor: three phase 220/380 V. Weight: 58 kg. Production: 200 kg.

Hachoir réfrigéré

Goulot: 22. Corps: acier inoxydable. Couteau: auto aiguiser. Interrupteur: inverseur. Puissance: 1,5 HP. Groupe réfrigérateur hermétique ventilé. Moteur triphasé 220/380 V. Poids: 58 kg. Production: 200 kg/h

Ref.

MP-22RE-T



Despiece / Quartering / Dépeçage

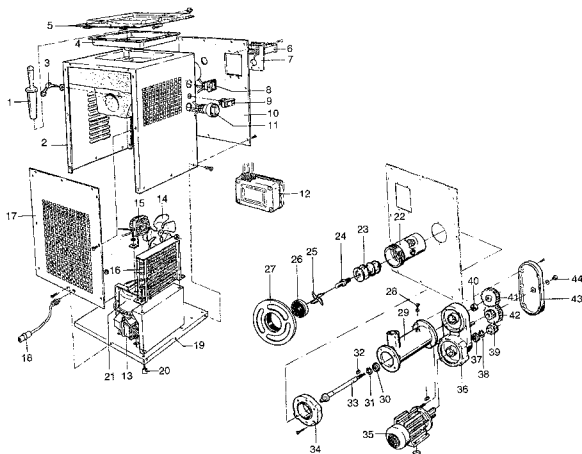

Medidas / Size / Dimensions

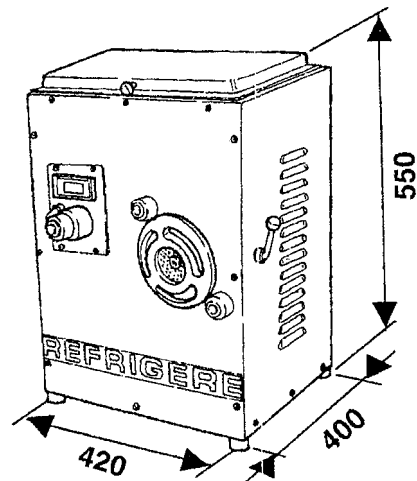

Picadora refrigerada

Boca: 22. Cuerpo: acero inoxidable. Grupo picador: acero inoxidable. Cuchilla: autoafilante. Interruptor: invertidor de marcha. Potencia 3 HP. Grupo refrigerador hermético ventilado. Motor trifásico 220/380 V. Peso: 80 kg. Producción: 300 kg/h.

Refrigerated mincer

Outlet: 22. Body: stainless steel. Mincer set: stainless steel. Blade: self-sharpening. Switch: reverse switch. Power: 3 HP. Veintilated hermetic refrigeration motor. Motor: three phase 220/380 V. Weight: 80 kg. Production: 300 kg.

Hachoir réfrigéré

Goulot: 22. Corps: acier inoxydable. Couteau: auto aiguiser. Interrupteur: inverseur. Puissance: 3 HP. Groupe réfrigérateur hermétique ventilé. Moteur triphasé 220/380 V. Poids: 80 kg. Production: 300 kg/h

Ref.

MP-32RE-T



Despiece / Quartering / Dépeçage

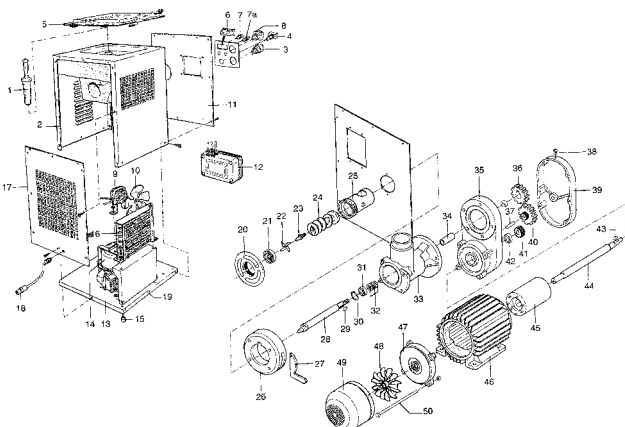

Medidas / Size / Dimensions

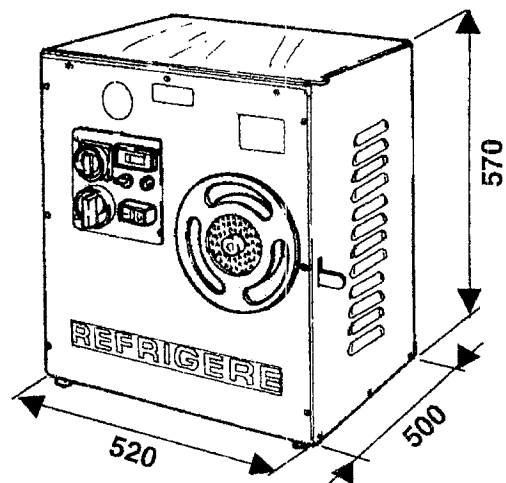



Picadora inox monofase
Boca 8. Cuerpo: acero inoxidable. Grupo picador: acero inoxidable. Cuchilla autoafilante. Motor ventilado. Potencia 0,5 HP. Producción: 70 kg/h.

Stainless steel mincer one phase
 Outlet: 8. Body: stainless steel. Mincer set: stainless steel. Self-sharpening blade. Ventilated engine. Power: 0,5 HP. Production: 70 kg.

Hachoir inox monophase 8 HP 0,5
Goulot: 8. Corps: acier inoxydable. Groupe hachoir: acier inoxydable. Lame: aiguseur. Moteur ventilé. Puissance: 0,5 HP. Production: 70 kg/h.

Despiece / Quartering / Dépeçage

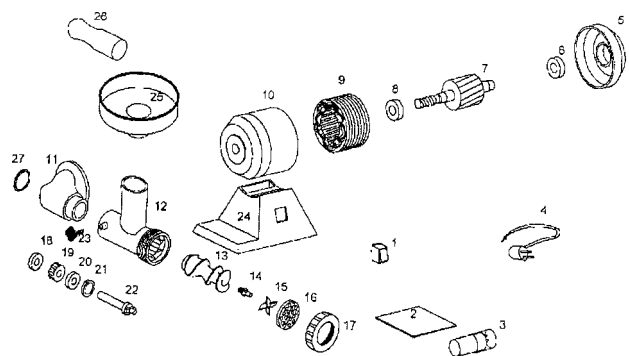

Ref.	Voltaje (V) Voltage (V) Voltage (V)	Medidas Size Dimensions	Peso Weight Poids
MP-8-M	220	27,5 x 25 x 35 cm	9 kg



Cuchilla inox 8

Stainless steel blade 8

Lame inox 8

Ref.

CP-8

CP-8- - Placa inox picadora 8 con 2 chaveteros

CP-8- - Stainless steel mincer plate 8

CP-8- - Plaque inox hachoir 8

Ref.	Diámetro Diameter Diamètre
CP-8-3	Ø 3 mm
CP-8-3,5	Ø 3,5 mm
CP-8-4	Ø 4 mm
CP-8-4,5	Ø 4,5 mm
CP-8-5	Ø 5 mm
CP-8-6	Ø 6 mm
CP-8-7	Ø 7 mm
CP-8-8	Ø 8 mm



Cuchilla inox 12

Stainless steel blade 12

Lame inox 12

Ref.

CP-12

Placa inox 12

Stainless steel plate 12

Plaque inox 12

Ref.	Diámetro Diameter Diamètre
CP-12-3	Ø 3 mm
CP-12- 3,5	Ø 3,5 mm
CP-12-4	Ø 4 mm
CP-12-4,5	Ø 4,5 mm
CP-12-5	Ø 5 mm
CP-12-6	Ø 6 mm
CP-12-7	Ø 7 cm
CP-12-8	Ø 8 mm



2 chaveteros

2 keyways

2 rainures de clavette

Ref.

CP-2C

Placa inox 22

Placa inox 22

Plaque inox 22

Ref.	Diámetro Diameter Diamètre
CP-22-3	Ø 3 mm
CP-22-3,5	Ø 3,5 mm
CP-22-4	Ø 4 mm
CP-22-4,5	Ø 4,5 mm
CP-22-5	Ø 5 mm
CP-22-6	Ø 6 mm
CP-22-7	Ø 7 mm
CP-22-8	Ø 8 mm



Cuchilla inox 22

Stainless steel 22

Lame inox 22

Ref.

CP-22

2 chaveteros

2 keyways

2 rainures de clavette

Ref.

CP-2C





Cuchilla inox 32

Stainless steel blade 32

Lame inox 32

Ref.

CP-32

Placa inox 32

Placa inox 32

Plaque inox 32

Ref.

Diámetro
Diameter
Diamètre

CP-32-3 Ø 3 mm

CP-32-3,5 Ø 3,5 mm

CP-32-4 Ø 4 mm

CP-32-4,5 Ø 4,5 mm

CP-32-5 Ø 5 mm

CP-32-6 Ø 6 mm

CP-32-7 Ø 7 mm

CP-32-8 Ø 8 mm



2 chaveteros

2 keyways

2 rainures de clavette

Ref.

CP-2C

ACCESORIOS PICADORAS-EMBUTIDORAS-AFILADORAS | MINCER-SAUSAGE FILLER-SHARPENER ACCESSORIES | ACCESSOIRES HACHOIRS EMBOUTISSEUSES AIGUISEUSES



Empujador picadoras inyección

Mincer pusher, injection

Poussoir hachoirs injection

Ref.	Diámetro Diameter Diamètre	Largo Long Longueur
A-35-11	Ø 5 cm	11 cm
A-35-13	Ø 5 cm	13 cm
A-35-15	Ø 5 cm	15 cm
A-35-26	Ø 4,5 cm	12,5 cm



Empujador picadoras polietileno

Polyethylene mincer pusher

Poussoir hachoirs polyéthylène

Ref.	Diámetro Diameter Diamètre	Largo Long Longueur
A-36-11	Ø 5 cm	11 cm
A-36-13	Ø 5 cm	13 cm
A-36-15	Ø 5 cm	15 cm



Cintas de sierra para carne
Características 16 x 0,4 mm. Tamaño del diente 7 mm. Corte de carne fresca sin hueso o pequeños huesos

Meat band saws
 Features 16 x 0.4 mm. Tooth size 7 mm. Cut of fresh meat without bone or small bones

Scies à ruban de viande
Caractéristiques 16 x 0.4 mm. Taille de dent 7 mm. Couper de la viande fraîche sans os ou petits os

Ref.	Largo Long Longueur	Unidades Units Unités
SCA-1600	1600 mm	4
SCA-1740	1740 mm	4
SCA-1750	1750 mm	4
SCA-1985	1985 mm	4
SCA-2120	2120 mm	4
SCA-2340	2340 mm	4
SCA-2520	2520 mm	4
SCA-2930	2930 mm	4



Cintas de sierra para hueso
Características 16 x 0,50 mm. Tamaño del diente 6,35 mm (4 dientes pulgada). Corte de hueso

Bone saw bands
 Characteristics 16 x 0,50 mm. Tooth size 7 mm (4 teeth inch). Bone cutting

Scies à ruban pour l'os
Caractéristiques 16 x 0,50 mm. Taille de dent 7 mm (4 dents pouces). Coupe d'os

Ref.	Largo Long Longueur	Unidades Units Unités
SHU-1600	1600 mm	4
SHU-1740	1740 mm	4
SHU-1750	1750 mm	4
SHU-1985	1985 mm	4
SHU-2120	2120 mm	4
SHU-2340	2340 mm	4
SHU-2520	2520 mm	4
SHU-2930	2930 mm	4

Cintas de sierra para congelados
Características 16 x 0,56 mm. Tamaño diente 8,46 mm (3 dientes/pulgada). Corte de carne, pescado y congelados

Saw bands for frozen
 Characteristics 16 x 0.56 mm. Tooth size 8.46 mm (3 teeth / inch). Cut of meat, fish and frozen

Rubans de scie pour congelés
Caractéristiques 16 x 0,56 mm. Taille de denture 8.46 mm (3 dents / pouce). Coupe de viande, poisson et congelé

Ref.	Largo Long Longueur	Unidades Units Unités
SCO-1600	1600 mm	4
SCO-1740	1740 mm	4
SCO-1750	1750 mm	4
SCO-1985	1985 mm	4
SCO-2120	2120 mm	4
SCO-2340	2340 mm	4
SCO-2520	2520 mm	4
SCO-2930	2930 mm	4



Características técnicas Technical specifications Caractéristiques techniques	MC-E300	MC-E350	MC-M350
Cuchilla alemana German blade Lame allemande	300	350	350
Potencia Power Pissance	0.37 KW / 0.5 HP	0.37 KW / 0.5 HP	0.37 KW / 0.5 HP
Voltaje Voltage Voltage	230 V	230 V	230 V
Espesor corte Cutting thickness Dimensions ext.	0-15	0-15	0-24
Medidas exteriores Exterior measurement Mesures extérieures	519 x 620 x 450	560 x 695 x 520	590 x 840 x 550
Medidas base apoyo A-L Base size Dimensions base	360 x 480	390 x 540	480 x 605
Peso Weight Poids	30 kg	38 kg	40 kg
Afilador incorporado Sharpener Aiguiseur	SI / YES / OUI	SI / YES / OUI	SI / YES / OUI
Transmisión Transmission Transmission	CORREA / BELT / COURROIE	CORREA / BELT / COURROIE	DIRECTA
Aluminio anodizado anticorrosivo Aluminium anodized anticorrosive Aluminium anodisé anticorrosif	SI / YES / OUI	SI / YES / OUI	SI / YES / OUI
Capacidad corte (grueso) Slicing capacity (thickness) Capacité de coupe (épaisseur)	170 x 250	200 x 280	185 x 300
Precio P.V.P Retail price Prix conseillé	2305,00 €	2651,00 €	3888,00 €



MC-E300
MC-E350



MC-M350

Características técnicas Technical specifications Caractéristiques techniques	MC-220-AF	MC-250-C	MC-300-E	MC-350-I
Cuchilla alemana German blade Lame allemande	220	250	300	350
Potencia Power Pussance	186 W / 0,25 HP	225 W / 0,30 HP	260 W / 0,35 HP	372 W / 0,50 HP
Voltaje Voltage Voltage	230 V	230 V	230 V	230 V
Espesor corte Cutting thickness Dimensions ext.	0-15	0-16	0-16	0-16
Medidas exteriores Exterior measurement Mesures extérieures	405 x 580 x 340	425 x 620 x 370	595 x 650 x 440	585 x 890 x 480
Medidas base apoyo A-L Base size Dimensions base	280 x 415	390 x 440	240 x 465	415 x 580
Peso Weight Poids	13,5 kg	15,5 kg	23 kg	36 kg
Afilador incorporado Sharpener Aiguiseur	SI / YES / OUI	SI / YES / OUI	SI / YES / OUI	SI / YES / OUI
Transmisión Transmission Transmission	CORREA / BELT / COURROIE	CORREA / BELT / COURROIE	CORREA / BELT / COURROIE	CORREA / BELT / COURROIE
Aluminio anodizado anticorrosivo Aluminium anodized anticorrosive Aluminium anodisé anticorrosif	SI / YES / OUI	SI / YES / OUI	SI / YES / OUI	SI / YES / OUI
Capacidad corte (grueso) Slicing capacity (thickness) Capacité de coupe (épaisseur)	160 x 190	190 x 220	220 x 220	360 x 310
Precio P.V.P Retail price Prix conseillé	804,00 €	960,00 €	1398,00 €	2270,00 €



MC-220-AF



MC-250-C



MC-300-E



MC-350-I



**Cortadora fiambres manual 250. Espesor corte 0+2.
Capacidad corte (Grueso) de 150 x 185 mm. Posición sobremesa.**

Cold cuts cutter manual 250. Cut thickness 0+2.
Cutting capacity (thickness) 150 x 185 mm. Position desktop.

*Coupante charcuterie manual 250. Épaisseur de coupe 0+2.
Capacité coupure (épaisseur) 150 x 185 mm. Position sur table.*

Ref.

MC-250-VOL



**Cortadora fiambres manual 300. Espesor corte 0+2.
Capacidad corte (Grueso) de 190 x 230 mm. Posición sobremesa.**

Cold cuts cutter manual 300. Cut thickness 0+2.
Cutting capacity (thickness) 190 x 230 mm. Position desktop.

*Coupante charcuterie manual 300. Épaisseur de coupe 0+2.
Capacité coupure (épaisseur) 190 x 230 mm. Position sur table.*

Ref.

MC-300-VOL



Soporte columna para MC-250/300-VOL

Column support for MC-250/300-VOL

Support colonne pour MC-250/300-VOL

Ref.

MC-2530



Ralladora mozzarella

Cuerpo: acero inoxidable. Potencia: 0,35 HP. Motor monofásico 220 V. Peso 14 kg. Producción: 50 kg/h.

Mozzarella grater
Body: stainless steel. Power: 0,35 HP. Motor: one phase 220 V.
Weight : 14 kg. Production: 50 Kg/h.

Râpe à fromage

Corps: acier inoxydable. Puissance 0,35 HP. Moteur: monophasé 220 V. Poids: 14 kg. Production: 50 kg/h.

Ref.

MPQ-MOZZARELLA



Campana agujero 2 mm. para queso en hilo

Cone shaped grater with 2 mm holes for shredded cheese

Cloche trou 2 mm pour fromage filé

Ref.

MPQ-MOZ-15



Despiece / Quartering / Dépeçage

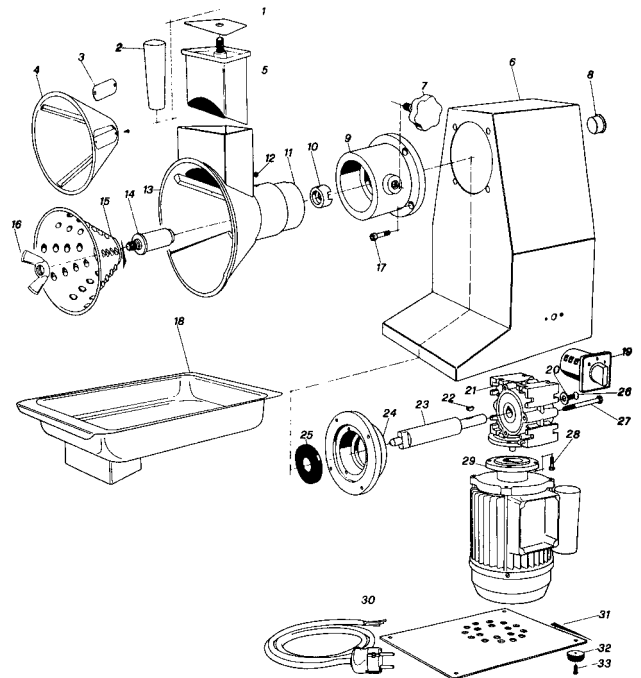

Ralladora motor estanco HP 0,5, monofase 220 V. Potencia 600 W / Producción 50 kg/h

Grater protected engine HP 0,5, one phase 220 V. Power 600 W / Production 50 kg/h

Râpe moteur protégé HP 0,5, monophasé 220 V. Puissance 600 W / Production 50 kg/h

Incluye disco 3 m/m

Includes 3m/m disc

Comprend un disque de 3 m/m

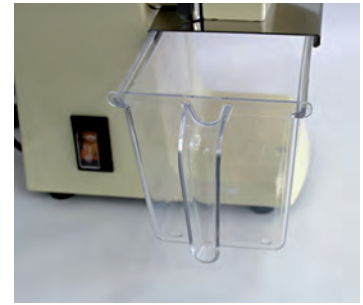

Ref.	Medidas Size Dimensions	Peso Weight Poids
MPQ-02	42 x 25 x 36 cm	14,5 kg



Disco parmesano para ref. MPQ-02

Parmesan disk for ref. MPQ-02

Disque parmesan pour réf. MPQ-02

Ref.
DR-0

Disco agujero para ref. MPQ-02

Hole disk for ref. MPQ-02

Disque trou pour réf MPQ-02

Ref.	Tipo Type Type
DR-2	2 mm
DR-3	3 mm
DR-4	4 mm
DR-6	6 mm
DR-8	8 mm

Disco hielo para ref. MPQ-02

Ice disk for ref. MPQ-02

Disque glace pour réf. MPQ-02

Ref.
DRH



EXPRIMIDOR CÍTRICOS | CITRUS JUICER | PRESSE-CITRON

Exprimidor cítricos Santos nº 10. Potencia 230 W. Producción 30 L/H

Citrus juicer Santos nº 10. Power 230 W. Production 30 L/H

Presse-citron Santos nº 10. Puissance 230 W. Production 30 L/H

Ref.	Medidas Size Dimensions	Peso Weight Poids
MSE-10	30 x 20 x 38 cm	9,5 kg

Máquina ralladora-cortadora multifunción

Cuerpo: acero inoxidable y aleación especial. Potencia: HP 0,75. Motor: trifásico 230/380 V. Peso 20 kg. Producción: 150-300 kg/h

Multi purpose grater-slicer machine

Body: stainless steel with special alloy. Power: 0,75 HP. Engine: three phase 230/380 V. Weight: 20 Kg. Production: 150-300 kg/h

Machine à râpe-découpoir multifonction

Corps: acier inoxydable et aliage spécial. Puissance: 0,75 HP.

Moteur: triphasé 230-380 V. Poids: 20 kg. Production : 150-300 kg/h

Ref.

MPQV-5-T

Máquina ralladora-cortadora multifunción

Cuerpo: acero inoxidable y aleación especial. Potencia: HP 0,75. Motor: monofásico 230 V. Peso 20 kg. Producción: 150-300 kg/h

Multi purpose grater-slicer machine

Body: stainless steel with special alloy. Power: 0,75 HP. Engine: One phase 230 V. Weight: 20 Kg. Production: 150/300 kg/h

Machine à râpe-découpoir multifonction

Corps: acier inoxydable et aliage spécial. Puissance: 0,75 HP.

Moteur: monophasé 230V. Poids: 20 kg. Production : 150-300 kg/h

Ref.

MPQV-5-M



Despiece / Quartering / Dépeçage

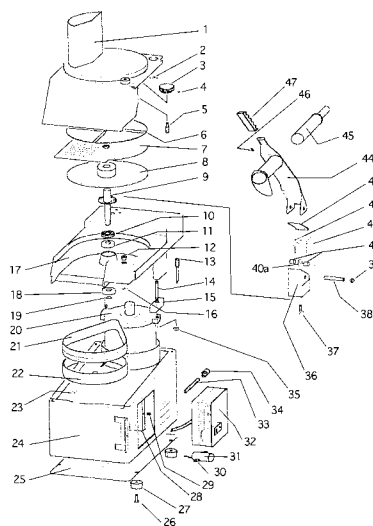

Medidas / Size / Dimensions

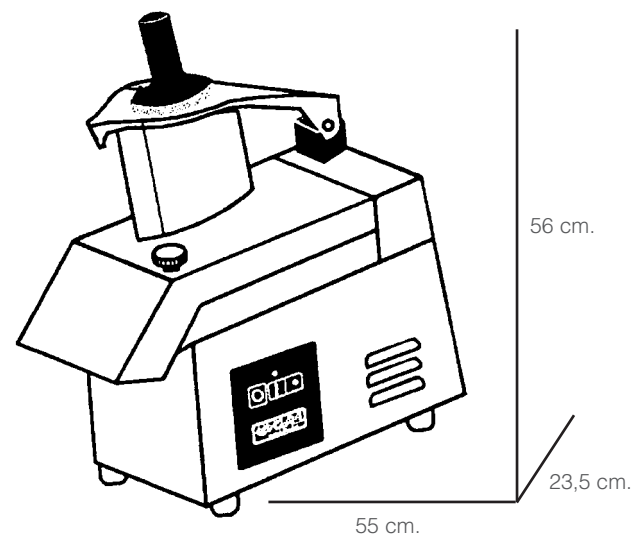

DISCOS RALLADORES HILO-POLVO PARA QUESO, VERDURAS, PAN Y FRUTOS SECOS | STRING-FINE SHRED GRATER DISKS FOR CHEESE, VEGETABLES, BREAD CRUMBS AND NUTS | DISQUES À RÂPER FIL POUVRE POUR FROMAGE, LÉGUMES, PAIN ET FRUITS SECS



Disco para hilo

Disk for slices

Disque pour rondelles

Ref.	Tipo Type Type
DZ-2	2 mm
DZ-3	3 mm
DZ-4	4 mm
DZ-7	7 mm

Disco para polvo

Fine shred disk

Disque pour poudre

Ref.

DV

DISCO PARA CORTE EN RODAJAS | SLICING DISKS | DISQUES POUR COUPER EN RONDELLES



Disco para rodajas

Disk for slice

Disque pour rondelles

Ref.	Tipo Type Type
DE-1	1 mm
DE-2	2 mm
DE-3	3 mm
DE-4	4 mm



Disco para rodajas

Disk for slice

Disque pour rondelles

Ref.	Tipo Type Type
DE-6	6 mm
DE-8	8 mm
DE-10	10 mm
DE-14	14 mm



Accesorios rejilla a tiras (patatas fritas)

Strip slicer accessories (fried chips)

Accessoires grille en lamelles (frites)

Ref.	Tipo Type Type
DB-6	6 mm (DE-6)
DB-8	8 mm (DE-8)
DB-10	10 mm (DE-10)



Accesorios rejilla cubos

Dicing accessories

Accessoires grille dés

Ref.	Tipo Type Type
DD-8	8 x 8 mm (DE-8)
DD-10	10 x 10 (DE-10)
DD-20	20 x 20 mm (DE-14)

DISCO CURVO CORTE BLANDO EN RODAJAS TOMATES, NARANJA, LIMÓN, PLÁTANO, ETC | CURVED DISK, SLFT CUT IN SLICES, TOMATOES, ORANGE, LEMON, BANANA, ETC. | DISQUE COURBE DÉCOUPE TENDRE EN RONDELLES, TOMATES, ORANGE, CITRON, BANANE, ETC.



Disco curvado corte blando

Curved disk soft cut

Disque courbe découpe tendre

Ref.	Tipo Type Type
DS-1	1 mm
DS-2	2mm
DE-5	5 mm



Disco para rodajas onduladas

Disk for wavy slices

Disque pour rondelles ondulées

Ref.	Diámetro Diameter Diamètre
DH-2,5	Ø 2,5 mm
DH-4	Ø 4 mm
DH-6	Ø 6 mm
DH-8	Ø 8 mm
DH-10	Ø 10 mm

DISCO DE CORTE REGULABLE | ADJUSTABLE SLICER DISK | DISQUE DÉCOUPE RÉGLABLE



Disco corte en rodajas regulable de 1 a 8 mm

Kisk for adjustable slices 1 to 8 mm

Disque pour rondelles réglable de 1 à 8 mm

Ref.

DX-1

ACCESORIOS DISCOS | DISKS ACCESSORIES | DISQUES ACCESSOIRES

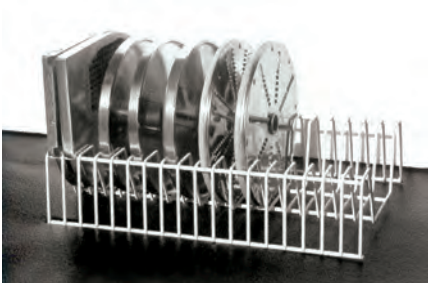

Soporte portadiscos

Disk-rack

Support porte-disques

Ref.	Medidas Size Dimensions
DA-18	39,5 x 25,6 x 10 cm

Disco expulsor para ref. MPQV-5

Disk remover for ref MPQV-5

Disque expulseur pour réf. MPQV-5

Ref.

DA-1



Cutter 3 L
Cuerpo: acero inoxidable. Potencia : 480W. Motor: monofásico 230 V. Velocidad variable: 900-2200 rpm. Peso: 11 kg. Dimensiones cubeta: 18 Ø x 10,5 cm altura. Incluye cuchilla lisa.

Cutter 3 L
 Body: stainless steel. Power 480W. Engine: one phase 230 V. Variable speed: 900/2200 rpm. Weight: 11 kg. Bowl sizes: 18 Ø x 10,5 cm height. Includes smooth blade

Cutter 3 L
 Corps: acier inoxydable. Puissance 480W. Moteur: monophasé 230 V. Vitesse variable: 900/2200 rpm. Poids: 11 kg. Dimensions bac: 18 Ø x 10,5 cm hauteur. Comprend lame lisse.

Ref.

MC-3

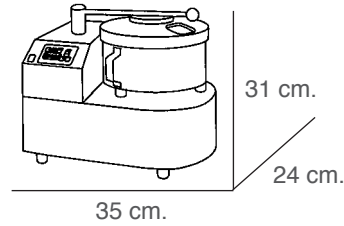

MC-CL-X - Cuchilla lisa afilada para triturar

MC-CL-X - Smooth blade sharpened for grinding

MC-CL-X - Lame lisse aiguisée pour triturer



MC-CD-X - Cuchilla dentada para triturar

MC-CD-X - Tooth blade for grinding

MC-CD-X - Lame dentelée pour triturer



MC-CP-X - Cuchilla perforada para batir y amasar

MC-CP-X - Perforated blade for mixing and kneading

MC-CP-X - Lame perforée pour battre et pétrir

Ref.	Tipo Type Type
MC-CL-3	MC-3
MC-CL-5	MC-5, MC-8

Ref.	Tipo Type Type
MC-CD-3	MC-3
MC-CD-5	MC-5, MC-8

Ref.	Tipo Type Type
MC-CP-3	MC-3
MC-CP-5	MC-5, MC-8



Puré de tomate / Purée de tomate / Purée de tomate: 60 seg.

Mayonesa / Mayonnaise / Purée de tomate: 130 seg.

Perejil, ajo, cebolla, pimiento triturado / Parsley, garlic, onion pepper grinded / Persil, ail, oignon et le poivron moulu: 15 seg.

Pan rallado / Breadcrumbs / Chapelure: 60 seg.

Chocolate / Chocolate / Chocolat : 60 seg.



Frutos secos triturados / Dried fruits grinded / Fruits secs broyés: 20 seg.

Mozzarella para pizza / Pizza mozzarella / Mozzarella pour pizza: 10 seg.

Carne triturada / Grinded meat / Viande broyée: 10 seg.

Amasijos tiernos para pastelería / Bakery mixture / Pâtisserie: 60 seg.

Puré de verduras / Purée de légumes / Purée de légumes: 5 seg.

Cutter 5 L

Cuerpo: acero inoxidable. Potencia : 960W. Motor: monofásico 230 V. Velocidad variable: 900-2200 rpm. Peso: 18 kg. Dimensiones cubeta: 24 Ø x 12 cm altura. Incluye cuchilla lisa.

Cutter 5 L

Body: stainless steel. Power 960W. Engine: one phase 230 V. Variable speed: 900/2200 rpm. Weight: 18 kg. Bowl sizes: 24 Ø x 12 cm height. Includes smooth blade

Cutter 5 L

Corps: acier inoxydable. Puissance 960W. Moteur: monophasé 230 V. Vitesse variable: 900/2200 rpm. Poids: 18 kg. Dimensions bac: 24 Ø x 12 cm hauteur. Comprend lame lisse.

Ref.

MC-5

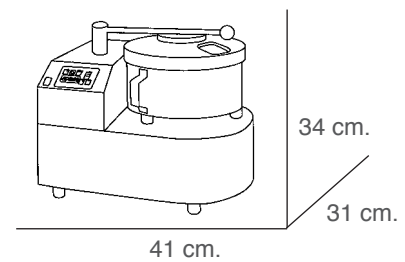
**Cutter 8 L**

Cuerpo: acero inoxidable. Potencia : 960W. Motor: monofásico 230 V. Velocidad variable: 900-2200 rpm. Peso: 19 kg. Dimensiones cubeta: 24 Ø x 18 cm altura. Incluye cuchilla lisa.

Cutter 8 L

Body: stainless steel. Power 960W. Engine: one phase 230 V. Variable speed: 900/2200 rpm. Weight: 19 kg. Bowl sizes: 24 Ø x 18 cm height. Includes smooth blade

Cutter 8 L

Corps: acier inoxydable. Puissance 960W. Moteur: monophasé 230 V. Vitesse variable: 900/2200 rpm. Poids: 18 kg. Dimensions bac: 24 Ø x 12 cm hauteur. Comprend lame lisse.

Ref.

MC-8

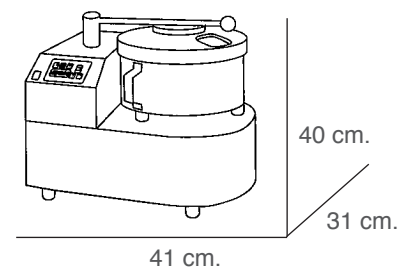

Máquina enternecedor de carne
Cuchillas desmontables, fácil limpieza.

Potencia: 0,50 HP. Cuchillas acero-inox con 180 microcortes por Dm². Motor monofásico 220 V.

Meat tenderizer
Detachable blades, easy cleaning.

Power: 0,50 HP. Stainless steel blades with 180 micro cuts per Dm².
Motor: one phase 220 V.

Attendrisseur viande
Couteaux séparables, nettoyage facile.

Puissance: 0,50 HP. Couteaux acier inox avec 180 micro entailles par Dm². moteur: monophasé 220 V.



Ref.	Medidas Size Dimensions	Peso Weight Poids
MPE-18	41 x 19 x 40 cm	17 kg



Molino pimienta
Potencia: 1 HP. Producción: 12 kg/h

Pepper mill
 Power: 1 HP. Production: 12 kg/h

Moulin à poivre
Puissance: 1 HP. Production: 12 kg/h



Ref.	Medidas Size Dimensions	Peso Weight Poids
MPP-10	22 x 34 x 61 cm	12 kg



AFILADORA | SHARPENER | AIGUISEUR

Afilador mini
Afilado: 2 piedras: 1 afilado y 1 pulido

Mini sharpener
 Sharpening: 2 stones: 1 sharp. & 1 polish

Aiguiser mini
Aiguisage: 2 pierres: 1 aiguisée et 1 polie.



Ref.	Medidas Size Dimensions	Voltaje (V) Voltage (V) Voltage (V)
A-198	22 x 9 x 8 cm	220

Juego 2 piedras con eje para ref. A-198

Stone set for ref. A-198

Ensemble 2 pierres pour réf. A-198



Ref.
A-198-1



0 3 AFILADORA | SHARPENER | AIGUISEUR

Máquina afilar banda

Potencia: 0,35 HP. Revoluciones: 2800 rpm. Motor: monofásico 220 V.

Band-sharpening machine

Power: 0.35 HP. Revoluciones: 2800 rpm. Engine: One phase 220 V.

Machine à aiguiser bande

Puissance: 0,35 HP. Révolutions: 2800 rpm. Moteur: Monophasé 220 V.

Ref.	Medidas Size Dimensions	Voltaje (V) Voltage (V) Voltage (V)	Peso Weight Poids
A-200	33 x 28 x 40 cm	220	9 kg

Afilar / Sharpen / Aiguiser



Pulir / Polish / Polir



Banda afilar para ref. A-200

Sharpening band for ref. A-200

Bande aiguiser pour réf. A-200

Ref.

A-200-13X Circonio

A-200-13

Disco pulir para ref. A-200

Polishing disk for ref. A-200

Disque polir pour réf. A-200

Ref.

A-200-33

Despiece / Quartering / Dépeçage

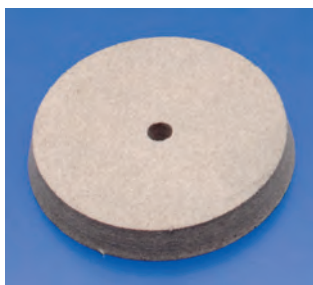
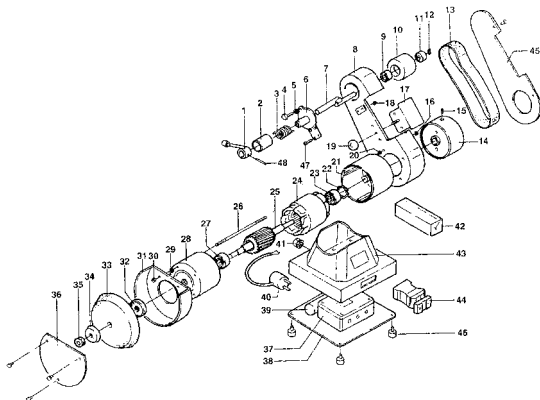

0

4

Maquinas retractilar, Film, Dispensadores de film, Dispensador papel aluminio, Soldadoras de bolsas, Máquina sellar, Máquina vacío, Parrilla envasadora, Bolsas vacío, Termoselladora.

Wrapping machines, Film, Film dispensers, Aluminium foil dispenser, Bag sealer, Sealer machine, Vacuum machine, Packaging grill, Vacuum bags, Thermo sealer.

Machine à retractiler, Film, Dispensateurs film, Dispensateur papier aluminium, Scelleuse de sacs, Machine à sceller, Machine vide, Grill à sceller, Sacs sous vide, Thermo machine.

87-100



Máquina retractilar, acero-inox
Con placa de calor. Interruptor para placa calor ON/OFF. Interruptor para resistencia corte ON/OFF.

Wrapping machine, stainless steel
 Featuring heat plate. Heat plate ON/OFF switch.ON/OFF switch for cut resistance.

Machine à rétractiler, acier-inox
Avec plaque de chauffage. Interrupteur pour plaque de chauffage ON/OFF. Interrupteur pour résistance découpe ON/OFF.

Ref.	Medidas Size Dimensions	Resistencia corte Cut resistance Résistance à la découpe	Bobina film Film roll Bobine film	Voltaje (V) Voltage (V) Voltage (V)
MR-4-ECO	59 x 48,5 x 13,5 cm	46 cm	MR-40/45	220
MR-4-500-ECO	59 x 52 x 13,5 cm	50 cm	MR-40/45/47	220



Máquina retractilar, acero-inox
Con placa de calor. Interruptor para placa calor ON/OFF. Interruptor para resistencia corte ON/OFF.

Wrapping machine, stainless steel
 Featuring heat plate. Heat plate ON/OFF switch.ON/OFF switch for cut resistance.

Machine à rétractiler, acier-inox
Avec plaque de chauffage. Interrupteur pour plaque de chauffage ON/OFF. Interrupteur pour résistance découpe ON/OFF.

Ref.	Medidas Size Dimensions	Resistencia corte Cut resistance Résistance à la découpe	Voltaje (V) Voltage (V) Voltage (V)	Bobina film Film roll Bobine film
MR-4	59 x 48,5 x 13,5 cm	45 cm	220	MR-40/45
MR-4-500	59 x 52 x 13,5 cm	50 cm	220	MR-40/45/47
MR-4-600	65 x 62 x 13,4 cm	60 cm	220	MR-40/45/46/47



Máquina retractilar
Con placa de calor. Interruptor para placa calor ON/OFF. Interruptor para resistencia corte ON/OFF. Ideal para espacios reducidos al llevar la bobina de film en su interior.

Wrapping machine
 Featuring heat plate. Heat plate ON/OFF switch.ON/OFF switch for cut resistance. Ideal for small spaces because it incorporates the film roll inside.

Machine à rétractiler
Avec plaque de chauffage. Interrupteur pour plaque de chauffage ON/Of. Interrupteur pur résistance découpe ON/OFF. Idéal pour les petits espaces car il intègre le rouleau de film à l'intérieur.

Ref.	Medidas Size Dimensions	Bobina film Film roll Bobine film	Resistencia corte Cut resistance Résistance à la découpe
MR-1	48 x 45 x 19 cm	MR-20/30	45 cm
MR-1-ECO	48 x 45 x 19 cm	MR-20/30	46 cm



Máquina retractor
Sin placa de calor. Interruptor ON/OFF.

Wrapping machine
Without heat plate. Heat plate ON/OFF.

Machine à rétractiler
Sans plaque de chauffage. Interrupteur pour plaque de chauffage ON/OFF.

Ref.	Medidas Size Dimensions	Resistencia corte Cut resistance Résistance à la découpe	Bobina film Film roll Bobine film	Voltaje (V) Voltage (V) Voltage (V)
MR-2	48,5 x 27 x 17,5 cm	45 cm	MR-20	220



Máquina retractor
Sin placa de calor. Interruptor ON/OFF.

Wrapping machine
Without heat plate. Heat plate ON/OFF switch. **BOBINAS FILM | FILM ROLLS | BOBINES FILM**

Machine à rétractiler
Sans plaque de chauffage. Interrupteur pour plaque de chauffage ON/OFF.

Ref.	Medidas Size Dimensions	Resistencia corte Cut resistance Résistance à la découpe	Bobina film Film roll Bobine film	Voltaje (V) Voltage (V) Voltage (V)
MR-3	34,5 x 27 x 17,5 cm	30 cm	MR-30	220



Bobinas de film

Film rolls

Bobines film

Ref.	Medidas Size Dimensions
MR-20	40 x 500 cm
MR-30	30 x 500 cm
MR-40	40 x 1500 cm
MR-45	45 x 1500 cm
MR-47	50 x 1500 cm
MR-46	60 x 1500 cm
MR-49	90 x 1500 cm
MR-50	30 x 300 cm
MR-60	45 x 300 cm



Dispensador inox con cuchilla
Posición sobre mesa ó pared.

Stainless steel dispenser with cutter
Free standing or attached to wall.

Distributeur inox avec lame
Pose sur table ou mur.

Ref.	Medidas Size Dimensions	Bobina film Film roll Bobine film
MR-10	36 x 12,5 x 9 cm	MR-50
MR-11	50 x 12,5 x 9 cm	MR-60
MR-10-1	Cuchilla para / Blade for <i>/ Lame pour</i>	
		MR-10, 11, 12, 13, 14

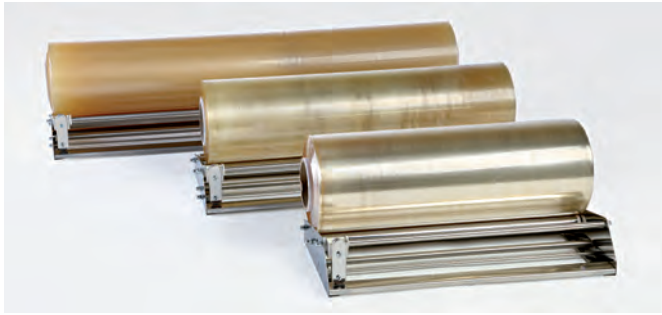

Dispensador inox con cuchilla
Posición sobre mesa.

Stainless steel dispenser with cutter
Free standing or attached.

Distributeur inox avec lame
Pose sur table.

Ref.	Medidas Size Dimensions	Bobina film Film roll Bobine film
MR-12	50 x 22 x 9 cm	MR-45
MR-13	63 x 22 x 9 cm	MR-46/47
MR-14	95 x 22 x 9 cm	MR-49

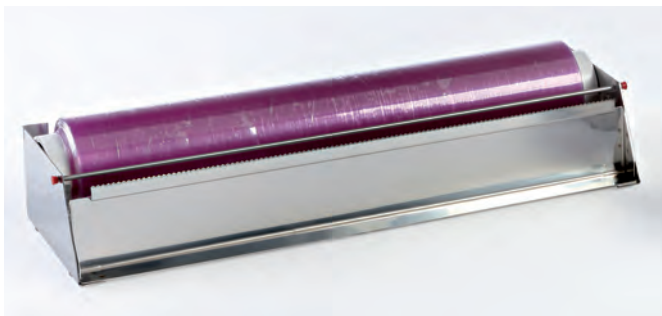

Dispensador acero inox
Posición sobre mesa ó pared.

Stainless steel dispenser
Free standing or attached to wall.

Distributeur acier inox
Pose sur table ou mur.

Ref.	Medidas Size Dimensions	Bobina film Film roll Bobine film
MRI-5	34 x 16 x 9 cm	MR-50
MRI-6	49 x 16 x 9 cm	MR-60

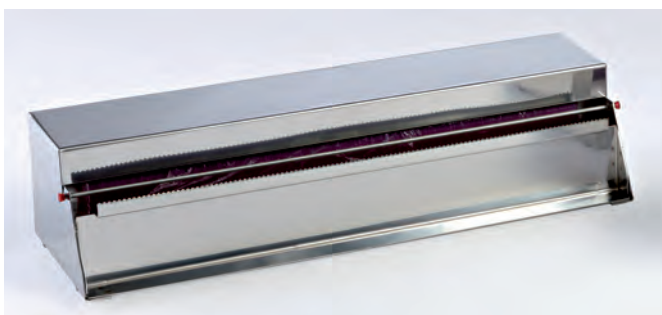

Dispensador con tapa acero-inox
Posición sobre mesa ó pared.

Dispenser with stainless steel top
Free standing or attached to wall.

Distributeur avec couvercle acier inox
Pose sur table ou mur.

Ref.	Medidas Size Dimensions	Bobina film Film roll Bobine film
MRIT-5	34 x 16 x 12 cm	MR-50
MRIT-6	46 x 16 x 12 cm	MR-60

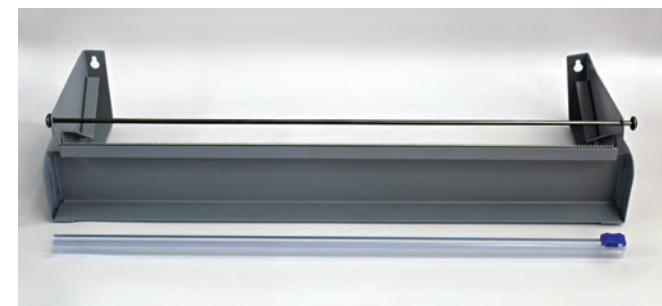

MR-5_6 - Dispensador metálico
Con kit de cuchilla para corte.

MR-5_6 - Metal dispenser
With cutting blade kit.

MR-5_6 - Dispensador de metálico
Avec coupe kit de lame.

Ref.	Medidas Size Dimensions	Bobina film Film roll Bobine film
MR-5	34 x 16 x 9 cm	MR-50
MR-6	49 x 16 x 9 cm	MR-60



Dispensador inox papel aluminio 45 cm inox

Stainless steel dispenser for 45 cm aluminium

Dispensateur inox pour aluminium de 45 cm

Ref.
MR-9

Papel aluminio

Aluminium foil

Papier aluminium

Ref.	Medidas Size Dimensions
MR-80	29 x 300 cm
MR-90	40 x 300 cm



SOLDADORAS DE BOLSAS | BAG SEALER | SCELLEUSE DE SACS

Soldadora de bolsas

Con regulador de temperatura, posición sobremesa.

Bag sealer

With temperature regulator, positioning free standing.

Scelleuse de sacs

Régulateur de température, position surtable.

Ref.	Maximum seal Maximum seal Maximum seal	Voltaje (V) Voltage (V) Voltage (V)
SB-200	20 cm	220
SB-300	30 cm	220
SB-400	40 cm	220
SB-500	50 cm	220



Soldadora de bolsas

Con regulador de temperatura.

Bag sealer

With temperature regulator.

Scelleuse de sacs

Régulateur de température.

Ref.	Maximum seal Maximum seal Maximum seal	Voltaje (V) Voltage (V) Voltage (V)
SB-600	60 cm	220
SB-1000	100 cm	220



Soldadora de bolsas

Con regulador de temperatura, posición sobremesa.

Bag sealer

With temperature regulator, positioning free standing.

Scelleuse de sacs

Régulateur de température, position surtable.

Ref.	Maximum seal Maximum seal Maximum seal	Voltaje (V) Voltage (V) Voltage (V)
SB-400-ECO	40 cm	220
SB-500-ECO	50 cm	220

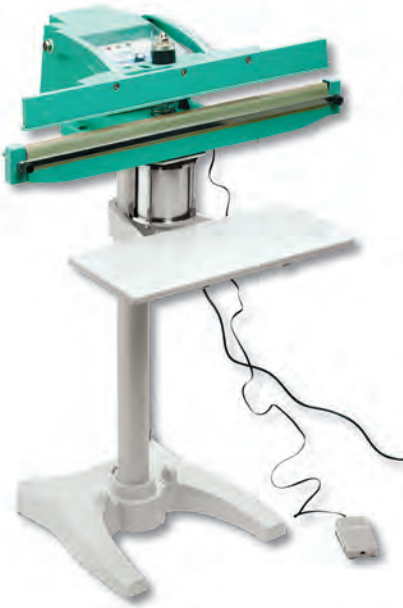

Soldador semiautomático con pedal
Pedal eléctrico, ancho sellado de 5 mm.

Semi-automatic sealer with pedal
 Electric pedal, seal wide a 5 mm.

Scelleuse semi automatique avec pédale
Pédale électrique, largeur scellée 5 mm.

Ref.	Medidas Size Dimensions	Maximum seal Maximum seal Maximum seal	Voltaje (V) Voltage (V) Voltage (V)
SBPA-450	53,5 x 38 x 88 cm	45 cm	220
SBPA-600	68 x 38 x 88 cm	60 cm	220

MÁQUINA SELLAR | SEALER MACHINE | MACHINE À SCELLER



Máquina selladora en "U"
Regulador de temperatura, acero-inox - epoxi blanco, posición sobre mesa.

U- sealer machine
 Temperature regulator, stainless steel, positioning free standing.

Machine à sceller en forme de U
Régulateur de température, acier inox époxy blanc, pose sur table.

Ref.	Medidas Size Dimensions	Voltaje (V) Voltage (V) Voltage (V)
MR-15	35 x 33 x 35 cm	220



Soldadora de bolsas magnético
Soporte pared opcional. Especial para entrada hipermercados.
Barra de soldadura de 50 cm.

Magnetic bag sealer
 Optional wall bracket. Special for supermarkets entrance. Welding rod 50 cm.

Scelleuse de sacs magnétique
Support mural optionnel. Spécial pour l'entrée des hypermarchés.
Baguette de soudure 50 cm.

Ref.	Voltaje (V) Voltage (V) Voltage (V)	Maximum seal Maximum seal Maximum seal
SBM-500	220 V	500 mm

Mesa de trabajo colgada a la pared

Work table hanging on the wall

Table de travail suspendue au mur

Ref.
SBM-505



**Máquina envasadora al vacío
Estructura + cuba en acero inox.**

6 programas memoria, con pantalla digital

Vacuum packaging machine
Stainless steel structure + cuba.

Memory 6 programs, with digital display

*Machine d'emballage sous vide
Estructura + Cuba en acier inoxydable.*

Mémoire 6 programmes, avec affichage numérique

Ref.	Dimensiones máquina Machine size Dimensions machine	Dimensiones cámara Chamber size Dimensions chambre	Soldadura Seal Soudure	Peso Weight Poids	Bomba vacío Vacuum pump Pompe à vide	Voltaje (V) Voltage (V) Voltage (V)
MV-10	410 x 460 x 460 mm	310 x 350 x 190 mm	300 mm x 5 mm	38 kg	10 M3/h	230V / 50hz
MV-16	510 x 560 x 480 mm	410 x 450 x 220 mm	400 mm x 5mm	48 kg	25 M3/h	230V / 50hz
MV-21	610 x 630 x 500 mm	520 x 520 x 200 mm	500 mm x 5 mm	60 kg	25 M3/h	230V / 50hz

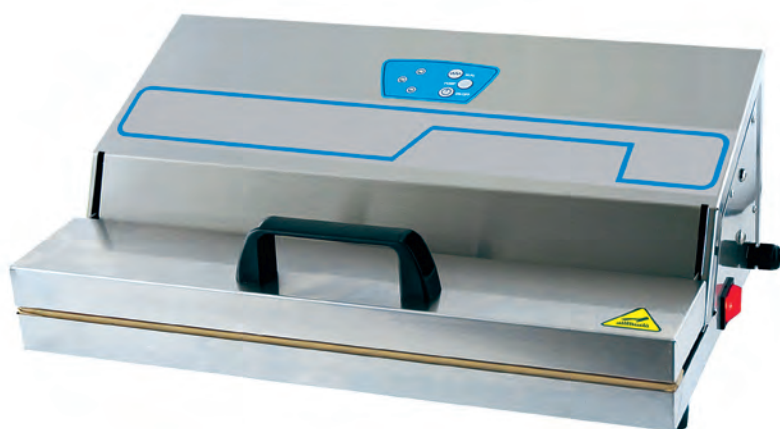

**Máquina envasadora al vacío sin cámara
Estructura acero-inox. Bolsa gofrada.**

Vacuum packaging machine without chamber
Stainless steel body. Embossed bag.

*Machine d'emballage sous vide sans chambre
Structure en acier inox. Sac gaufré.*

Ref.	Medidas Size Dimensions	Barra soldadura Seal bar Barre soudure	Bomba vacío Vacuum pump Pompe à vide	Peso Weight Poids	Voltaje (V) Voltage (V) Voltage (V)
MVS-430	490 x 295 x 180 mm	430 mm x 4 mm	28 L/min.	10 kg	220V / 50hz 95W



Máquina envasadora al vacío sin cámara
Estructura de ABS. Bolsa gofrada.

Vacuum packaging machine without chamber
ABS body. Embossed bag.

Machine d'emballage sous vide sans chambre
Structure en ABS. Sac gaufré.

Ref.	Medidas Size Dimensions	Barra soldadura Seal bar Barre soudure	Bomba vacío Vacuum pump Pompe à vide	Voltaje (V) Voltage (V) Voltage (V)
MVS-330	38 x 18 x 11 cm	330 mm	16 Lt/min.	220V



Máquina envasadora al vacío
Estructura de ABS y PVC

Vacuum packaging machine
ABS and PVC structure

Machine d'emballage sous vide
Structure en ABS et PVC

Ref.	Medidas Size Dimensions	Barra soldadura Seal bar Barre soudure	Bomba vacío Vacuum pump Pompe à vide	Peso Weight Poids	Voltaje (V) Voltage (V) Voltage (V)
MVS-100	35,7 x 14,8 x 7,3 cm	300 mm	10 Lt/min.	1,5 kg	220V

PARRILLA ENVASADORA | PACKAGING GRILL | GRILL À EMBALLER

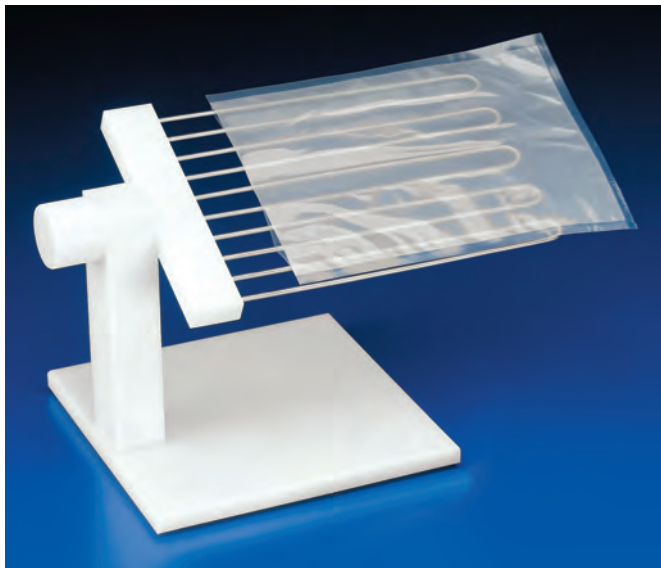

Parrilla envasadora para bolsa vacío
Base polietileno. Varillas acero inox. Pomo giratorio

Packing grill for vacuum bags
Polyethylene base. Stainless steel rods. Rotating knob

Grill à emballer pour sacs sous vide
Base polyéthylène. Tiges acier inox. Pommeau giratoire

Ref.	Medidas Size Dimensions
A-75	18,5 x 27 cm



Pala envasadora para bolsa vacío
Base polietileno.

Packing grill for vacuum bags
Polyethylene base.

Grill à emballer pour sacs sous vide
Base polyéthylène.

Ref.	Medidas Size Dimensions
A-76	38 x 18 cm
A-77	34 x 15 cm

BOLSAS VACIO | VACUUM BAGS | SACS SOUS VIDE



Bolsa vacío gofrada

Economic embossed vacuum bag

Sac sous vide gaufré économique

Ref.	Medidas Size Dimensions	Unidades Units Unités
BVX-1525	15 x 25 cm	100
BVX-1535	15 x 35 cm	100
BVX-1545	15 x 45 cm	100
BVX-2020	20 x 20 cm	100
BVX-2030	20 x 30 cm	100
BVX-2040	20 x 40 cm	100
BVX-2535	25 x 35 cm	100
BVX-3040	30 x 40 cm	100
BVX-3050	30 x 50 cm	100



Rollo gofrado 20 x 600

Embossed roller 20 x 600

Rouleau gaufré 20 x 600

Ref.	Medidas Size Dimensions	Unidades Units Unités
BVX-R20	20 x 600 cm	2

Bolsa vacío gofrada cocción

Embossed vacuum bag boiling

Sac sous vide gaufré cuisson

Ref.	Medidas Size Dimensions	Unidades Units Unités
BVXC-200300	20 x 30 cm	100



Bolsa vacío M8 COEX

M 8COEX vacuum bags

Sacs sous vide M8 COEX

Ref.	Medidas Size Dimensions	Unidades Units Unités
BV-140450	14 x 45 cm	1200
BV-150200	15 x 20 cm	1500
BV-150250	15 x 25 cm	1500
BV-175250	17,5 x 25 cm	1200
BV-180300	18 x 30 cm	1000
BV-200200	20 x 20 cm	1000
BV-200250	20 x 25 cm	1000
BV-200300	20 x 30 cm	1000
BV-200350	20 x 35 cm	1000
BV-200400	20 x 40 cm	1000
BV-250350	25 x 35 cm	1000
BV-300400	30 x 40 cm	1000
BV-350500	35 x 50 cm	500
BV-350600	35 x 60 cm	500
BV-400500	40 x 50 cm	500
BV-400600	40 x 60 cm	500



Bolsas vacío plata y oro "PRODUCTO DE CALIDAD"

Gold vacuum bags

Sacs sous vide d'or

Ref.	Medidas Size Dimensions	Tipo Type Type	Unidades Units Unités
BVPO-200300	20 x 30 cm	Oro	1200
BVPP-200300	20 x 30 cm	Plata	1200

Bolsa vacío M15 COEX

M15 COEX vacuum bags

Sacs sous vide M15 COEX

Ref.	Medidas Size Dimensions	Unidades Units Unités
BVE-200300	20 x 30 cm	500
BVE-250350	25 x 35 cm	500
BVE-300400	30 x 40 cm	500
BVE-350450	35 x 45 cm	300
BVE-350600	35 x 60 cm	300



Bolsas vacío plata-transparente

Transparent-silver vacuum bags

Sacs sous vide argent transparent

Ref.	Medidas Size Dimensions	Unidades Units Unités
BVP-175250	17,5 x 25 cm	1000
BVP-175300	17,5 x 30 cm	1000
BVP-200250	20 x 25 cm	1000
BVP-200300	20 x 30 cm	1000

Bolsa vacío cocción a 121° C

Vacuum bag boiled at 121° C

Sacs sous vide cuisson à 121° C

Ref.	Medidas Size Dimensions	Unidades Units Unités
BVC-150200	15 x 20 cm	1000
BVC-185250	18,5 x 25 cm	1000
BVC-200300	20 x 30 cm	500
BVC-250350	25 x 35 cm	500
BVC-300400	30 x 40 cm	500
BVC-350500	35 x 50 cm	500



**Bolsa asado con asa para microondas
Troquel zipper**

Roasted microwave bag with handle
Troquel zipper

Sac rôti avec poignée micro-ondes
Fermeture éclair découpée

Ref.	Medidas Size Dimensions	Unidades Units Unités
BVA-1	30,5 x 25 + 7,5 cm	500
BVA-2	35 x 29 + 7,5 cm	500
BVA-3	35 x 29 + 10 cm	500



**Bolsa de pescado con asa
Troquel zipper**

Fish bag with handle
Troquel zipper

Sac à poisson avec poignée
Fermeture éclair découpée

Ref.	Medidas Size Dimensions	Unidades Units Unités
BVA-4	30 x 25 + 5 cm	500

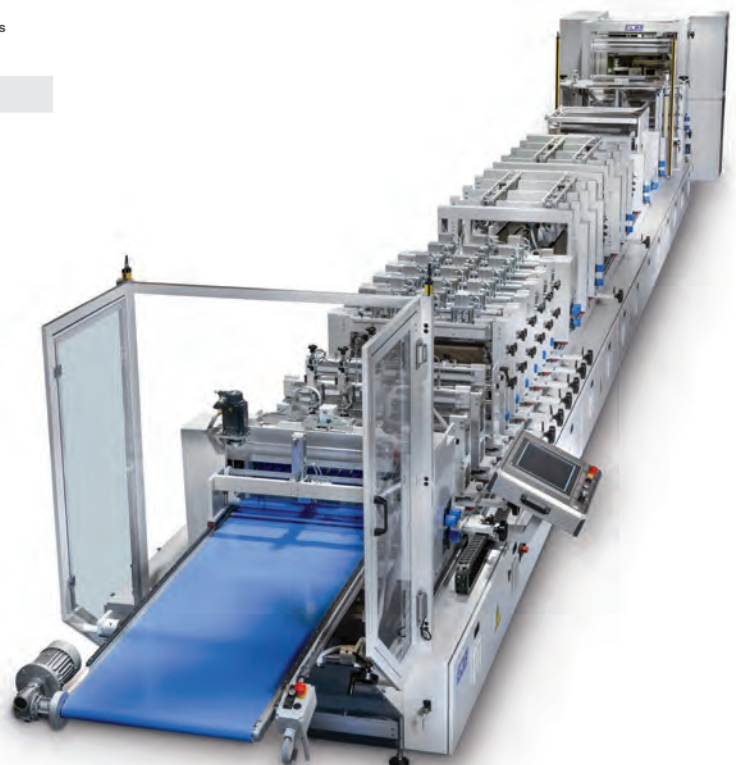

Nota: **Fabricamos bolsas a medida**



Termoselladora de barquetas 400 W
Incluye molde 95 x 135 y 135 x 195

Tray packaging thermo sealer 400 W
 Includes mold 95 x 135 and 135 x 195

Thermo machine à sceller de barquettes 400 W
Comprend moules 95 x 135 et 135 x 195

Ref.	Medidas Size Dimensions	Voltaje (V) Voltage (V) Voltage (V)
MT-152	18,7 x 40 cm	230



Termoselladora de barquetas 600 W 1/4 GASTRONORM

Tray packaging thermo sealer 600 W GASTRONORM

Thermo machine à sceller de barquettes 600 W GASTRONORM

Ref.	Medidas Size Dimensions	Voltaje (V) Voltage (V) Voltage (V)
MT-192	22,8 x 49 cm	230

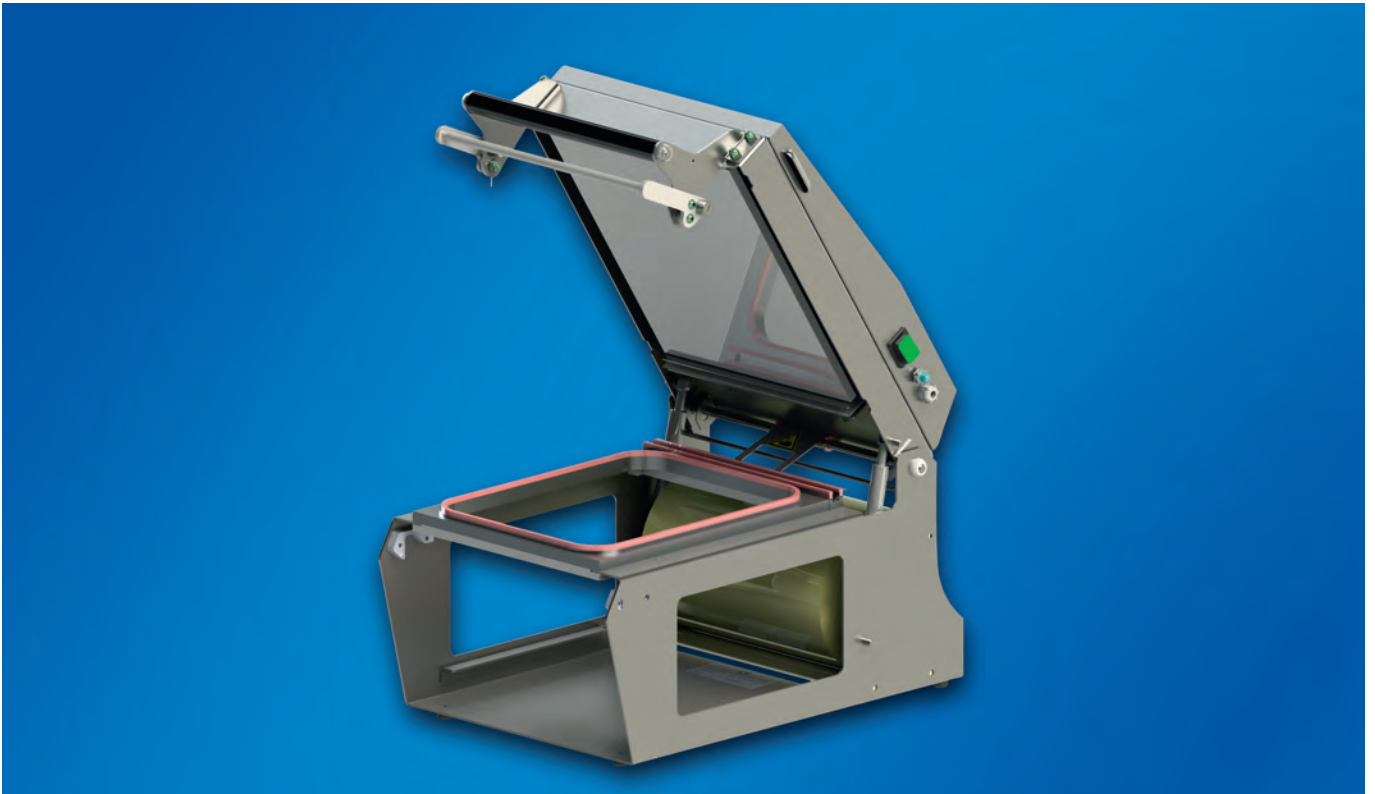

Termoselladora de barquetas 1200 W 1/2 GASTRONORM

Tray packaging thermo sealer 1200 W GASTRONORM

Thermo machine à sceller de barquettes 1200 W GASTRONORM

Ref.	Medidas Size Dimensions	Voltaje (V) Voltage (V) Voltage (V)
MT-270	34,5 x 53,5 mm	230



**Molde medidas
GN-1/4 barquetas para MT-192**

Mold sizes
GN-1/4 tray for MT-192

Moule mesures
GN-1/4 Barquettes for MT-192

Ref.	Medidas Size Dimensions
MTM-1/4	26,4 x 16,2 cm

**Molde medidas
GN-1/2 barquetas para MT-270**

Mold sizes
GN-1/2 tray for MT-270

Moule mesures
GN-1/2 Barquettes for MT-270

Ref.	Medidas Size Dimensions
MTM-1/2	32,5 x 26,5 cm

Bobina film termosellar

Termo packaging film roll

Boines film termo-sceller

Ref.	Medidas Size Dimensions
MTB-15	15 x 300 cm
MTB-20	20 x 300 cm
MTB-27	27 x 300 cm



0

5

Secamanos, Dispensadores papel celulosa, Papel celulosa, Dosificadores jabón, Grifos - caño electrónico, Grifos ducha, Lavamanos, Portacuchillos - Papeleras, Esterilizadores de cuchillos, Contenedores plástico, Contenedores papeleras acero-inoxidable, Cañon de ozono.

Hand dryer, Cellulose paper dispenser, Cellulose paper, Soap dispensers, Tap with electronic spout, Shower tap, Washbin, Knife holder - Waste baskets, Knives sterilizer, Plastic container, Stainless steel containers-bins, Ozone cannon.

Sèche-mains, Dispensateur papier cellulose, Papier cellulose, Doseurs de savon, Robinet électronique, Robinet douche, Lave - mains, Porte couteaux - Poubelles, stérilisateur de couteaux, Conteneurs plastique, Conteneur-poubelle acier inox, Canon à ozone.

101 - 120



Secamanos alta velocidad
Carcasa ABS blanco. Potencia 2050W. Velocidad 95 m/sg

High speed hand dryer
 White ABS frame. Power 2050W. Speed 95 m/sg.

Sèche-mains à grande vitesse
 Carcasse ABS blanc. Puissance 2050W. Vitesse 95 m/sg.

Ref.	Medidas Size Dimensions
SM-700	30 x 22 x 68,5 cm

SECAMANOS | HAND DRYER | SÈCHE MAINS



Secamanos
Control: célula de infrarrojos por proximidad. Caudal Aire : 225 m3/h. Interruptor aire: frío-caliente. Potencia 1650W

Hand dryer
 Control: Infra-red cell proximity control. Air-flow: 225 m3/h. Switch: cold or hot air. Power 1650W

Sèche-mains
 Control: cellule infrarouges par proximité. Débit air: 225 m3/h.
 Interrupteur: air froid ou chaud. Puissance 1650W



Secamanos
Control: célula de infrarrojos por proximidad. Caudal aire: 270 m3/h. Carcasa: acero satinado. Potencia 2500W

Hand dryer
 Infra-red cell proximity control. Air-flow: 270 m3/h. Frame: Satin finish steel. Power 2500W

Sèche mains
 Contrôle: cellule infrarouges par proximité. Débit air: 270m3/h.
 Carcasse: acier satiné. Puissance 2500W

Ref.	Medidas Size Dimensions	Voltaje (V) Voltage (V) Voltage (V)	Peso Weight Poids
SM-5	14 x 27 x 22 cm	220	2,4 kg

Ref.	Medidas Size Dimensions	Voltaje (V) Voltage (V) Voltage (V)	Peso Weight Poids
SM-6	20 x 26 x 21 cm	220	6,26 kg



Portabobinas plegable suelo acero-inox
Tipo de papel celulosa ref. PB-10

Stainless steel foldable standing paper reel holder
 Paper type : cellulose ref. PB-10

Porte bobines pliant sol acier inox
Type papier: cellulose réf. PB-10

Ref. Medidas
 Size
 Dimensions

PB-1 40 x 45 x 83 cm



Portabobinas mural y sobremesa acero-inox
Tipo de papel : celulosa ref. PB-10

Stainless steel foldable standing paper reel holder
 Paper type: cellulose ref. PB-10

Porte bobines mural/dessus de table acier inox
Type papier: cellulose réf. PB-10

Ref.

PB-1-M



Portarrollos higiénico inox

Cellulose paper dispenser
 Stainless steel hygienic paper roll holder

Porte rouleaux hygiénique inox

Ref. Diámetro
 Diamètre Largo
 Long Longueur

PB-2 Ø 25 cm 11,5 cm



Portarrollos higiénico epoxi blanco
Eje 4,5. Tipo de papel : celulosa ref. PB-30

White epoxy hygienic paper roll holder
 Axis 4,5 cm. Paper type : cellulose ref. PB-30

Porte rouleaux hygiénique époxy blanc
Axe 4,5 cm. Type papier : cellulose réf. PB-30

Ref. Diámetro
 Diamètre Largo
 Long Longueur

PB-3 Ø 25 cm 11,5 cm



Portarrollos higiénico WC
Con visor.

Hygienic paper roll holder
 With visier.

Porte rouleaux hygiénique
Avec visieur.

Ref. Medidasz
 Size
 Dimensions Color
 Couleur

PB-21 32,5 x 30,5 x 13 cm ○

PB-21N 32,5 x 30,5 x 13 cm ●



Dispensador de papel tipo mecha
Tipo de papel : celulosa ref. PB-50

Mecha paper dispenser
Paper type : cellulose ref. PB-50

Distributeur de papier de type mèche
Type papier : cellulose réf. PB-50

Ref.	Medidas Size Dimensions
PB-9	26,5 x 35 cm



Dispensador papel tipo mecha
Con visor.

Mini mecha paper dispenser
With viewer.

Dispensateur de papier de type mèche
Avec viseur

Ref.	Medidas Size Dimensions	Color Colour Couleur
PB-24	32 x 21 x 22 cm	○
PB-24N	32 x 21 x 22 cm	●



Dispensador papel tipo mecha
Tipo papel: ref. PB-50

Mecha paper dispenser

Distributeur de papier de type mèche
Type papier : cellulose ref. PB-50

Ref.	Diámetro Diameter Diamètre	Altura Height Hauteur
PB-12	Ø 32 cm	25 cm



Dispensador toallitas Z/Z acero inox
Tipo de papel : ref. PB-70

Z/Z folded towel dispenser
Paper type : ref. PB-70

Distributeur lingettes Z/Z
Type papier: ref. PB-70

Ref.	Medidas Size Dimensions
PB-8	33 x 26,5 x 12 cm



Dispensador toallitas Z/Z epoxi blanco
Tipo de papel : ref. PB-70

Z/Z folded towel dispenser
Paper type : ref. PB-70

Distributeur lingettes Z/Z
Type papier : ref. PB-70

Ref.	Medidas Size Dimensions
PB-7	31 x 26,5 x 12 cm



Dispensador toallitas Z/Z ABS
Con visor.

Z/Z towels dispenser ABS
With viewer.

Dispensateur lingettes ZZ ABS
Avec viseur.

Ref.	Medidas Size Dimensions	Color Colour Couleur
PB-22	37 x 27,5 x 13,5 cm	○
PB-22N	37 x 27,5 x 13,5 cm	●



Dispensador de papel tipo mecha mini
Con visor

Mini mecha paper dispenser
With viewer

Dispensateur de papier de type mèche mini
Avec viseur

Ref.	Medidas Size Dimensions	Color Colour Couleur
PB-23	14 x 16 x 29 cm	○
PB-23N	14 x 16 x 29 cm	●



Dispensador de papel tipo mecha mini
Tipo de papel : celulosa ref. PB-40

Mini mecha paper dispenser
 Paper type : cellulose ref. PB-40

Distributeur de papier de type mèche
Type papier : cellulose réf. PB-40

Ref.	Medidas Size Dimensions
PB-11	15 x 27 cm

PAPEL CELULOSA | CELLULOSE PAPER | PAPIER CELLULOSE



Bobina mecha 2 capas

Roll of 2-layer cellulose paper

Bobine cellulose 2 épaisseurs

Ref.	Largo Long Longueur	Unidades Units Unités
PB-40	65 m	12
PB-50	180 m	6

Bobina celulosa industrial 2 capas

Roll of 2-layer industrial paper

Rouleau cellulose industrielle 2 épaisseurs

Ref.	Largo Long Longueur	Unidades Units Unités
PB-10	500 m	2

Rollo papel higiénico dos capas

Reel of 2-layer hygienic paper

Bobine cellulose hygiénique 2 épaisseursZ

Ref.	Largo Long Longueur	Unidades Units Unités
PB-30	150 m	18

Totallitas Z/Z
200 uds x 20 paquetes

Z/Z folded towel
 200 units x 20 packs

Lingettes Z/Z
200 units x 20 paquet

Ref.
PB-70



Dosificador de jabón luxe

Deluxe soap dispensers

Doseur de savon luxe

Ref.	Medidas Size Dimensions	Capacidad Capacity Capacité
D-1	12 x 11 cm	1 l



Dosificador de jabón

Soap dispenser

Doseur de savon

Ref.	Diámetro Diameter Diamètre	Altura Height Hauteur	Capacidad Capacity Capacité
D-2	Ø 13 cm	24 cm	2 l



**Dosificador de jabón
Color blanco**

Soap dispenser
White colour

*Doseur de savon
Couleur blanc*

Ref.	Medidas Size Dimensions	Capacidad Capacity Capacité
D-4-B	9 x 10 x 22,5 cm	1 l



Dosificador jabón cromado

Soap dispenser chrome

Doseur de savon chromé

Ref.	Medidas Size Dimensions	Capacidad Capacity Capacité
D-4-C	9 x 10 x 22,5 cm	1 l



**Dosificador jabón
Color blanco o negro. Con visor**

Soap dispenser
White or black colour. With viewer

*Doseur de savon
Couleur blanc ou noir. Avec viseur*

Ref.	Medidas Size Dimensions	Capacidad Capacity Capacité
D-7	13 x 9,5 x 21,5 cm	0,8 l
D-7-N	13 x 9,5 x 21,5 cm	0,8 l



Dosificador jabón

Soap dispenser

Doseur de savon

Ref.	Medidas Size Dimensions	Capacidad Capacity Capacité
D-8	11,6 x 5,8 x 17,5 cm	0,8 l



**Dosificador de jabón electrónico
Color blanco**

Electronic soap dispenser
White colour

*Doseur de savon
Couleur blanc*

Ref.	Medidas Size Dimensions	Capacidad Capacity Capacité
D-11	14 x 11,8 x 23,4 cm	1 l



**Dosificador de gel electrónico
Color blanco**

Electronic gel dispenser
White colour

*Doseur de gel
Couleur blanc*

Ref.	Medidas Size Dimensions	Capacidad Capacity Capacité
D-12	13 x 12 x 27 cm	0,9 l

GRIFO-CAÑO ELECTRÓNICO | TAP WITH ELECTRONIC SPOUT | ROBINET ÉLECTRONIQUE



Soporte metálico negro con dosificador electrónico de gel y papelera de plástico con pedal negro.

Black metal support with electronic dispenser gel and plastic bin with black pedal.

Support en métal noir avec distributeur électronique bac à gel et plastique à pédale noire.

Ref.	Medidas Size Dimensions
D-50	30 x 30 x 130 cm



**Grifo con kit electrónico
Sensor infrarrojo.**

Tap with electronic kit
Infrared sensor.

*Robinet avec kit électronique
Senseur infrarouge.*

Ref.	Voltaje (V) Voltage (V) Voltage (V)	Tensión de trabajo (V) Working voltage (V) Tension de travail (V)
LM-10	220	12

**Grifo con kit electrónico pilas
Grifo un agua. Sensor infrarrojo. 4 pilas AA de 1,5V**

Tap with battery powered electronic kit
Single water tap. Infrared sensor. Four 1,5V AA batteries.

*Robinet avec kit électronique à piles
Robinet 1 eau. Senseur infrarouge. 4 piles AA de 1,5V*

Ref.	Tensión de trabajo (V) Working voltage (V) Tension de travail (V)
LM-10-P	6





Caño giratorio eco

Eco swivel spout

Bec giratoire éco

Ref.

LM-1-2

Válvula mezcladora 2 aguas

Double water mixer valve

Valve mélangeuse 2 eaux

Ref.

LM-11

Caño giratorio

Swivel spout

Bec giratoire

Ref.

LM-1-3

Pedal 1 agua

Single water pedal

Pédale 1 eau

Ref.

LM-2-1

Pedal 2 aguas

Double water pedal

Pédale 2 eaux

Ref.

LM-2-2

Pulsador temporizador

Press button timer

Bouton poussoir minuterie

Ref.

LM-1-1



**Grifo ducha extensible de un agua.
Piña blanca.**

Single extendable shower tap.
White shower head

*Robinet dluche extensible une eau.
Pomme blanche.*

Ref.

LM-21



**Grifo ducha extensible de dos aguas.
Piña blanca.**

Double extendable shower tap.
White shower head

*Robinet douche extensible deux eaux.
Pomme blanche.*

Ref.

LM-22



**Grifo ducha extensible de un agua
Piña negra**

Single extendable shower tap
White shower head

*Robinet douche extensible une eau
Pomme noire.*

Ref.

LM-23



Mural dos aguas

Double water wall tap

Robinet mural deux eaux

Ref.

LM-26

**Grifo ducha extensible de dos aguas
Piña negra**

Double extendable shower tap
White shower head

*Robinet douche extensible deux eaux.
Pomme noire*

Ref.

LM-24



**Caño giratorio con monomando codo
Acoplable para grifos ducheta**

Single lever mixer wall tap with swivel spout

Robinet mural à bec giratoire mitigeur

Ref.

LM-27

Flexo ducheta, 120 cm

Hose, 120 cm

Tuyau, 120 cm

Ref.

Para
For
Pour

LM-21-2

LM-21, LM-22

Flexo ducheta, 120 cm, transparente

Hose, 120 cm, transparent

Tuyau, 120 cm, transparent

Ref.

Para
For
Pour

LM-23-2

LM-23, LM-24

Soporte pared y piña

Wall holder and head shower

Support de mur et robinet de douche

Ref.

Para
For
Pour

LM-21-3

LM-21, LM-22, LM-23, LM-24

Muelle para flexo ducha

Spring for hose

Ressort pour tuyau

Ref.

Para
For
Pour

LM-21-4

LM-21, LM-22, LM-23, LM-24





Piña ducheta para ref. LM-21 y LM-22

Shower head adaptable to ref. LM-21 and LM-22

Pomme de douche pour ref. LM-21 et LM-22

Ref.

LM-21-1

Piña ducheta para ref. L-23 y LM-24

Shower head for ref. LM-23 and LM-24

Pomme de douche pour réf. LM-23 et LM-24

Ref.

LM-23-1

Caño giratorio acoplable para grifos ducha.

Revolving spout can be fitted to shower taps

Bec giratoire adaptable pour robinets douche

Ref.

LM-25

LAVAMANOS | WASHBASIN | LAVE-MAINS



Lavamanos inox con pulsador de pie Mezclador agua fría y caliente. Caño giratorio. Alto mas 30 cm de PETO

Stainless steel washbasin with foot operated push button
Cold and hot warer mixer. Swivel spout.

*Lave-mains inox avec bouton-poussoir actionné par le pied
Mélangeur eau froide et chaude. Bec giratoire.*

Ref.

LM-1

Medidas
Size
Dimensions

45 x 45 x 86 cm



**Lavamanos inox con pedal
Mezclador agua fría y caliente. Caño fijo.**

Stainless steel washbasin with pedal
Cold and hot water mixer. Fixed spout.

*Lave-mains inox avec pédale
Mélangeur eau froide et chaude. Bec fixe.*

Ref.	Medidas Size Dimensions
LM-2	45 x 45 x 85 cm

**Lavamanos inox con 2 pedales
Mezclador agua fría y caliente.**

Stainless steel washbasin with 2 pedals
Cold and hot water mixer.

*Lave-mains inox. avec 2 pédale
Mélangeur eau froide et chaude*

Ref.	Medidas Size Dimensions
LM-2-P	45 x 45 x 85 cm



**Lavamanos inox mural
Con mezclador. Pulsador de rodilla. Caño giratorio**

Wall stainless steel washbasin
With mixer. Knee push button. Swivel spout.

*Lave-mains inox mural
Avec mixeur. Bouton poussoir genou. Bec
giratoire.*

Ref.	Medidas Size Dimensions
LM-4	35 x 30 x 21,5 cm

Peto para ref. LM-4

Guard for ref. LM-4

Plastron pour réf. LM-4

Ref.
LMP-4



**Lavamanos inox mural
Pulsador de rodilla. Mezclador agua fría y
caliente. Caño fijo.**

Wall stainless steel washbasin
Knee push button. Cold and hot water
mixer. Fixed spout.

*Lave-mains inox mural avec mélangeur
Bouton poussoir genou. Mélangeur eau
froide et chaude. Bec fixe.*

Ref.	Medidas Size Dimensions
LM-5	45 x 45 x 21,5 cm

Peto para ref. LM-2, LM-5

Guard for ref. LM-2, LM-5

Plastron pour réf. LM-2, LM-5

Ref.
LMP-5



Papelera rejilla, acero-inox

Grille waste paper basket, stainless steel

Poubelle rejilla, acier-inox

Ref.	Medidas Size Dimensions
A-95	60 x 7,5 x 22 cm



**Portacuchillos protegido, acero-inox
Con tres ranuras para cuchillos y chaira
ovalada-redonda**

Encased knife holder, stainless steel
Three grooves for knives and oval
professional sharpener

Porte couteaux et fusil ovale rond, acier inox
Avec trois rainures pour couteaux et fusil
ovale rond

Papelera, acero inox

Waste paper bin, stainless steel

Poubelle, acier inox

Ref.	Medidas Size Dimensions
EC-10	38 x 9 x 38 cm

Ref.	Medidas Size Dimensions
A-90	33 x 13 x 27,5 cm



**Esterilizador de cuchillos por ozono
Acero-inox, Duración aconsejable 15 minutos**

Ozone Knife steriliser
Stainless steel, Recommended time 15 minutes

Stérilisateur de couteaux par ozone
Acier inox, recommandé 15 minutes

Ref.	Medidas Size Dimensions	Voltaje (V) Voltage (V) Voltage (V)
EC-1	60 x 10 x 35 cm	220 V



**Cañon de ozono 10 G/H con temporizador.
Producción 10 gramos hora.**

Ozone cannon 10 G/H with timer.
Production 10 grams per hour.

Canon à ozone 10 G/H avec minuterie.
Production 10 grammes par heure.

Ref.	Medidas Size Dimensions	Voltaje (V) Voltage (V) Voltage (V)
OZ-10G	23 x 18 x 17 cm	220 V



Esterilizador de cuchillos por agua caliente
De acero-inox, resistencia de 750 W estanco y una temperatura aconsejable de 82°.

Hot water knife steriliser
Stainless steel, resistance a 750 W watertight and a recommended temperature of 82°.

Stérilisateur de couteaux par eau chaude
Acier inox, résistance 750 W étanche, température recommandée 82°.

Ref.	Medidas Size Dimensions	Voltaje (V) Voltage (V) Voltage (V)
EC-5-45	35 x 10 x 45 cm	220





**Armario esterilizador por lámpara de ozono
2 barras de imán. Puerta de metacrilato transparente para poder acceder totalmente a su interior, acero inox**

Ozone lamp steriliser cabinet
Two-bar magnet. Transparent methacrylate door for easy access, stainless steel.

*Armoire stérilisation par lampe d'ozone
2 barre aimant. Porte en méthacrylate transparent pour pouvoir accéder complètement à l'intérieur, acier inox.*

Ref.	Medidas Size Dimensions	Voltaje (V) Voltage (V) Voltage (V)
EC-35	35 x 58 x 12 cm	220

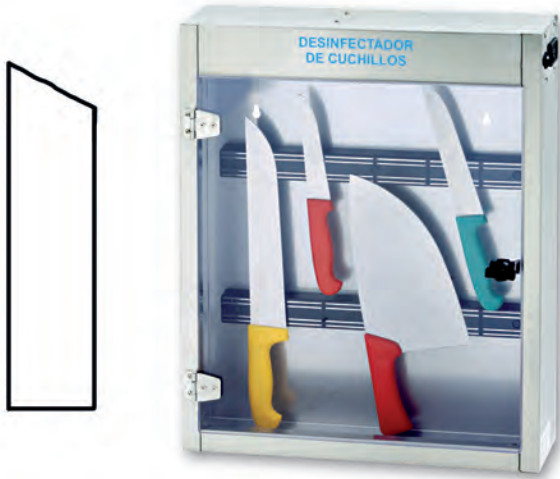

**Armario esterilizador por lámpara de ozono
2 barras de imán. Puerta de metacrilato para poder acceder totalmente a su interior, acero-inox.**

Techo inclinado

Ozone lamp steriliser cabinet
Two-bar magnet. Transparent methacrylate door for easy access, stainless steel.

Sloping top

*Armoire stérilisation par lampe d'ozone
2 barre aimant. Porte en méthacrylate transparent pour pouvoir accéder complètement à l'intérieur, acier-inox.*

Toit incliné

Ref.	Medidas Size Dimensions	Voltaje (V) Voltage (V) Voltage (V)
EC-55	47 x 58 x 12 cm	220



**Armario esterilizador por lámpara de ozono
4 barras de imán. Puerta de metacrilato transparente para poder acceder totalmente a su interior, acero inox.**

Techo inclinado

Ozone lamp steriliser cabinet
4-bar magnet. 2 transparent methacrylate door for easy access, stainless steel.

Sloping top

*Armoire stérilisation par lampe d'ozone
4 barre aimant. 2 porte en méthacrylate transparent pou pouvoir accéder complètement à l'intérieur, acier-inox*

Toit incliné

Ref.	Medidas Size Dimensions	Voltaje (V) Voltage (V) Voltage (V)
EC-105	100 x 59 x 12 cm	220



Armario esterilizador ultravioleta
Soporte inox 10 cuchillos. Puerta plexiglas transparente ahumado. Lámpara: UVC 15W. Temporizador: reloj 0 a 2 horas. Duración aconsejada 1h 30. Acero-inox.

UV steriliser cabinet
 Stand: stainless steel 10 knives. Door: transparent smoked Plexiglas.
 Lamp: UVC 15W. Timer: 0 to 2 hrs clock. Recommended duration: 1h 30. Stainless steel.

Armoire stérilisatrice ultraviolette
Support: inox 10 couteaux. Porte: plexiglas transparent teinté.
Lampe: UVC 15W. Minuterie: horloge 0 à 2h. Durée recommandée: 1h 30. Acier-inox

Ref.	Medidas Size Dimensions	Voltaje (V) Voltage (V) Voltage (V)
ECU-25	35 x 12,5 x 57,5 cm	220



Armario esterilizador ultravioleta
Soporte: inox 20 cuchillos. Puerta: plexiglas transparente ahumado. Lámpara: UVC 15W. Temporizador: reloj 0 a 2h. Duración aconsejada: 1h 30. Acero-inox.

UV steriliser cabinet
 Stand: stainless steel 20 knives. Door: transparent smoked plexiglas.
 Lamp: UVC 15W. Timer: 0 to 2 h clock. Recommended duration: 1h 30. Stainless steel.

Armoire stérilisatrice ultraviolette
Support: inox 20 couteaux. Porte: plexiglas transparent teinté.
Lampe: UVC 15W. Minuterie : horloge 0 à 2h. Durée recommandée 1h 30. Acier Inox.

Ref.	Medidas Size Dimensions	Voltaje (V) Voltage (V) Voltage (V)
ECU-50	44 x 12,5 x 57,5 cm	220



Armario esterilizador ultravioleta
Soporte: inox 30 cuchillos. Puerta: plexiglas transparente ahumado. Lámpara 2x15W. Temporizador: reloj 0 a 2 horas. Duración aconsejada: 1h 30. Acero-inox.

UV steriliser cabinet
 Stand: stainless steel 30 knives. Door: transparent smoked plexiglas.
 Lamp: 2x15W. Timer: 0 to 2 h clock. Recommended duration: 1h 30. Stainless steel.

Armoire stérilisatrice ultraviolette
Support: inox 30 couteaux. Porte: plexiglas transparent teinté.
Lampe: 2x15W. Minuterie: horloge 0 à 2h. Durée recommandée: 1h 30. Acier inox.

Ref.	Medidas Size Dimensions	Voltaje (V) Voltage (V) Voltage (V)
ECU-100	75 x 12,5 x 57,5 cm	220



Carro contenedor de basura
Tapa abatible con pedal.

Two-wheel mobile garbage bin
Pedal lift-top

Chariot conteneur de déchets
Couvercle rabattable avec pédale.

Ref.	Medidas Size Dimensions	Capacidad Capacity Capacité	Color Colour Couleur
W-60	50,5 x 44,5 x 70 cm	60 l	○ ● ●



Carro contenedor de basura
Tapa abatible con pedal.

Two-wheel mobile garbage bin
Pedal lift top.

Chariot conteneur de déchets
Couvercle rabattable avec pédale.

Ref.	Medidas Size Dimensions	Capacidad Capacity Capacité	Color Colour Couleur
W-80	50,5 x 44,5 x 84,5 cm	80 l	● ●



Carro contenedor de basura
Tapa abatible con pedal.

Two-wheel mobile garbage bin
Pedal-lift top.

Chariot conteneur de déchets
Couvercle rabattable avec pédale.



Ref.	Medidas Size Dimensions	Capacidad Capacity Capacité	Color Colour Couleur
W-120	55 x 58 x 93 cm	120	○ ● ● ● ● ● ● ●



Carro contenedor de basura
Tapa abatible con pedal.

Two-wheel mobile garbage bin
Pedal-lift top.

Chariot conteneur de déchets
Couvercle rabattable avec pédale.

Ref.	Medidas Size Dimensions	Capacidad Capacity Capacité	Color Colour Couleur
W-240	74 x 58 x 107 cm	240 l	● ●



**Cubo de basura con pedal
Con aro sujeta bolsas. 28 l**

Pedal bin
With hoop holds bags. 28 l

*Poubelle à pédale
Avec cerceau détient des sacs. 28 l*

Ref.	Medidas Size Dimensions	Color Colour Couleur
W-28	33 x 35 x 49,5 cm	○



**Carro contenedor de basura
Tapa abatible con pedal.**

Two-wheel mobile garbage bin
Pedal lift top.

*Chariot conteneur de déchets
Couvercle rabattable avec pédale.*

Ref.	Medidas Size Dimensions	Capacidad Capacity Capacité	Color Colour Couleur
W-81	55 x 58 x 93 cm	80 l	○

CONTENEDORES - PAPELERAS ACERO-INOXIDABLE | BINS - STAINLESS STEEL CONTAINERS-BINS | CONTENEUR-POUBELLE ACIER INOX



**Papelera basculante acero-inox
Tapa basculante. Parte superior extraíble**

Stainless steel container
Lift-top. Removable upper part

*Conteneur acier inox
Couvercle basculant. Partie supérieure amovible*

Ref.	Medidas Size Dimensions	Capacidad Capacity Capacité
WI-35	30 x 20 x 70 cm	35 l



Papelera basculante acero-inox
Tapa basculante. Parte superior extraible

Stainless steel container
 Lift-top. Removable upper part

Conteneur acier inox
Couvercle basculant. Partie supérieure amovible

Ref.	Medidas Size Dimensions	Capacidad Capacity Capacité
WI-75	40 x 30 x 90 cm	75 l



Contenedor acero-inox
Tapa con pedal. Puerta frontal para extraer bolsa. Asa H72

Stainless steel container
 Pedal-lift top. Frontal door for bag removal. Handle H 72

Conteneur acier inox
Couvercle avec pédale. Porte avant pour extraire le sac. Asa H 72

Ref.	Medidas Size Dimensions	Capacidad Capacity Capacité
WI-70	46 x 36 x 72 cm	70 l



Contenedor acero-inox
Tapa con pedal. Puerta frontal para extraer bolsa. Asa H92

Stainless steel container
 Pedal-lift top. Frontal door for bag removal. Handle H 92

Conteneur acier inox
Couvercle avec pédale. Porte avant pour extraire le sac. Asa H 92

Ref.	Medidas Size Dimensions	Capacidad Capacity Capacité
WI-90	46 x 36 x 92 cm	90 l



Contenedor acero-inox
Tapa con pedal

Stainless steel container
 Pedal-lift top

Conteneur acier inox
Couvercle avec pedale

Ref.	Diámetro Diameter Diamètre	Altura Height Hauteur	Capacidad Capacity Capacité
WI-110	Ø 40 cm	86 cm	110 l



Contenedor acero-inox
Tapa con pedal. Tapa extraíble

Stainless steel container
 Pedal-lift top. Removable top

Conteneur acier inox
Couvercle avec pédale. Couvercle amovible

Ref.	Diámetro Diameter Diamètre	Altura Height Hauteur	Capacidad Capacity Capacité
WI-60	Ø 40 cm	60 cm	60 l



Indicadores de turno, Expendedores de tickets, Impresora de tickets, Rollo tickets, Organizador de filas, Exterminadores de insectos, Detector contador billetes - monedas, Reloj-temperatura.

Queue indicators, Ticket dispenser, Tickets printer, Ticket roll, Row organizer, Insect exterminator, Counter detector bill - coin, Clock - temperature.

Indicateur de numero, Dispensateu tickets, Imprimante tickets, Rouleaux de tickets, Organisateur de rangée, Exterminateur d'insectes, Compteur détecteur billets - monnaie, Horloge - température.

121 - 134



Indicador de turno
Visor de dos dígitos con mando a distancia.

Queue indicator
Two-digit screen with remote control.

Indicateur de numéro
Visseur à deux chiffres avec commande à distance

Ref.	Medidas Size Dimensions	Altura dígitos (cm) Digits height (cm) Hauteur chiffres (cm)	Voltaje (V) Voltage (V) Voltage (V)
IT-5-MD	30 x 26 cm	13	220



Indicador de turno
Visor de dos dígitos y mando a distancia con visor.

Queue indicator
Two-digit screen with remote control with screen.

Indicateur de numéro
Visseur à deux chiffres et commande à distance avec viseur

Ref.	Medidas Size Dimensions	Altura dígitos (cm) Digits height (cm) Hauteur chiffres (cm)	Voltaje (V) Voltage (V) Voltage (V)
IT-5-MDV	30 x 32 cm	13	220



Indicador de turno
Visor de dos dígitos con mando con cable de 1 función.

Queue indicator
Two-digit screen with control pad with cable 1 function.

Indicateur de numéro
Visseur à deux chiffres et commande avec fil 1 fonction.

Ref.	Medidas Size Dimensions	Altura dígitos (cm) Digits height (cm) Hauteur chiffres (cm)	Voltaje (V) Voltage (V) Voltage (V)
IT-6-ECO	34,5 x 24 cm	12,5	220V



Indicador de turno
Visor de dos dígitos con mando con cable de 3 funciones.

Queue indicator
Two-digit screen with control pad with cable 3 function.

Indicateur de numéro
Visseur à deux chiffres et commande avec fil 3 fonctions.

Ref.	Medidas Size Dimensions	Altura dígitos (cm) Digits height (cm) Hauteur chiffres (cm)	Voltaje (V) Voltage (V) Voltage (V)
IT-6	34,5 x 24 cm	12,5	220V

Indicador de turno. Visor de dos dígitos con mando con cable estanco de 1 función.

Queue indicator. Two-digit viewfinder with remote control with waterproof cable 1 function.

Indicateur de numéro. Viseur à deux chiffres avec télécommande avec câble étanche 1 fonction.

Ref.	Medidas Size Dimensions	Altura dígitos (cm) Digits height (cm) Hauteur chiffres (cm)	Voltaje (V) Voltage (V) Voltage (V)
IT-6-E	34,5 x 24 cm	12,5	220V

Indicador de turno. Visor de dos dígitos con mando con cable. Conexión balanzas Dibal de 1 función.

Queue indicator. Two-digit screen with control pad with cable. Dibal balance connection 1 function.

Indicateur de numéro. Viseur à deux chiffres et commande avec fil. Connexion balance Dibal 1 fonction.

Ref.	Medidas Size Dimensions	Altura dígitos (cm) Digits height (cm) Hauteur chiffres (cm)	Voltaje (V) Voltage (V) Voltage (V)
IT-6-B	34,5 x 24 cm	12,5	220V



Indicador de turno
Visor dos dígitos con mando a distancia de 1 función.

Queue indicator
 Two-digit screen with remote control 1 function.

Indicateur de numéro
Visueur à deux chiffres et commande à distance 1 fonction.

Ref.	Medidas Size Dimensions	Altura dígitos (cm) Digits height (cm) Hauteur chiffres (cm)	Voltaje (V) Voltage (V) Voltage (V)
IT-6-MD-ECO	34,5 x 24 cm	12.5	220



Indicador de turno. Visor dos dígitos con mando a distancia de 4 funciones. Con 9 colores de dígitos.

Queue indicator. Two-digit screen with remote control 4 functions.
 With 9 digit colors.

Indicateur de numéro. Visueur à deux chiffres et commande à distance 4 fonctions. Avec des couleurs à 9 chiffres.

Ref.	Medidas Size Dimensions	Altura dígitos (cm) Digits height (cm) Hauteur chiffres (cm)	Voltaje (V) Voltage (V) Voltage (V)
IT-6-MD	34,5 x 24 cm	12.5	220



Indicador de turno. Visor dos dígitos con cable y visor, adelanta, retrocede. Numérico

Queue indicator. Two-digit screen with remote control pad with cable and screen, goes forward and back and can select numbers. Numeric.

Indicateur de numéro
Visueur à deux chiffres et commande à distance avec fil et visueur, avance et recule et sélection numérique

Ref.	Medidas Size Dimensions	Altura dígitos (cm) Digits height (cm) Hauteur chiffres (cm)	Voltaje (V) Voltage (V) Voltage (V)
IT-6-X	34,5 x 24 cm	12.5	220



Indicador de turno
Batería 12v. Visor dos dígitos. Mando a distancia

Queue indicator
 Battery 12V. Two digit-screen. Remote control

Indicateur de numéro
Visueur à deux chiffres batterie 12 V télécommande.

Ref.	Medidas Size Dimensions	Voltaje (V) Voltage (V) Voltage (V)	Altura dígitos (cm) Digits height (cm) Hauteur chiffres (cm)
IT-7-MD	28 x 24,5 cm	220V/12V	15



Indicador de turno
Visor dos dígitos. Mando con cable de 2 funciones.

Queue indicator
 Two-digit screen with control pad with cable 2 functions.

Indicateur de numéro
Visueur à deux chiffres et commande avec fil 2 fonctions.

Ref.	Medidas Size Dimensions	Altura dígitos (cm) Digits height (cm) Hauteur chiffres (cm)	Voltaje (V) Voltage (V) Voltage (V)
IT-8	24,5 x 15 cm	9.5	110V - 220V



Indicador de turno
Visor dos dígitos. Mando a distancia de 2 funciones.

Queue indicators
2 digits screen remote control 2 functions.

Indicateur de numéro
Viseur à deux chiffres. Télécommande 2 fonctions.

Ref.	Medidas Size Dimensions	Altura dígitos (cm) Digits height (cm) Hauteur chiffres (cm)	Voltaje (V) Voltage (V) Voltage (V)
IT-8-MD	24,5 x 15 cm	9,50	110V - 220V

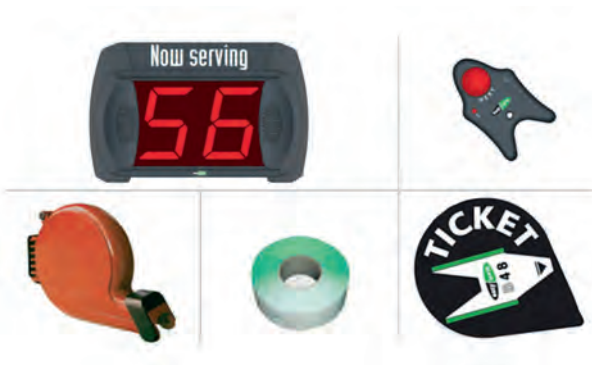

Indicador de turno. Visor 2 dígitos. Mando a distancia.
Kit: pantalla + mando + dispensador rojo + 1 rollo + cartel

Queue indicators. Two digit screen remote control.
Kit: screen + control + red dispenser + 1 roll + poster

Indicateur de numéro. Viseur à deux chiffres. Télécommande.
Kit: écran + contrôle + distributeur rouge + 1 rouleau + poster

Ref.	Medidas Size Dimensions	Altura dígitos (cm) Digits height (cm) Hauteur chiffres (cm)	Voltaje (V) Voltage (V) Voltage (V)
IT-9-MD	30 x 20 cm	10	220 V



Indicador de turno.
Visor 3 dígitos, mando con cable de 3 funciones.

Queue indicator
Three-digit screen, control pad with cable 3 functions.

Indicateur de numéro
Viseur 3 chiffres, commande avec fil 3 fonctions.

Ref.	Medidas Size Dimensions	Altura dígitos (cm) Digits height (cm) Hauteur chiffres (cm)	Voltaje (V) Voltage (V) Voltage (V)
IT-4	34,5 x 24 cm	12,5	220



Indicador de turno
Visor 3 dígitos con mando a distancia de 4 funciones.

Queue indicator
3 digits screen with remote control 4 functions.

Indicateur de numéro
Viseur 3 chiffres avec télécommande 4 fonctions.

Ref.	Medidas Size Dimensions	Altura dígitos (cm) Digits height (cm) Hauteur chiffres (cm)	Voltaje (V) Voltage (V) Voltage (V)
IT-4-MD	34,5 x 24 cm	12,5	220



Indicador de turno
Visor 3 dígitos, mando con cable y visor. Adelanta, retrocede y selección numérico

Queue indicator
 Three digits screen, control cable pad, goes back and forward.

Indicateur de numéro
Viseur 3 chiffres, commande avec fil, avance et recule

Ref.	Medidas Size Dimensions	Altura dígitos (cm) Digits height (cm) Hauteur chiffres (cm)	Voltaje (V) Voltage (V) Voltage (V)
IT-4-X	34,5 x 24 cm	12,5	220



Indicador de turno
Visor 2 dígitos + 1 dígito punto atención. Mando con visor.

Queue indicator
 2+1 digit screen. Control pad with screen.

Indicateur de numéro
Viseur 2 chiffres avec lieu d'attention

Ref.	Medidas Size Dimensions	Altura dígitos (cm) Digits height (cm) Hauteur chiffres (cm)	Voltaje (V) Voltage (V) Voltage (V)
IT-10	34,5 x 24 cm	12,95 / 9,5	220

Mando con visor para ref. IT-10

Control pad with screen for ref. IT-10

Commande avec viseur pour réf. IT-10

Ref.

IT-10-1



Indicador de turno con punto de atención
Visor 3+1 dígitos. Mando con visor. Base telefónica.

Queue indicator displaying free counter number
 3+1 digit screen. Control pad with screen.

Écran indicateur de numéro avec lieu d'attention
Viseur à 3+1 chiffres.

Ref.	Medidas Size Dimensions	Altura dígitos (cm) Digits height (cm) Hauteur chiffres (cm)	Voltaje (V) Voltage (V) Voltage (V)
IT-11	34,5 x 24 cm	12,5 x 9,5	220

Mando con visor para ref. IT-11

Control pad with screen for ref. IT-11

Commande avec viseur pour réf. IT-11

Ref.

IT-11-1



Indicador de turno
Panel 3 secciones. Visor 2+4 dígitos. Mando con cable.

Queue indicator
 3-section panel. 2+4 digits screen. Control pad with cable.

Indicateur de numéro
Panneau 3 sections. Viseur à 2+4 chiffres. Commande avec fil.

Ref.	Medidas Size Dimensions	Altura dígitos (cm) Digits height (cm) Hauteur chiffres (cm)	Voltaje (V) Voltage (V) Voltage (V)
IT-30	54 x 40 cm	12,5 + 9,5	220



Indicador de turno
Panel de 3 secciones. Visor 2+4 dígitos. Mando a distancia.

Queue indicator
 Panel 3 secciones. 2+4 digit screen. Remote control.

Panel 3 sections. Viseur à 2+4 chiffres. Commande à distance.

Ref.	Medidas Size Dimensions	Altura dígitos (cm) Digits height (cm) Hauteur chiffres (cm)	Voltaje (V) Voltage (V) Voltage (V)
IT-30-MD	54 x 40 cm	12,5 x 9,5	220

INDICADOR TEMPERATURA | TEMPERATURE WARNING | INDICATEUR DE TEMPÉRATURE



Panel temperatura / humedad
Dígitos 9,5 cm

Temperature warning
 Temperature / humidity noticeboard. Digits 9,5 cm

Indicateur de température
Tableau de température / humidité. Chiffres 9,5 cm.

Ref.	Medidas Size Dimensions
ITH-95	7 x 32 x 48 cm



Reloj - temperatura
Carcasa metálica. 4 dígitos 12,5 rojos. Mando a distancia

Clock - temperature
 Metal housing. 4 red digits 12.5. Remote control

Horloge - température
Boîtier en métal. 4 chiffres rouges 12.5. Télécommande

Ref.	Medidas Size Dimensions
ITR-125	63,5 x 30,5 cm



Columna epoxi negro para expendedor ET-1 no incluido. Incluye cartel.

Black epoxy stand for ET-1 ticket dispenser

Colonne époxy noir pour dispensateur ET-1

Ref.	Altura (cm) Height (cm) Hauteur (cm)
ET-15	136 cms



Expendedor impresora térmica Ticket hasta 4 secciones

Thermal printer dispenser
Ticket up to 4 sections

*Dispensateur d'imprimante thermique
Ticket jusqu'à 4 sections*

Ref.
ET-100



Columna acero inoxidable para expendedor ET-1 no incluido.

Stainless steel column for dispenser ET-1 not included.

Colonne en acier inoxydable pour distributeur ET-1 non inclus.

Ref.	Altura (cm) Height (cm) Hauteur (cm)
ET-10	135 cms



Soporte pie expendedor ET-100

Food stand dispenser ET-100

Support pied dispensateur ET-100

Ref.
ET-100-S

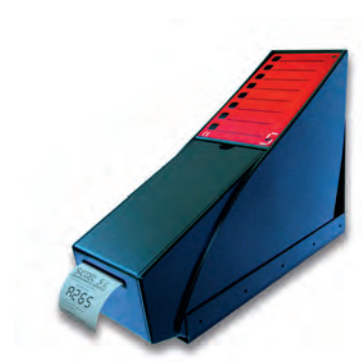

Soporte pared expendedor ET-100

Wall stand dispenser ET-100

Support mural dispensateur ET-100

Ref.
ET-100-P



Expendedor de tickets

Ticket dispenser

Dispensateur tickets

Ref.	Color Colour Couleur
ET-1-A	●
ET-1-AZ	●
ET-1-B	○
ET-1-G	●
ET-1-N	●
ET-1-NA	●
ET-1-R	●
ET-1-V	●

Rollos tickets dos dígitos (2000 números)

Two digits tickets rolls (2000 numbers)

Rouleaux de tickets deux chiffres (2000 numéros)

Ref.	Color Colour Couleur	Unidades Units Unités
RT-5-A	●	10
RT-5-AZ	●	10
RT-5-B	○	10
RT-5-R	●	10
RT-5-V	●	10

Rollos de tickets tres dígitos (2000 números)

Three digit ticket roll (2000 numbers)

Rouleaux de tickets (2000 numéros)

Ref.	Color Colour Couleur	Unidades Units Unités
RT-6-A	●	10
RT-6-AZ	●	10
RT-6-B	○	10
RT-6-R	●	10
RT-6-V	●	10

ORGANIZADOR DE FILAS | ROW ORGANIZER | ORGANISATEUR DE RANG



Postes acero inoxidable pintado negro con cinta extensible 2 metros

Black painted stainless steel posts with extensible strap 2 meters

Poteaux en acier inoxydable peint en noir avec sangle extensible 2 mètres

Ref.	Color Colour Couleur	Medidas Size Dimensions	Unidades Units Unités
OR-2	●●●	32 x 90 cm	pack 2 UND

Otros colores consultar.
Consult other colors.
Consultez d'autres couleurs.



Banda mural acero inoxidable pintado negro con cinta extensible 2 metros

Black painted stainless steel wall band with tape extendable 2 meters

Bande murale en acier inoxydable peint en noir avec du ruban adhésif extensible 2 mètres

Ref.	Color Colour Couleur
OR-2M	●●●

Otros colores consultar.
Consult other colors.
Consultez d'autres couleurs.



Exterminador de insectos
Posición suspendido ó sobre su base, material de policarbonato.

Electric insect exterminator
 Positioning hanging or standing on its base, material a polycarbonate.

Exterminateur d'insectes décharge électrique
Pose suspendu ou sur sa base, matériel polycarbonate.

Ref.	Medidas Size Dimensions	Voltaje Voltage Voltage	Tensión reja (V) Grid voltage (V) Tension grille (V)	Tubo luz actínica Actinic light tube Tube éclairage actinique	Superficie máxima (m²) Tube maximum surface (m²) Surface maximum (m²)
Z-151	13 x 16 x 34,5 cm	220 V 50Hz	4000	1 x 11W	110



Exterminador de insectos por descarga eléctrica
Con mando a distancia, posición suspendido ó sobre su base, material ABS-Aluminio.

Electric insect killer
 With remote control, positioning can hang on wall or stand on its base, material ABS-Aluminium.

Exterminateur d'insectes décharge électrique
Avec télécommande, pose suspendu ou sur sa base, matériel ABS-Alumin.

Ref.	Medidas Size Dimensions	Voltaje Voltage Voltage	Tensión reja (V) Grid voltage (V) Tension grille (V)	Tubo luz actínica Actinic light tube Tube éclairage actinique	Superficie máxima (m²) Tube maximum surface (m²) Surface maximum (m²)
Z-420-MD	39 x 30 x 10 cm	220-240 V	2000	2 x 10 W	300
Z-430-MD	49 x 34 x 10 cm	220-240 V 50 HZ	2000	2 x 15W	380
Z-440-MD	64 x 39 x 10 cm	220-240 V 50 HZ	2000	2 x 20W	451

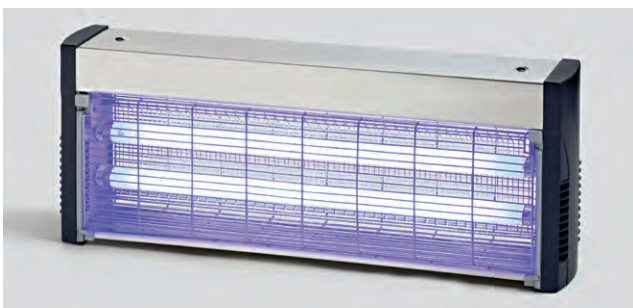

Exterminador de insectos
Posición suspendido ó sobre su base, material acero-inox.

Insect exterminator
 Positioning can hang on wall or stand on its base, material stainless steel.

Exterminateur d'insectes
Pose suspendu ou sur sa base, matériel acier-inox.

Ref.	Medidas Size Dimensions	Voltaje Voltage Voltage	Tensión reja (V) Grid voltage (V) Tension grille (V)	Tubo luz actínica Actinic light tube Tube éclairage actinique	Superficie máxima (m²) Tube maximum surface (m²) Surface maximum (m²)
Z-600	30 x 28 x 14 cm	220V 50/60Hz	2310V	2 x 11 W	300
Z-700	57 x 28 x 14 cm	220V 50/60Hz	5650	2 x 15W	380
Z-780	69 x 28 x 14 cm	220 V	4000	2 x 40W	600

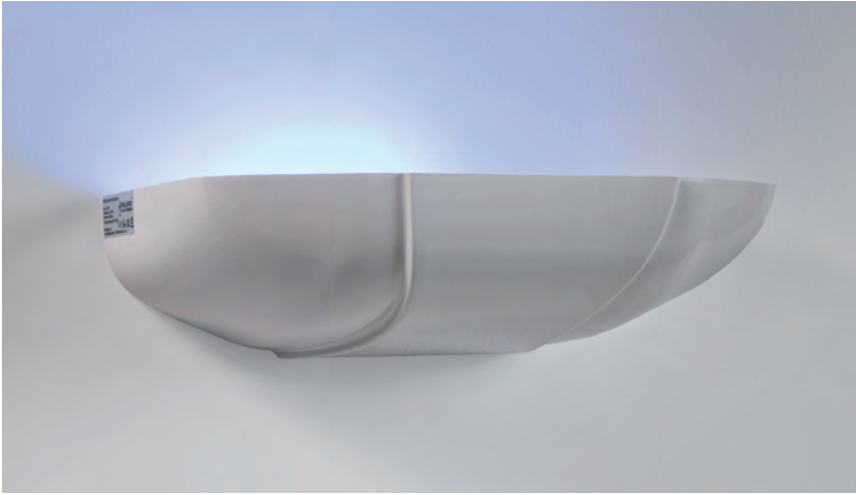

Trampa adhesiva
Para ref. Z-911. Paquete 6 unidades

Adhesive trap
For ref. Z-911. Pack 6 units

Piège adhésif
Pour réf. Z-911. 6 unités

Ref.	Unidades Units Unités
Z-911-A	6

Exterminador de insectos con trampa adhesiva
Lámpara 1x20 W bajo consumo, ABS blanco

Adhesive insect trap
Lamp 1x20 V, low energy, white ABS

Exterminateur d'insectes piège adhésif
Lampe 1x20 W, basse consommation, ABS blanc

Ref.	Color Colour Couleur	Medidas Size Dimensions	Voltaje Voltage Voltage	Lámpara luz actínica Actinic light lamp Lampe éclairage actinique
Z-911	○	49 x 19,7 x 10 cm	220 V	1 x 20 W
Z-911-N	●	49 x 19,7 x 10 cm	220 V	1 x 20 W

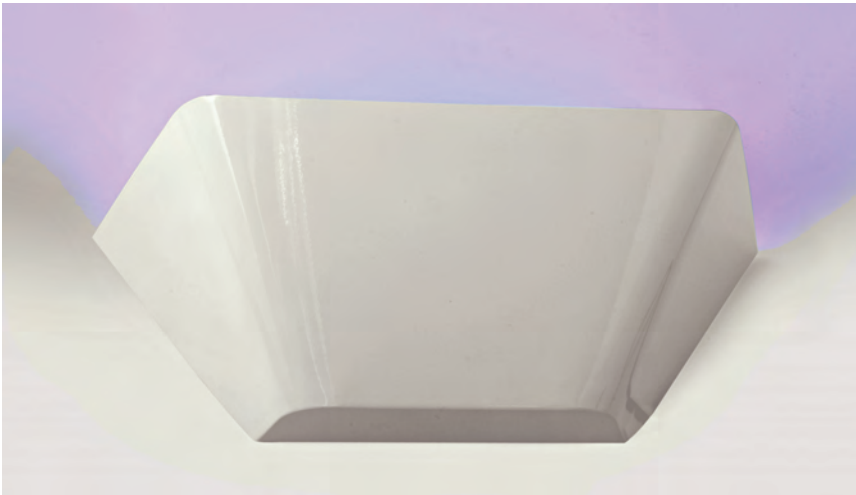

Lamina adhesiva
Para ref. Z-918. Paquete 6 unidades

Adhesive replacement
For Ref. Z-918, pack 6 units

Rechange adhésif
Pour réf. Z-918.

Ref.	Unidades Units Unités
Z-918-A	6

Exterminador de insectos con trampa adhesiva
Posición pared (aplique), material metálico Epoxi.

Recambio adhesiva : ref. Z-918-A

Adhesive insect trap
Positioning wall light, material metallic epoxy.

Adhesive replacement : ref. Z-918-A

Exterminateur d'insectes piège adhésif
Pose mur (applique), matériel métalloque époxy.

Rechange adhésif : réf. Z-918-A

Ref.	Color Colour Couleur	Medidas Size Dimensions	Voltaje Voltage Voltage	Lámpara luz actínica Actinic light lamp Lampe éclairage actinique
Z-918	○	45,5 x 18,7 x 15,5 cm	220 V	1 x 20W
Z-918-N	●	45,5 x 18,7 x 15,5 cm	220	1 x 20W

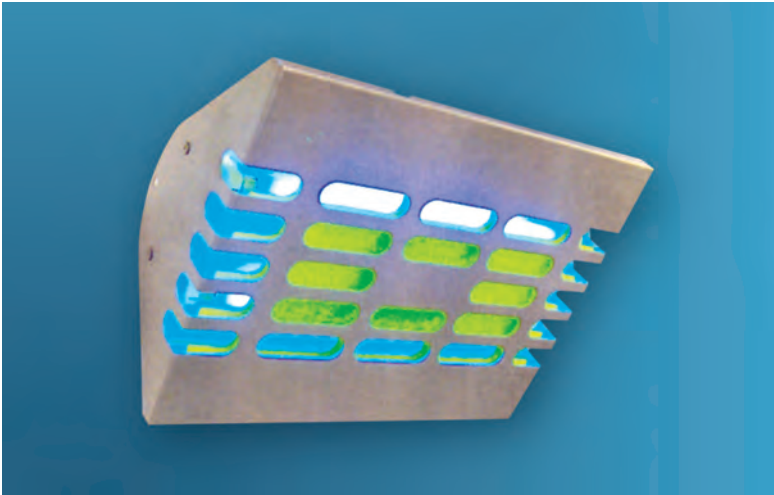

Exterminador de insectos con trampa adhesiva
Posición suspendido pared, material acero-inox.

Recambio adhesiva : ref. Z-950-A

Adhesive insect trap
 Positioning hung on wall, material stainless steel.

Adhesive replacement : ref. Z-950-A

Exterminateur d'insectes piège adhésif
Pose suspendu mur, matériel acier-inox.

Rechange adhésif : réf. Z-950-A

Ref.	Medidas Size Dimensions	Voltaje Voltage Voltage	Tubo luz actínica Actinic light tube Tube éclairage actinique
Z-950	47 x 35,5 x 18,5 cm	220	2 x 15W

Lamina adhesiva
Para ref. Z-950/Z-955. Paquete 6 unidades

Adhesive replacement
 For ref. Z-960. Pack 6 units

Réchange adhésif
Pour ref. Z-960-A. 6 unités.

Ref.	Unidades Units Unités
Z-950-A	6



Exterminador de insectos con trampa adhesiva.
Estanco IP65. Para ambientes con alto nivel de humedad. Posición suspendido, material acero-inox.

Recambio adhesivo: ref. Z-960-A

Adhesive insect trap.
 Waterproof. Suitable to work under high humidity ambient. Hung position. Stainless Steel made.

Adhesive replacement: ref. Z-960-A

Exterminateur d'insectes piège adhésif
Imperméable. Adéquat pour fonctionner dans ambient avec haut humidité. Position suspendu.
Fabriqué en acier inoxydable.
Réchange adhésif: réf. Z-960-A

Ref.	Medidas Size Dimensions	Voltaje Voltage Voltage	Tubo luz actínica Actinic light tube Tube éclairage actinique
Z-960	67 x 32,5 x 18,5 cm	220	2 x 20 W

Lamina adhesiva
Para ref. Z-960. Paquete 6 unidades

Adhesive replacement
 For ref. Z-960-A. Pack 6 units

Réchange adhésif
Pour ref.Z-960-A. 6 unités

Ref.	Unidades Units Unités
Z-960-A	6

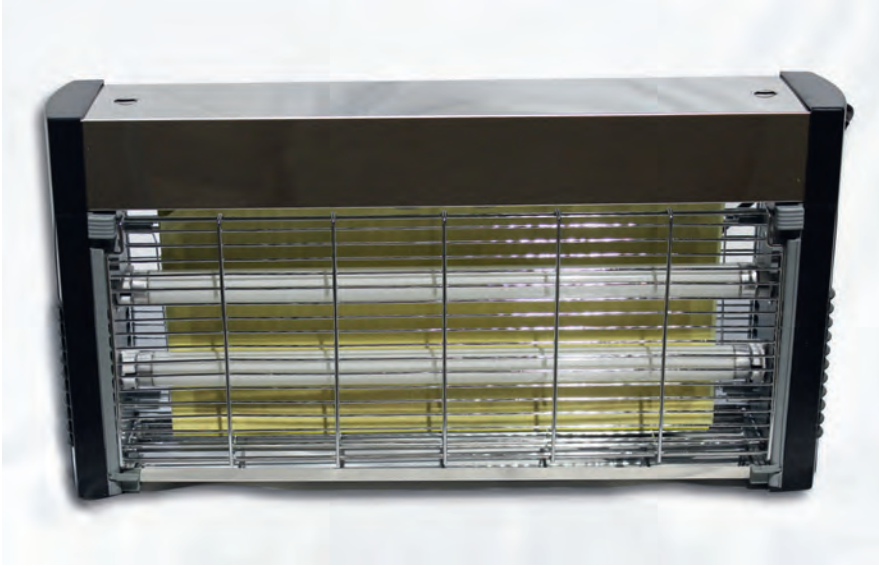

**Lamina adhesiva
Para ref. Z-930. Paquete 6 unidades**

Adhesive replacement
For ref. Z-940. Pack 6 units

Réchange adhésif
Pour ref. Z-940. 6 unités.

Ref.	Unidades Units Unités
Z-930-A	6

**Exterminador de insectos con trampa adhesiva dos caras.
Acabado acero inox / ABS**

Posición suspendido o sobre su base

Recambio adhesivo: Z-930-A

Insect exterminator with two-sided adhesive trap.
Stainless steel / ABS made

Position suspended or on its base

Adhesive refill: Z-930-A

Exterminateur d'insectes avec piège adhésif double face.
Fabriqué en acier inoxydable / ABS

Position suspendue ou sur son socle

Recharge adhésive: Z-930-A

Ref.	Medidas Size Dimensions	Voltaje Voltage Voltage	Tubo luz actínica Actinic light tube Tube éclairage actinique
Z-930	57 x 28 x 14 cm	220	2 x 15W

DETECTOR CONTADOR BILLETES - MONEDAS | COUNTER DETECTOR BILL - COIN | COMPTEUR DÉTECTEUR BILLETS - MONNAIE



Detector de billetes electrónico arrastre automático, batería

Electronic note detector with automatic drag / détecteur, batterie

Détecteur de billets électronique avec déplacement automatique,
batterie

Ref.	Voltaje (V) Voltage (V) Voltage (V)
A-530	220 V

Detector de billetes electrónico arrastre automático

Electronic note detector with automatic drag

Détecteur de billets électronique avec déplacement automatique

Ref.	Voltaje (V) Voltage (V) Voltage (V)
A-531	220 V



Contador separador monedas EURO

Coin serter EURO

Compteur séparateur de monnaie EURO

Ref.	Voltaje (V) Voltage (V) Voltage (V)
A-540	220 V



Detector contador billetes distinto valor EURO

Counteur detecteur different value bill EURO

Compteur detecteur billets de valeur différente EURO

Ref.	Voltaje (V) Voltage (V) Voltage (V)
A-550	220 V



Detector contador billetes igual valor EURO

Counteur detecteur equal value bill EURO

Compteur detecteur billets du même valeur EURO

Ref.	Voltaje (V) Voltage (V) Voltage (V)
A-555	220 V



0

7

**Hamburgueseras, Papel celofán, Embutidoras,
Jamoneras, Jamonero rotatorio 360°, Ganchos,
Libradores, Pinzas, Molde brochetas,
Enternecedor carne, Malla y anillas elásticas,
Protector hueso, Termómetros.**

Hamburger presses, Cellophane foil, Sausage
filler, Jamoneras, Rotary Ham holder 360°,
Hooks, Scoops, Tongs, Brochette mold, Meat
tenderizer, Elastic mesh and rings, Bone
protector, Thermometer.

*Hachoirs, Papiers cellophane, Emboutisseuses,
Jamoneras, Support de jambon rotatif 360°,
Crochets, Pelles à main, Pincés, Moule brochettes,
Attendrisseur, Maille et anneaux élastiques,
Protecteur d'os, Thermomètre.*

135 - 148



Hamburguesera carcasa aluminio de 1 unidad ovalada 11x8

Aluminium hamburger press, 1 oval shaped unit 11x8

Hachoir carcasse aluminium pour 1 unité ovale 11x8

Ref.	Diámetro Diameter Diamètre
MH-1	OVAL 11 x 8 cm



Hamburguesera aluminio 1 unidad redonda 10 cm diámetro

Aluminium hamburger 1 unit rounded 13 cm diameter

Hachoir aluminium 1 unité ronde 10 cm diamètre

Ref.	Diámetro Diameter Diamètre
MH-1-R	Ø 10 cm



Hamburguesera carcasa aluminio de 2 unidades ovalada 11x8

Aluminium hamburger press, 2 oval shaped units 11x8

Hachoir carcasse aluminium pour 2 unités ovales 11x8

Ref.	Diámetro Diameter Diamètre
MH-2	OVAL 11 x 8 cm



Hamburguesera acero-inox de 2 unidades ovalada 11x8

Stainless steel hamburger press, 2 oval shaped units 11x8

Hachoir acier inox pour 2 unités ovale 11x8

Ref.	Diámetro Diameter Diamètre
MH-3	OVAL 11 X 8



Hamburguesera acero-inox de 4 unidades ovalada 11x8

Stainless steel hamburger 11x8

Hachoir acier inox pour 4 unités ovale 11x8

Ref.	Diámetro Diameter Diamètre
MH-4	OVAL 11 x 8 cm



Hamburguesera acero-inox 2 unidades redonda

Stainless steel hamburger press, 2 round units

Hachoir acier inox pour 2 unités rondes

Ref.	Diámetro Diameter Diamètre
MH-5	Ø 10 cm



Hamburguesera aluminio 2 unidades.

Aluminium hamburger press 2 units.

Hachoir aluminium 2 unités.

Ref.	Diámetro Diameter Diamètre
MH-8	Ø 10 cm



Máquina hamburgesas aluminio 2 unidades. Redonda 6,5 cm diámetro

Aluminum hamburger machine 2 round units 6,5 cm diameter

Machine à hamburger aluminium 2 unités ronde 6,5 cm diameter

Ref.	Diámetro Diameter Diamètre
MH-9	Ø 6,5 cm



Máquina hamburguesera semi-automática
Molde acero 1 unidad inox. Tipo papel celofán ref. PH-6. Contenedor para papel celofán incorporado. Funcionamiento: mediante brazo de mando que permite de modo sincronizado la compresión y extracción de la hamburguesa.

Semi-automatic hamburger press
 Round stainless steel mold for one unit.
 Cellophane foil type ref. PH-6. Features cellophane foil container. Working: move lever for synchronised compression and removal from the hamburger press.

Hachoir semi-automatique
 Moule en acier inox rond pour 1 unité. Type papier cellophane réf.: PH-6. Conteneur pour papier cellophane incorporé. Fonctionnement: au moyen d'un bras qui permet de façon synchronisée la compression et l'extraction du hamburger.

Ref.	Diámetro Diameter Diamètre
MH-10	Ø 10 cm



Maquina hamburguesera semi-automática
1 unidad en acero inox. Tipo papel celofán ref. PH-7. Características igual ref. MH-10

Semi-automatic hamburger press
 Single round stainless steel mold.
 Cellophane foil type PH- 7. Features sam as ref. MH-10

Hachoir semi-automatique
 1 moule en acier inox rond. Type papier cellophane réf PH-7. Même caractéristiques ref. MH-10

Ref.	Diámetro Diameter Diamètre
MH-13	Ø 13 cm



Maquina hamburguesera semi-automática
1 unidad en acero inox. redonda. Tipo papel celofán ref. PH-8. Características igual ref. MH-10

Semi-automatic hamburger press
 Single round stainless steel mold.
 Cellophane foil type PH- 8. Features sam as ref. MH-10

Hachoir semi-automatique
 1 moule en acier inox rond. Type papier cellophane réf PH-8. Même caractéristiques ref. MH-10

Ref.	Diámetro Diameter Diamètre
MH-15	Ø 15 cm



Hamburguesera 1 unidad

Hamburger press
 1 unit.

Hachoir 1 unité.

Ref.	Diámetro Diameter Diamètre
MH-6	Ø 13 cm



Hamburguesera 2 unidades.

Hamburger press
 2 units.

Hachoir 2 unités.

Ref.	Diámetro Diameter Diamètre
MH-7	Ø 13 cm

Molde 1 unidad redonda con expulsor hamburguesa ACERO-INOX.

1 unit round mould. Stainless steel.

Moule 1 unité ronde. Acier inoxydable.



Ref.	Diámetro Diameter Diamètre
MH-25	Ø 5 cm
MH-20	Ø 6,5 cm
MH-21	Ø 10 cm
MH-22	Ø 13 cm
MH-23	Ø 15 cm

Paquete papel celofán redondo BIODEGRADABLE Y COMPOSTABLE

Packet of round cellophane foil

Paquet papier cellophane rond

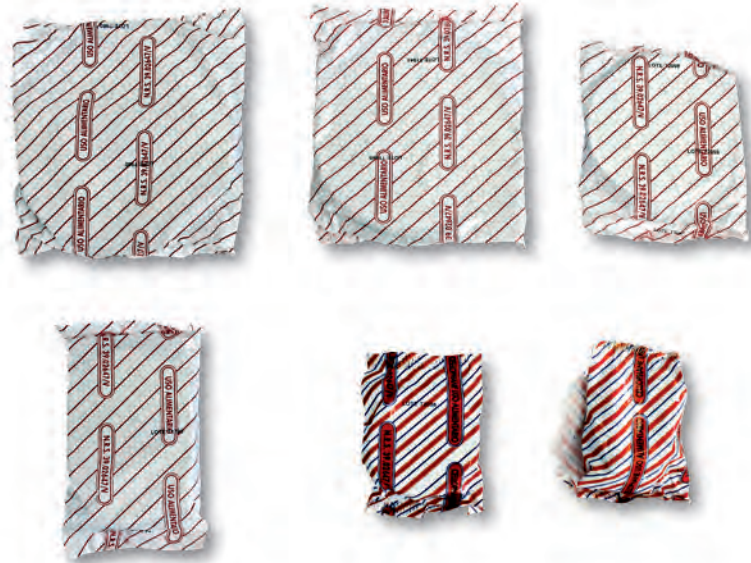

Ref.	Diámetro Diameter Diamètre	Unidades Units Unités
PH-3	Ø 5 cm	900
PH-4	Ø 6,5 cm	450
PH-6	Ø 10 cm	350
PH-5	OVAL 11 x 8 cm	450
PH-7	Ø 13 cm	350
PH-8	Ø 15 cm	350

Separador Interloncheados

Separator slices

Tranches de séparateur

Ref.	Medidas Size Dimensions	Unidades Units Unités
PS-60	160 x 60 mm	500
PS-70	160 x 70 mm	500
PS-80	160 x 80 mm	500



Embutidoras inox

Stainless steel sausage fillers

Emboutisseuses acier inoxydable

Ref.	Medidas Size Dimensions	Capacidad Capacity Capacité
ME-L5	55 x 19 x 21,5 cm	5 kg
ME-L8	65 x 19 x 21,5 cm	8 kg
ME-L8V	30 x 32 x 79 cm	8 kg

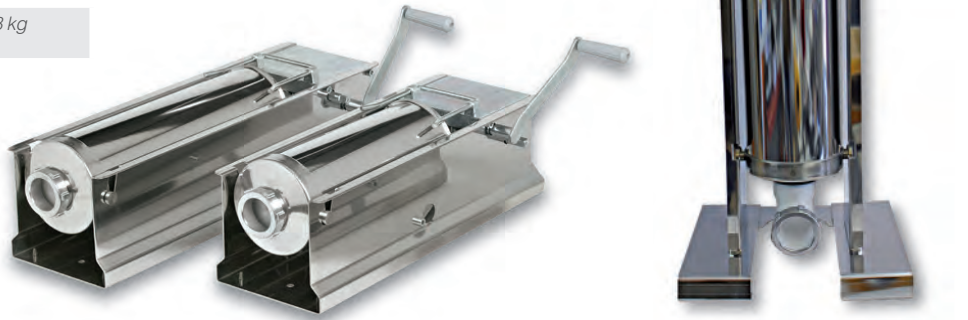

Embutidoras inox

Stainless steel sausage fillers

Emboutisseuses en acier inoxydable

Ref.	Medidas Size Dimensions	Peso Weight Poids	Capacidad Capacity Capacité
ME-L7	69 x 24 x 24 cm	27 kg	7 l
ME-L14	84 x 28 x 29 cm	35 kg	14 l



Despiece / Quartering / Dépeçage

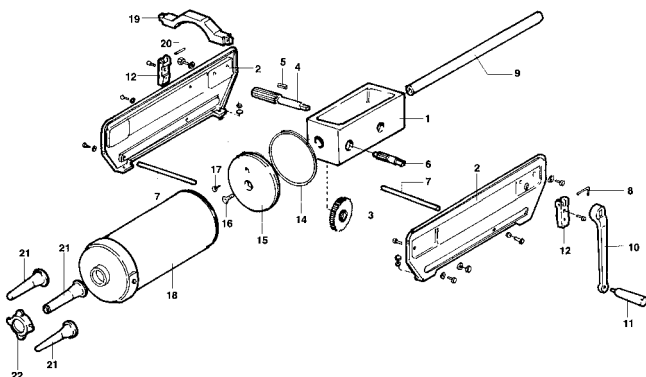

Medidas / Size / Dimensions

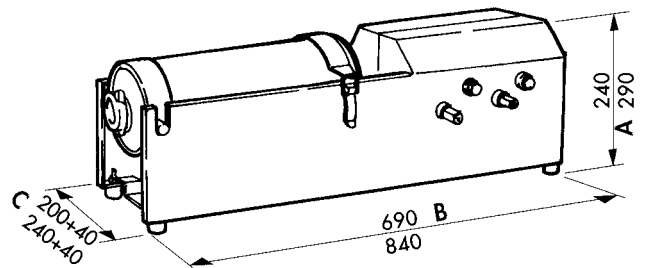

Juego 4 embudos inyección embutidora

Set of 4 injection filler funnels

Ensemble 4 entonnoirs injection emboutisseuses

Ref.

A-37





**Sujeta jamones
Rústico, base madera**

Ham holder
Rustic wooden base

*Présentoir jambons
Rustique base bois*

Ref.

SJ-4



**Sujeta jamón
Sobremesa o pared - base polietileno**

Ham holder
Free standing or fixed to wall - polyethylene base

*Serre-jambon
Sur table ou mur - base polyéthylène*

Ref.

SJ-5-M



**Sujeta jamones
Base y brazo polietileno blanco**

Ham holder
White polyethylene base

*Présentoir jambons
Base en polyéthylène blanche*

Ref.

SJ-6-B



**Sujeta jamones
Acero inox, soporte regulable**

Ham holder
Stainless steel fittable support

*Présentoir jambons
Inox. pied réglable*

Ref.

SJ-8



**Sujeta jamones
Fijo soporte madera**

Ham holder
Black removable arm, wooden base

*Présentoir jambons
Bras démontable bois, base bois*

Ref.

SJ-9



**Expositor jamones 20 unidades con
ruedas**

Wheel exhibitor ham 20 units

Présentoir jambons 20 unités avec roulettes

Ref.

SJ-20

Altura
Height
Hauteur

225 cm



**Sujeta jamones
Articulado giratorio inox base madera**

Ham holder
Articulated rotating inox base wood

*Présentoir jambons
Base articulée tournante inox, base en bois*

Ref.

SJ-10



Sujeta jamones giratorio inox con base madera.

Subject based steel rotating wooden ams

Acier à base de bois objet rotatif jambons

Ref.

SJ-15



**Sujeta jamones
Articulado giratorio 360° inox base polietileno negro**

Ham holder
Articulated rotating 360° inox base black polyethylene

*Présentoir jambons
Base articulée tournante 360° inox, base en polyéthylène noir*

Ref.

SJ-16



Sujeta jamones giratorio 360° inox base madera de encina

Subject based steel rotating 360° oak wooden ams

Acier à base de bois de chêne objet rotatif 360° pour jambons

Ref.

SJ-18



**Mesa jamonera con soporte jamón inox giratorio 360°
Encimera madera de encina con dos estantes**

Ham table with stainless rotary 360° ham holder
Oak wood countertop with two shelves

*Table jambon avec porte-jambon rotatif inox, 60 x 50 x 85 / 120
Comptoir en chêne avec deux tablettes*

Ref.

Medidas
Size
Dimensions

SJ-600

60 x 50 x 85 cm

**Mesa jamonera con soporte jamón inox giratorio 360°
Encimera madera de encina con dos estantes y dos ruedas giratorias con freno. Encimera madera de encina con dos estantes**

Ham table with stainless rotary 360° ham holder
Oak wood countertop with two shelves and two rotating wheels with brake

*Table jambon avec porte-jambon rotatif inox, 60 x 50 x 85 / 120
Comptoir en chêne avec deux tablettes et deux roues tournantes avec frein*

Ref.

Medidas
Size
Dimensions

SJ-600-R

60 x 50 x 85 cm

Mesa jamonera con soporte jamón inox giratorio

Ham table with stainless rotary ham holder

Table avec porte-jambon rotatif inox

Ref.

Medidas
Size
Dimensions

SJ-500

60 x 50 x 85 cm





Cono escurrejamonos

Ham drain cone

Cône égouttoir à jambon

Ref.	Unidades Units Unités
A-3	6



**Colgador jamones
12 unidades**

Ham hanger
12 units

*Porte jambons
12 unités*

Ref.
SJ-12



Cala jamón hueso de vaca

Ham piercer

Cale jambon

Ref.
A-27



Cala jamón mango madera

Ham piercer

Cale jambon

Ref.
A-28



Cala jamones bolígrafo

Ham piercer

Cale jambon

Ref.
A-29

GANCHOS ACERO-INOX | STAINLESS STEEL HOOKS | CROCHETS ACIER-INOX



Ganchos acero-inox

Stainless steel hooks

Crochets acier-inox

Ref.	Largo Long Longueur	Varilla Rod Tige	Unidades Units Unités
G-00	8 cm	4 mm	10
G-0	10 cm	4 mm	10
G-1	12 cm	5 mm	10
G-2	14 cm	5 mm	10
G-3	16 cm	5 mm	10
G-4	18 cm	5 mm	10

Ganchos acero-inox

Stainless steel hooks

Crochets acier-inox

Ref.	Largo Long Longueur	Varilla Rod Tige	Unidades Units Unités
G-5	20 cm	5 mm	10
G-6	22 cm	6 mm	10
G-7	20 cm	8 mm	10
G-8	30 cm	8 mm	10
G-9	18 cm	8 mm	10

Ganchos giratorio acero-inox

Stainless steel rotating hooks

Giratoire crochets acier-inox

Ref.	Largo Long Longueur	Varilla Rod Tige
G-10	25 cm	11 mm
G-11	30 cm	11 mm
G-12	25 cm	12 mm
G-13	30 cm	12 mm

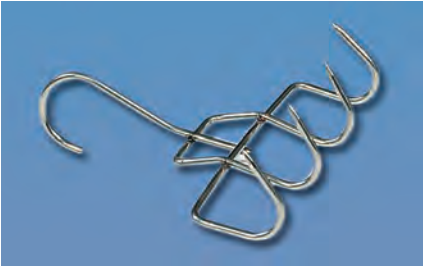

Gancho 4 puntas

4-spike hook

Crochet 4 pointes

Ref.

G-14



Gancho de pared

Wall hook

Crochet mural

Ref.

Medidas
Size
Dimensions

G-18

120 x 10

G-19

120 x 12



Gancho salchichero giratorio de 22 cms de altura con 4 brazos de 10 cms.

Revolving sausage hook of 22 cms height with 10 cms arms

Crochet à saucisses giratoire de 22 cms d'hauteur avec 4 bras de 10 cms

Ref.

G-15

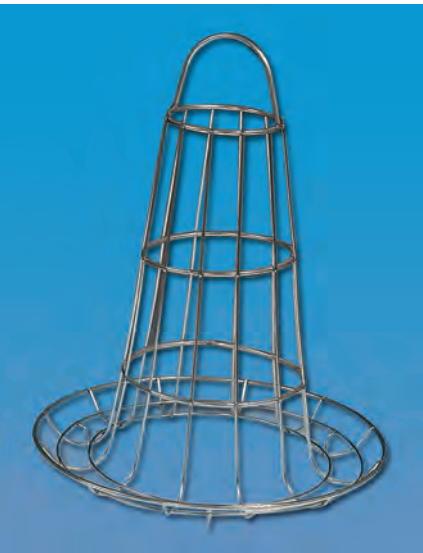

Torre pirámide salchichera

Pyramid sausage tower

Tour pyramide à saucisses

Ref.

Altura
Height
Hauteur

Diámetro
Diameter
Diamètre

G-20

39 cm

Ø 28 cm



Librador-cogedor, inox

Stainless steel scoops

Pellesà main, inox

Ref.	Medidas Size Dimensions
A-5-12	21 / 12 x 6 cm
A-5-16	25 / 16 x 9 cm
A-5-20	29 / 18 x 10 cm
A-5-24	31 / 20 x 11 cm



Librador - cogedor inyectado

Plastic scoop

Pelle à main, plastique

Ref.	Medidas Size Dimensions
A-4-11	18 / 12 x 6 cm
A-4-14	24 / 16 x 8 cm
A-4-16	28 / 19 x 10 cm
A-4-20	33 / 22 x 11 cm
A-4-24	38 / 26 x 13 cm

PINZAS, PORTA ROLLS, SOPORTE TICKETS | TONGS, ROLL HOLDERS, TICKET HOLDER | PINCES, PORTE ROLEAUX, SUPPORT TICKET



Pinza acero inox con muelle

Stainless steel tong with spring

Pince acier inox avec ressort

Ref.
A-8



Pinza acero inox. para embutido

Stainless steel tong for cold meats

Pince acier inox pour charcuterie

Ref.
A-20



Pinza acero inox espina pescado

Stainless steel tong for fish bone

Pince acier inox arête poisson

Ref.
A-23



Pinza acero inox

Stainless steel tong

Pince acier inox

Ref.	Largo Long Longueur
A-24	24 cm



Pinza acero-inox con anillas

Stainless steel tong with rings

Pince acier inox avec anneaux

Ref.
A-26



Porta-notas acer-inox, 60 cm con bolitas

Stainless steel note holder 60 cm, little balls system

Porte-notes acier inox 60 cm, système boules

Ref.
T-360



Soposte para pinchar tickets

Ticket holder

Support pour piquer les tickets

Ref.

PR-25



Porta rollo hilo

Thread roll holder

Porte rouleau fil

Ref.

PR-20

MÁQUINA MANUAL PINCHOS | MANUAL BROCHETTE MAKER | MACHINE MANUELLE POUR BROCHETTES

Máquina manual pinchos acero inox 2 unidades

Stainless steel maual brochette maker 2 units

Machine manuelle inox. pour brochettes 2 unités

Ref.

A-49



MOLDE BROCHETAS. PALILLOS | BROCHETTE MOLD. SKEEWERS | MOULE BROCHETTES. BROCHETTES



Molde brochetas polietileno para 25 unidades

Brochette polyethylene mold 25 units

Moule brochettes de polyéthylène

Ref.

A-50

Medidas
Size
Dimensions

16,5 x 16,5 x 31 cm



Palillos

Skewers

Brochette

Ref.	Largo Long Longueur	Unidades Units Unités
A-50-15	15 cm	200
A-50-25	25 cm	100
A-50-30	30 cm	100



Enternecedor carne minibla

Meat tenderizer

Attendrisseur manuel

Ref.

A-15

MALLA Y ANILLAS ELÁSTICAS | ELASTIC MESH AND RINGS | MAILLE ET ANNEAUX ÉLASTIQUES



Malla elástica. Máximo 175º

Elastic mesh. Maximum 175º

Maille élastique. Maximum 175º

Ref.	Tipo Type	Largo Long Longueur
H-12SR	12	50 m
H-14SR	14	50 m
H-16SR	16	50 m
H-18SR	18	50 m
H-20SR	20	50 m

Ref.	Tipo Type	Largo Long Longueur
H-22R	22	50 m
H-24R	24	50 m
H-26R	26	50 m
H-28R	28	50 m



Anillas elásticas

Elastic rings

Anneaux élastiques

Ref.	Tipo Type	Peso Weight Poids
H-120NV	120	3 kg
H-140NV	140	3 kg

TUBO PLÁSTICO | PLASTIC TUBE | TUBE EN PLASTIQUE



Tubo plastico naranja

Orange plastic tube

Orange tube en plastique

Ref.	Tipo Type
H-E10	10/86
H-E12	12/92
H-E14	14/110
H-E16	16/125
H-E18	18/140





Protector hueso

Bone protector

Protecteur d'os

Ref.	Tipo Type	Largo Long Longueur
H-P23	23	100 m
H-P33	33	100 m

Protector hueso pre-corte 7,5

Precut 7,5 bone protector

Protecteur 7,5 hueso pre-corte

Ref.	Tipo Type	Largo Long Longueur
H-P23-C	23	100 m
H-P33-C	33	100 m

TERMOMETROS | THERMOMETERS | THERMOMÈTRES |



Termómetro para Frigorífico o Congelador vertical (-50+50°)

Vertical Thermometer for Refrigerator or Freezer (-50 + 50°)

Thermomètre vertical pour réfrigérateur ou congélateur (-50 + 50°)

Ref.

T-002



Termómetro Digital Horno con Sonda (0-300°)

Digital Thermometer Oven with Probe (0-300°)

Thermomètre numérique Four avec sonde (0-300°)

Ref.

T-003



Termometro Asado con Pincho (+55+88°)

Roast Thermometer with Pin (+55+88°)

Thermomètre Rôti avec Pique (+55+88°)

Ref.

T-005



Termometro Aceite con Gancho (0-300°)

Oil Thermometer with Hook (0-300°)

Thermomètre à huile avec crochet (0-300°)

Ref.

T-007



Termómetro Digital para Frigorífico o Congelador con Sonda (-50-70°)

Digital Thermometer for Refrigerator or Freezer with Probe (-50-70°)

Thermomètre numérique pour réfrigérateur ou congélateur avec sonde (-50-70°)

Ref.

T-009



Termómetro Laser de bolsillo (-50+300°)

Pocket-Size Laser Thermometer (-50 + 300°)

Thermomètre à laser de poche (-50 + 300°)

Ref.

T-012



Termómetro laser modelo Extra (-50+280°)

Laser thermometer Extra model (-50 + 280°)

Thermomètre laser modèle supplémentaire (-50 + 280°)

Ref.

T-008



Termómetro Frigorífico (-50 +50°)

Refrigerator Thermometer (-50 + 50°)

Thermomètre de réfrigérateur (-50 + 50°)

Ref.

T-050

Testador de Aceite (Pack 10 und.)

Oil Tester (Pack 10 units.)

Testeur d'huile (Pack 10 unités)

Ref.

TA-002



0

8

**Cierra bolsas - rollos, Etiquetadoras-rollos,
Naveteadoras, Espejos vigilancia, Carro servicio
- Bandejero, Cestos - carros autoservicio,
Dispensadores bolsas, Carros Gastronorm.**

Bag-roll sealer, Labellers-rolls, Labelling gun,
Vigilance mirror, Service trolley - tray, Self-service
basket - trolley, Bags dispensers, Gastronorm
trolley.

*Machines ferme sacs, Étiquetteuses-rolls,
Pistolet à étiqueter, Miroir de surveillance, Chariot
service - Plateau, Panier - chariot self-service,
Dispensateurs sacs, Chariot Gastronorm.*

149 - 160



Máquina cierra bolsas plástico blanco

Bag sealer white plastic

Machine pour fermer les sacs plastique blanc

Ref.

CB-606



**Máquina cierra bolsas acero inox
Con cuchilla para cortar bolsa**

Bag sealer stainless steel
With bag cutter blade

*Machine pour fermer les sacs acier inox
Avec lame pour couper le sac*

Ref.

CB-101



Rollo de PVC 66 x 12

PVC Rolls 66 x 12

Rouleaux PVC 66 x 12

Ref.	Color Colour Couleur	Unidades Units Unités
RB-4-B	○	24
RB-4-A	●	24
RB-4-AZ	●	24
RB-4-R	●	24
RB-4-V	●	24
RB-4-T	⊙	24



Dispensador celo inyección para referencias RB-4

Cello tape dispenser injection for references RB-4

Distributeur scotch injection pour références RB-4

Ref.

CB-800

ETIQUETADORAS | LABELLERS | ÉTIQUETTEUSES



Etiquetadora una línea 8 dígitos

Labeller 1 line 8 digits

Étiquetteuse 1 ligne chiffres

Ref.

E-4



Etiquetadora una línea 6 dígitos

Labeller 1 line 6 digits

Étiquetteuse 1 ligne 6 chiffres

Ref.

E-5



Etiquetadora una línea 6 dígitos

Labeller 1 line 6 digits

Étiquetteuse 1 ligne 6 chiffres

Ref.

E-5-ECO



Etiquetadora dos líneas 8 dígitos

Labeller 2 line 8 digits

Étiquetteuse 2 lignes 8 chiffres

Ref.

E-6



Etiquetadora dos líneas 8 dígitos

Labeller 2 line 8 digits

Étiquetteuse 2 ligne 8 chiffres

Ref.

E-6-ECO

Rodillo tinta

Ink roller

Rouleau encre

Ref.

Para For Pour

E-110

E-4, E-5, E-6

Rodillo tinta

Ink roller

Rouleau encre

Ref.

Para For Pour

E-110-ECO

E-5-ECO, E-6-ECO

ROLLOS ETIQUETADORAS | LABELLERS | ÉTIQUETTEUSES



Rollos etiquetas

Label rolls

Rouleaux d'etiquettes

Ref.	Medidas Size Dimensions	Color Colour Couleur	Tipo Type Type	Unidades Units Unités
RE-5-B	26 x 12 mm	○	1	8
RE-5-N	26 x 12 mm	●	1	8
RE-6-B	26 x 16 mm	○	2	8
RE-6-N	26 x 16 cm	●	2	8

Rollo etiquetas dos líneas lote-caducidad

Label rolls 2 lines expiry date

Labell rolls 2 lines date de péremtion

Rollos etiquetas dos líneas fecha envasado-fecha caducidad

Label rolls 2 lines packaging date and expiry date

Rouleaux d'etiquettes 2 lignes date d'envasado et péremtion

Ref.	Medidas Size Dimensions	Unidades Units Unités	Ref.	Medidas Size Dimensions	Unidades Units Unités
RE-7	26 x 16 mm	8	RE-8	26 x 16 mm	8

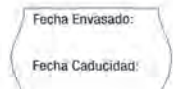



Naveteadora Dennison homologada

Labelling gun Dennison approved

Pistolet à étiquetter Dennison homologué

Ref.

N-3



Navet cárnico standard 25 mm caja 10.000 unidades

Standard meat tag 25 mm

Étiquetteuse à viande standard 25 mm

Ref.

N-21

Unidades
Units
Unités

10000



Naveteadora Arrow standard

Labelling gun Arrow standard

Pistolet à étiqueter Arrow standard

Ref.

N-9



Naveteadora P.P. blanco caja 5.000 unidades

White P.P. tag 40 mm

Étiquetteuse P.P. blanc 40 mm

Ref.

N-22

Unidades
Units
Unités

5000

Navet cárnico homologado 25 mm caja 5000 unidades

Approved meat tag 25 mm

Étiquetteuse à viande homologuée 25 mm

Ref.

N-20

Unidades
Units
Unités

5000

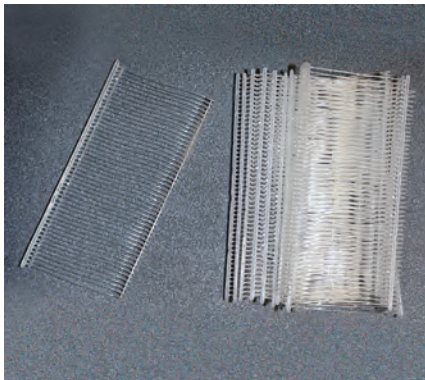

Aguja Dennison standard 5 unidades

Standard meat pin Dennison 5 units

Aiguille à viande Dennison standard 5 unités

Ref.

N-30

Unidades
Units
Unités

5

Aguja Dennison homologada 5 unidades

Standard meat pin Dennison 5 units

Aiguille à viande Denisson standard 5 unités

Ref.

N-31

Unidades
Units
Unités

5

Aguja arrow standard 5 unidades

Standard meat pin arrow 5 units

Aiguille à viande arrow standard 5 unités

Ref.

N-32

Unidades
Units
Unités

5



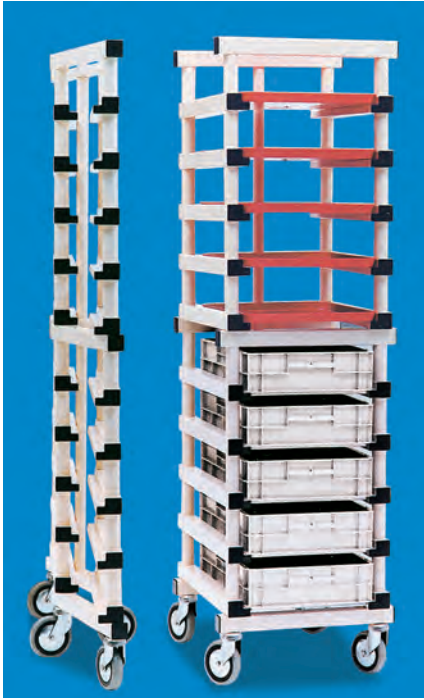

Carro bandejero plegable
Plegable: 10 guías. 2 ruedas giratorias. 2 ruedas giratorias con stop. Ruedas cincadas. Ideal para bandeja BI-15 ó cubeta CC-9/19/21

Foldable tray trolley
 Foldable: 10 rails. 2 swivel wheels. Wheels: zinc coated. Ideal for BI-15 tray or CC-9/19/21 deep tray

Chariot à plateaux-bacs plian
 Pliant: 10 guides. 2 roulettes giratoires. 2 roulettes giratoires avec stop. Roulettes: zinguées. Idéal pour plateau BI-15 ou cuvette CC-9/19/21

Ref.	Medidas Size Dimensions	Color Colour Couleur
R-10-G	54 x 65 x 179 cm	●
R-10-BE	54 x 65 x 179 cm	○

Carro bandejero plegable
Plegable: 10 guías. 2 ruedas giratorias. 2 ruedas giratorias con stop. Ruedas poliamida. Ideal para bandeja BI-15 ó cubeta CC-9/19/21

Foldable tray trolley
 Foldable: 10 rails. 2 swivel wheels. Wheels: polyamide. Ideal for BI-15 tray or CC-9/19/21 deep tray

Chariot à plateaux-bacs plian
 Pliant: 10 guides. 2 roulettes giratoires. 2 roulettes giratoires avec stop. Roulettes: polyamide. Idéal pour plateau BI-15 ou cuvette CC-9/19/21

Ref.	Medidas Size Dimensions	Color Colour Couleur
R-10-GP	54 x 65 x 179 cm	●
R-10-BEP	54 x 65 x 179 cm	○



Carro bandejero inox Tipo 60 x 40
20 guías. 2 ruedas giratorias. 2 ruedas giratorias con stop. Incluido ruedas. Embalaje desmontado. Ideal para bandeja BI-15

Stainless steel tray trolley Type 60 x 40
 20 rails. 2 swivel wheels. Wheels included. Packaged disassembled. Ideal for BI-15 tray

Chariot à plateaux-bacs inox Type 60 x 40
 20 guides. 2 roulettes giratoires. 2 roulettes giratoires avec stop. Compris roulettes. Emballage démonté. Idéal pour plateau BI-15

Ref.	Medidas Size Dimensions
R-20	46,5 x 63 x 186 cm

Carro bandejero inox 1/1
20 guías. 2 ruedas giratorias. 2 ruedas giratorias con stop. Incluido ruedas. Embalaje desmontado. Ideal para bandeja BI-15

Stainless steel tray trolley 1/1
 20 rails. 2 swivel wheels. Wheels included. Packaged disassembled. Ideal for BI-15 tray

Chariot à plateaux-bacs inox 1/1
 20 guides. 2 roulettes giratoires. 2 roulettes giratoires avec stop. Compris roulettes. Emballage démonté. Idéal pour plateau BI-15

Ref.	Medidas Size Dimensions
R-21	38 x 55 x 186 cm

Carro bandejero inox 2/1
20 guías. 2 ruedas giratorias. 2 ruedas giratorias con stop. Incluido ruedas. Embalaje desmontado.

Stainless steel tray trolley 2/1
 20 rails. 2 swivel wheels. Wheels included. Packaged disassembled.

Chariot à plateaux-bacs inox 2/1
 20 guides. 2 roulettes giratoires. 2 roulettes giratoires avec stop. Compris roulettes. Emballage démonté.

Ref.	Medidas Size Dimensions
R-22	58,5 x 67,5 x 186 cm

Bandejas ABS para carros R-10/R-20

ABS tray

Plateau ABS



Ref.	Medidas Size Dimensions	Color Colour Couleur
BI-15-B	58,5 x 41 x 2,5 cm	○
BI-15-R	58,5 x 41 x 2,5 cm	●
BI-15-N	58,5 x 41 x 2,5 cm	●

Bandejas Pasteleras Acero Inox. / Aluminio

Stainless steel / aluminum pastry trays



Ref.	Medidas Size Dimensions
BAC-1	60 x 40 x 1 cm
BAL-1	60 x 40 x 1 cm



**Carro de servicio, acero-inox
2 estanterías. Ruedas: 2 giratorias,
2 giratorias con stop. Embalaje:
desmontado. 40 kgs por estante**

Service trolley, stainless steel
2 Shelves. 2 revolving wheels, 2 revolving
wheels with brake. Package: disassembled.
40 kg per shelf

*Chariot service, acier inox
2 Étagères. Roulettes 2 giratoires, 2
giratoires avec stop. Embalage: démonté.
40 kilos par étagère*

Ref.	Medidas Size Dimensions
R-30	91 x 59 x 93 cm



**Carro de servicio, acero-inox
3 estanterías. Ruedas: 2 giratorias,
2 giratorias con stop. Embalaje:
desmontado. 40 kgs por estante**

Service trolley, stainless steel
3 Shelves. 2 revolving wheels, 2 revolving
wheels with brake. Package: disassembled
40 kg per shelf

*Chariot service, acier inox
3 Étagères. Roulettes 2 giratoires, 2
giratoires avec stop. Embalage: démonté
40 kilos par étagère*

Ref.	Medidas Size Dimensions
R-31	91 x 59 x 93 cm



Cesto un asa
Alta resistencia. Opciones: logotipos y/o otros colores : min. 720 unidades.

1-handle basket
High resistance. Options: logotypes and/or other colours: min 720 units

Panier 1 anses
Haute resistance. Optionnel: logotypes et/ou autres couleurs: min 720 unités

Ref.	Medidas Size Dimensions	Capacidad Capacity Capacité	Color Colour Couleur
R-2020-AZ	47 x 31 x 30 cm	28	●
R-2020-R	47 x 31 x 30 cm	28	●
R-2020-V	47 x 31 x 30 cm	28	●

R-2021 Carrito para apilar y mover R-2020

Piling and transport kart R-2020

Chariot pour empiler et déplacer R-2020



Cesto con 4 ruedas 2 fijas 2 giratorias
Asas abatibles

4-wheel basket with 2 fixed and 2 revolving wheels
Collapsible handles

Panier avec 4 roulettes 2 fixes 2 giratoires
Anses rabattables

Ref.	Medidas Size Dimensions	Color Colour Couleur	Capacidad Capacity Capacité
R-2032-AZ	50 x 34 x 36 cm	●	32 l
R-2032-R	50 x 34 x 36 cm	●	32 l
R-2032-V	50 x 34 x 36 cm	●	32 l



Cesto con 4 ruedas 2 fijas 2 giratorias
Asas abatibles

4-wheel basket with 2 fixed and 2 revolving wheels
Collapsible handles

Panier avec 4 roulettes 2 fixes
2 giratoires

Ref.	Medidas Size Dimensions	Color Colour Couleur	Capacidad Capacity Capacité
R-2054-AZ	55 x 39,5 x 44 cm	●	54 l
R-2054-R	55 x 39,5 x 44 cm	●	54 l
R-2054-V	55 x 39,5 x 44 cm	●	54 l



Cadena inicio

Start chain

Chaîne démarrage

Ref.

R-CI110

Porta-monedas

Coin box

Porte monnaie

Ref.

R-PM110

Carro autoservicio 80 l

80 l self-service trolley

Chariot self-service 80 l

Ref.	Medidas Size Dimensions	Capacidad Capacity Capacité
R-80	63 x 49,5 x 105 cm	80 l



Carro autoservicio 50 l

50 l self-service trolley

Chariot self-service 50 l

Ref.	Medidas Size Dimensions
R-50	57 x 47 x 91,5 cm



Carro autoservicio 75 l

75 l self-service trolley

Chariot self-service 75 l

Ref.	Medidas Size Dimensions
R-75	78 x 51 x 87,6 cm



Cadena inicio

Start chain

Chaîne démarrage

Ref.
R-CI



Carro autoservicio 100 l

100 l self-service trolley

Chariot self-service 100 l

Ref.	Medidas Size Dimensions
R-100	85,5 x 51,5 x 101 cm

Porta-monedas

Coin box

Porte monnaie

Ref.
R-PM

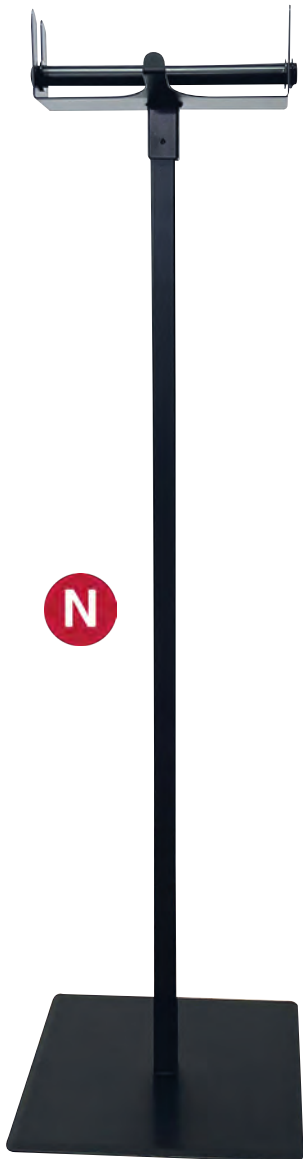

Dispensador con precorte para bolsas en rollo bio anchura 23 cm

Pre-cut dispenser for bio roll bags width 23 cm

Distributeur prédécoupé pour sacs bio roll largeur 23 cm

Ref.

MR-109-N

Soporte fijación pie 102 cm

Foot fixing support 102 cm

Support de fixation pied 102 cm

Ref.

MR-108-N



Soporte para bolsas de bloque

Bag roll block holder

Support pour sacs en bloc

Ref.

MR-110



Soporte fijación pared

Wall fixing bracket

Support de fixation murale

Ref.

MR-107-N



Dispensador porta guantes inox

Stainless steel glove dispenser for ref. W-12

Dispensateur porte-gants inox pour réf. W-12

Ref.

MR-104-I

Dispensador para bolsas en rollo de 500 unidades

Bag roll dispenser for MR-500 bags

Dispensateur pour sacs en rouleau réf. MR-500

Ref.

MR-103-I

Soporte de fijación inox. para réf. MR-103-I/104-I

Stainless steel support stand for ref MR-103-I/104-I

Support de fixation inox pour réf. MR-103-I/104-I

Ref.

MR-105-I

Dispensador inox 2 brazos para rollo bolsas

Stainless steel dispenser 2 arms for bags roller

Dispensateur acier inox 2 bras pour rouleau sacs

Ref.

MR-119-I



Soporte para bolsas de bloque acero inox

Support for stainless steel block bags

Support pour sacs de bloc acier inox

Ref.

MR-115-I

0

9

Cuchillería profesional, Afiladores, Chairas, Hachas, Tijeras, Espátulas, Bacaladera, Abre-Ostras, Sierras, Imanes, Guillotinas queso, Sacacorchos, Abrelatas, Guantes, Delantes, Material de un uso, Delantales protección, Guantes frío, Guantes malla acero-inox, Guantes y manoplas calor.

Professional knives, Sharpeners, Axes, Scissors, Spatulas, Fish shears, Oyster sucker, Saws, Magnets, Cheese guillotines, Corkscrew, Can openers, Gloves, Aprons, Disposable material, Protective aprons, Cold gloves, Mesh steel-stainless gloves, Gloves and mittens heat.

Coteaux professionnels, Aiguiseurs, Scies, Ciseaux, Spatules, Moorutiel manuel, Couteau à huitres, Scies, Aimants, Guillotines à fromage, Tire-Bouchon, Ouvre-Boîtes, Gants, Tabliers, Material d'un seul usage, Tabliers de protection, Gants froid, Gants en acier inoxydable, Gants et mitaines chaleur.



Cuchillo carnicero alveolado
Mango inyectado

Indented butcher's knife
Plastic handle

Couteau de boucher alvéolé
Manche en plastique

Ref.	Largo Long Longueur	Color Colour Couleur
0151.310	310 mm	● ● ● ● ● ●
0151.355	355 mm	● ● ● ● ● ●
0151.395	395 mm	● ● ● ● ● ●



Cuchillo carnicero
Mango inyectado

Butcher's knife
Plastic handle

Couteau de boucher
Manche en plastique

Ref.	Largo Long Longueur	Color Colour Couleur
0170.155	155 mm	● ● ● ● ● ●
0170.185	185 mm	● ● ● ● ● ●
0170.210	210 mm	● ● ● ● ● ●
0170.260	260 mm	● ● ● ● ● ●
0170.310	310 mm	● ● ● ● ● ●
0170.355	355 mm	● ● ● ● ● ●
0170.395	395 mm	●



Cuchillo degollar
Mango inyectado

Sticking knife
Plastic handle

Couteau à égorger
Manche en plastique

Ref.	Largo Long Longueur	Color Colour Couleur
0370.165	165 mm	●
0370.195	195 mm	●
0370.225	225 mm	●



Cuchillo deshuesar
Mango inyectado

Boning knife
Plastic handle

Couteau à désosser
Manche en plastique

Ref.	Largo Long Longueur	Color Colour Couleur
0425.130	130 mm	● ● ● ● ● ●
0425.150	150 mm	● ● ● ● ● ●



Cuchillo deshuesar, hoja curva
Mango inyectado

Boning knife, curve blade
Plastic handle

Couteau à désosser, lame courbe
Manche en plastique

Ref.	Largo Long Longueur	Color Colour Couleur
0430.150	150 cm	● ● ● ● ●



Cuchillo pescadero
Mango inyectado

Fish knife
Plastic handle

Couteau à poisson
Manche en plastique

Ref.	Largo Long Longueur	Color Colour Couleur
0701.320	320 mm	● ● ● ● ●
0701.350	350 mm	● ● ● ● ●
0701.370	370 mm	● ● ● ● ●



Cuchillo pescadero
L/vaca M/polietileno

Fish knife
Polyethylene handle

Couteau à poisson
Manche polyéthylène

Ref.	Largo Long Longueur	Color Colour Couleur
0720.350	350 mm	●
0720.380	380 mm	●



Cortante bacalao
Mango polietileno

Cod knife
Polyethylene handle

Couteau à morue
Manche polyéthylène

Ref.	Largo Long Longueur	Color Colour Couleur
0775.190	190 mm	●



Cuchillo jamonero
Mango polietileno. Hoja flexible

Ham knife
Polyethylene handle. Flexible blade

Couteau pour jambon
Manche polyéthylène. Lame flexible

Ref.	Largo Long Longueur	Color Colour Couleur
0500.305	305 mm	●



Cuchillo jamón
Mango inyectado

Ham knife
Plastic handle

Couteau pour jambon
Manche en plastique

Ref.	Largo Long Longueur	Color Colour Couleur
0526.250	250 mm	●
0526.300	300 mm	●



Cuchillo jamón
Hoja estrecha, mango polietileno

Ham knife
Narrow blade, polythylene handle

Couteau jambon
Lame étroite, manche polyéthylène

Ref.	Largo Long Longueur	Color Colour Couleur
0540.250	250 mm	●
0540.305	305 mm	●

Cuchillo jamonero
Mango polietileno. Hoja recia.

Ham knife
Polyethylene handle. Hard blade

Couteau pour jambon
Manche polyéthylène. Lame dure

Ref.	Largo Long Longueur	Color Colour Couleur
0521.250	250 mm	●

Cuchillo jamonero
Mango polietileno. Hoja recia.

Ham knife
Polyethylene handle. Hard blade

Couteau pour jambon
Manche polyéthylène. Lame dure

Ref.	Largo Long Longueur	Color Colour Couleur
0521.300	300 mm	●



Cuchillo cocinero forjado
Mango phenolkraff

Forged chef's knife
Phenolkraff handle

Couteau de cuisine forgé
Manche phenolkraff

Ref.	Largo Long Longueur	Color Colour Couleur
4000.100	100 mm	●●●●●
4000.150	150 mm	●●●●●
4000.200	200 mm	●●●●●
4000.250	250 mm	●●●●●
4000.300	300 mm	●●●●●

Cuchillo deshuesar
Mango phenoldraff

Boning knife
Phenoldraff handle

Couteau désosser
Manche phenolkraff

Ref.	Largo Long Longueur	Color Colour Couleur
4010.150	150 mm	●●●●●

Cuchillo jamonero
Mango phenolkraff

Ham knife
Phenolkraff handle

Couteau à désosser
Manche phenolkraff

Ref.	Largo Long Longueur	Color Colour Couleur
4020.300	300 mm	●●●●●

Trinchante cocinero
Mango phenolkraff

Carving knife
Phenolkraff handle

Couteau à découper
Manche phenolkraff

Ref.	Largo Long Longueur	Color Colour Couleur
4050.180	180 mm	●●●●●



Cuchillo Jamonero Mango Pom Alveolado

Ham indented knife handle pom

Couteau pour jambon alvéolé manche pom

Ref.	Largo Long Longueur	Color Colour Couleur
4120.250	250 mm	●
4120.300	300 mm	●



Cuchillo chef mango pom

Chef knife handle pom

Couteau de chef manche pom

Ref.	Largo Long Longueur	Color Colour Couleur
4100.250	250 mm	●



Cuchillo chef mango pom

Chef knife handle pom

Couteau de chef manche pom

Ref.	Largo Long Longueur	Color Colour Couleur
4100.200	200 mm	●



Cuchillo chef mango pom

Chef knife handle pom

Couteau de chef manche pom

Ref.	Largo Long Longueur	Color Colour Couleur
4100.150	150 mm	●



Cuchillo chef Santoku mango pom

Chef knife Santoku handle pom

Couteau de chef Santoku manche pom

Ref.	Largo Long Longueur	Color Colour Couleur
4105.180	180 mm	●



Cuchillo chef mango pom alveolado

Chef knife handle pom indented

Couteau de chef manche pom alvéolé

Ref.	Largo Long Longueur	Color Colour Couleur
4101.250	250 mm	●



Cuchillo chef para pan mango pom

Chef knife for bread handle pom

Couteau de chef pour pain manche pom

Ref.	Largo Long Longueur	Color Colour Couleur
4102.230	230 mm	●



Cuchillo Punta Aguda Mango Inyectado Anatomico y Antideslizante

Sharp Point Knife with Anatomical Injected Handle and Anti-Slip

Couteau à pointe fine avec manche injecté anatomique et antidérapant

Ref.	Largo Long Longueur	Color Colour Couleur
4200.150	150 mm	●●●●
4200.200	200 mm	●●●●
4200.250	250 mm	●●●●
4200.280	280 mm	●●●●



Cuchillo cocinero media luna

Half moon chef knife

Couteau de cuisine demi-lune

Ref.	Largo Long Longueur	Color Colour Couleur
4300.270	270 mm	●



Cuchillo de Golpe Mango Rallado Polipropileno

Hitting knife Polypropylene Grated Handle

Couteau à frapper Polypropylène Poignée Râpée

Ref.	Medidas Size Dimensions	Color Colour Couleur
0600.300	85 x 300 mm	●
0600.350	95 x 300 mm	●



Cuchillo cortante tallant
Mango inyectado

Cleaver knife
Plastic handle

Couperets
Manche en plastique

Ref.	Largo Long Longueur	Color Colour Couleur
0801.230	230 mm	● ● ● ● ● ●
0801.250	250 mm	● ● ● ● ● ●
0801.290	290 mm	● ● ● ● ● ●



Cuchillo cortante tallant
Cuchillo carnicero M/polietileno

Cleaver knife
Polyethylene handle

Couperets
Manche polyéthylène

Ref.	Largo Long Longueur	Peso Weight Poids	Color Colour Couleur
0820.240	240 mm	1000 gr	●
0820.260	260 mm	1200 gr	●



Cortante partir
Mango polietileno

Cleaver knife
Polyethylene handle

Couperet
Manche polyéthylène

Ref.	Largo Long Longueur	Color Colour Couleur
0840.320	320 mm	●



Cuchillo cortante tallant
Cuchillo carnicero M/inox

Cleaver knife
Stainless steel handle

Couperets
Manche inox

Ref.	Largo Long Longueur	Peso Weight Poids
0850.220	220 mm	1250 gr
0850.250	250 mm	1500 gr



Cuchillo filetero
Mango inyectado

Fillet knife
Plastic handle

Couteau à fileter
Manche en plastique

Ref.	Largo Long Longueur	Color Colour Couleur
0901.290	290 mm	●●●●●
0901.310	310 mm	●●●●●



Cuchillo chuletero
Mango inyectado

Chopping knife
Plastic handle

Couteau à côtelettes
Manche en plastique

Ref.	Largo Long Longueur	Color Colour Couleur
0905.290	290 mm	●●●●●
0905.310	310 mm	●●●●●

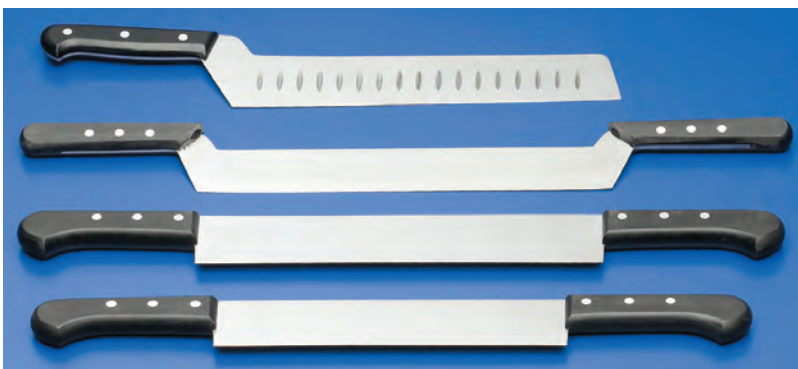

Cuchillo queso
1 mango acodado con alveolos. Mango Phenolkruff

Cheese knife
Phenolkruff handle

Couteau à fromage
Manche Phenolkruff

Ref.	Largo Long Longueur	Color Colour Couleur
1000.305	305 mm	●

Cuchillo queso
2 mangos acodado. Mango polietileno

Cheese knife
2 polyethylene handles

Couteau à fromage
2 manches en polyéthylène

Ref.	Largo Long Longueur	Color Colour Couleur
1001.320	320 mm	●

Cuchillo queso
2 mangos polietileno

Cheese knife
2 polyethylene handle

Couteau à fromage
2 manches en poléthylène

Ref.	Largo Long Longueur	Color Colour Couleur
1001.260	260 mm	●
1001.290	290 mm	●



Cuchillo queso curvado

Cheese curved knife

Fromage courbé couteau

Ref.	Largo Long Longueur	Color Colour Couleur
1000.450	45 cm	●



Cuchillo queso
Sierra mango phenolkruff

Cheese knife
Saw phenolkruff handle

Couteau à fromage
Scie manche en phenolkruff

Ref.	Largo Long Longueur	Color Colour Couleur
2002.250	250 mm	●
2002.310	310 mm	●



**Cuchillo charcutero salmón
Alveolado estrecho, mango polietileno**

Salmon charcuterie knife
Narrow indented, polythylene handle

*Couteau à Saumon
Alvólé étroite, manche polyéthylène*

Ref.	Largo Long Longueur	Color Colour Couleur
0560.250	250 mm	●
0560.310	310 mm	●



**Cuchillo charcutero-pastelero
Mango polietileno**

Carving-pastry knife
polyethylene handle

*Couteau de charcutier-pâtisser
Manche polyéthylène*

Ref.	Largo Long Longueur	Color Colour Couleur
0575.250	250 mm	●
0575.300	300 mm	●
0575.360	360 mm	●



**Aplasta filetes
Acero inox.**

Steak pounder
Stainless steel.

*Pelle pour aplatir les filets
Acier inox.*

Ref.	Peso Weight Poids
1705.150	1,5 kg



Gubia de bola m/polietileno blanco

Ball gouge m / polyethylene white ball

*Gouge à bille m / bille blanche en
polyéthylène*

Ref.	Largo Long Longueur	Color Colour Couleur
2401.260	260 mm	○



Aplasta filetes inox

Steak pounder

Pelle pour aplatir les filets

Ref.	Medidas Size Dimensions
1701.135	23 x 11 cm



Gubia recta

Gouge

Gouge

Ref.	Largo Long Longueur
2401.230	230 mm



Escamador pescado profesional

Professional fish scaller

Écailleur à poisson professionnel

Ref.	Largo Long Longueur
2526.000	25 cm



**Cuchillo puntilla
Mango Penolkraff**

Pointed knife

Couteau pointu

Ref.	Largo Long Longueur
0010.100	100 mm



**Cuchillo serie clásica puntilla
curva mango pom**

Classic series knife curved sprig
handle pom

*Série Classic couteau courbe
branche manche pom*

Ref.	Largo Long Longueur	Color Colour Couleur
0015.065	65 mm	●



Afilador manual sobremesa

Table manual knife sharpener

Aigiseur manuel de table

Ref.

F-40



Juego varillas diamante para ref. F-35

Set of rods for ref. F-35

Lot de tiges pour réf. F-35

Ref.

F-36



Afilador manual diamante

Manual diamond knife sharpener

Aigiseur manuel diamant

Ref.

F-35

CHAIRAS PROFESIONAL | PROFESSIONAL SHARPENERS | FUSILS PROFESSIONNELS



Chairas profesional redonda

Professional sharpeners round

Fusils professionnels, rond

Ref.	Largo Long Longueur
3000.200	20 cm
3000.250	25 cm
3000.300	30 cm

Profesional oval 30

Professional Oval

Profesional Rond

Ref.	Largo Long Longueur
3050.300	30 cm



Profesional redonda cruzeta inox 30 cm

Round 30 cm

Rond 30 cm

Ref.	Largo Long Longueur
3100.300	30 cm

Profesional oval cruzeta inox

Oval

Ovale

Ref.	Largo Long Longueur
3150.300	30 cm



Professional redonda

Round

Rond

Ref.	Largo Long Longueur	Color Couleur Couleur
3200.300-N	30 cm	●
3200.300-AZ	30 cm	●
3200.300-A	30 cm	●
3200.300-R	30 cm	●
3200.300-V	30 cm	●



Oval profesional

Oval

Ovale

Ref.	Largo Long Longueur	Color Couleur Couleur
3250.300-N	30 cm	●
3250.300-AZ	30 cm	●
3250.300-A	30 cm	●
3250.300-R	30 cm	●
3250.300-V	30 cm	●



Professional oval acero inoxidable

Oval stainless steel

Ovale acier inox

Ref.	Largo Long Longueur	Color Couleur Couleur
3400.300	30 cm	●

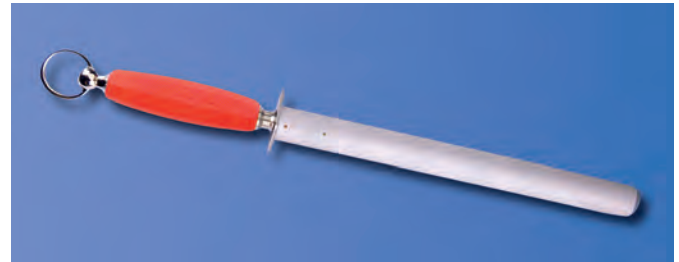

Lujo extra plana

Extra plane luxe

Luxe extra plat

Ref.	Largo Long Longueur	Color Couleur Couleur
3500.300	30 cm	●



Funda inyección para 4 cuchillos

Injection knife holder for 4 knives

Étui injection pour 4 couteaux

Ref.

F-10

Cinturón para funda inyección

Belt for réf. F-10

Ceinture pour réf. F-10

Ref.

F-11



**Pincha salchichas 6 pinchos
Mango plástico, acero inox**

Sausage poker 6-spikes
Plastic handle, stainless steel

*Pique saucisses 6 brochettes
Manche plastique, acier inox*

Ref.

F-12



**Pincha salchichas redondo 16
pinchos inox**

Sausage poker 16-spikes
stainless steel. Plastic handle.

*Pique saucisses 16 brochettes
inox. Manche plastique.*

Ref.

F-17



Aguja de mechar

Stuffing needle

Aiguille à farcir

Ref.

F-13

Largo
Long
Longueur

30 cm



Aguja para hilo

Thread needle

Aiguille pour fil

Ref.

F-14

Largo
Long
Longueur

30 cm

PIEDRAS AFILAR - AFILADOR MANUAL | WHETSTONES - MANUAL SHARPENER | PIERRES À AIGUISER - AIGUISEUR MANUEL



**Piedra de afilar natural. Grano negro.
Rombo**

Natural whetstone. Medium grain. Diamond shape

Pierre à aiguiser naturelle. Grain moyen. Losange.

Ref.

3900.700

Largo
Long
Longueur

23 cm

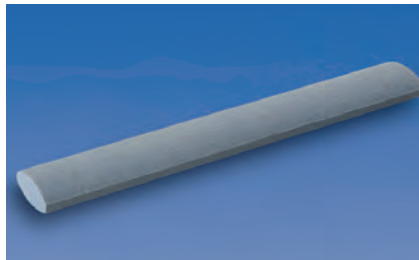

**Piedra de afilar corindón. Grano grueso.
Oval**

Natural whetstone. Rough grain. oval size

Pierre à aiguiser naturelle gros grain. Ovale

Ref.

3900.750

Largo
Long
Longueur

24 cm

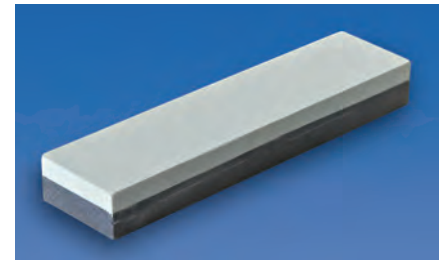

**Piedra de afilar silicada, 1 cara grano fino y
1 cara grano grueso**

Silicate whetstone 1 side rough grain, 1 side fine grain

Pierre à aiguiser silicate, 1 face gros grain, 1 face grain fin

Ref.

3900.995

Medidas
Size
Dimensions

20 x 5 x 2 cm



Hacha de cámara
Mango polietileno

Axe

Scie

Ref.

A-6



Hacha de corte, 1kg
Mango polietileno

Axe, 1kg

Scie, 1kg

Ref.

A-16

TIJERAS MANUALES | MANUAL SCISSORS | CISEAUX MANUEL



Tijera pollero

Poultry scissors

Ciseaux volaille

Ref.	Largo Long Longueur
TP-210	21 cm
TP-230	23 cm
TP-250	25 cm



Tijera cocina-pescado
Con Tornillo

Kitchen-fish scissors

Ciseaux cuisine-poisson

Ref.	Largo Long Longueur
TC-180	18 cm
TC-200	20 cm
TC-220	22 cm
TC-240	24 cm
TC-280	28 cm



Tijera forjada

Forged scissors

Ciseaux forgés

Ref.	Largo Long Longueur
TF-200	20 cm
TF-225	22,5 cm



Tijera trinchar

Kitchen scissors

Ciseaux à découper

Ref.	Largo Long Longueur
TT-265	26,5 cm



Espátula plancha

Spatula

Spatule

Ref.	Largo Long Longueur
A-21	9 cm



Espátula pastelero

Spatula

Spatule

Ref.	Largo Long Longueur
A-51	20 cm



Espátula pastelero

Spatula

Spatule

Ref.	Largo Long Longueur
A-52	25 cm



Paleta charcutería

Spatula

Spatule

Ref.	Medidas Size Dimensions
A-14	12 x 6 cm



Paleta acodada

Spatula

Spatule

Ref.	Medidas Size Dimensions
A-22	15 x 8 cm



Paleta besugo ancha

Spatula

Spatule

Ref.	Medidas Size Dimensions
A-53	16 x 19 cm



Paleta besugo larga

Spatula

Spatule

Ref.	Medidas Size Dimensions
A-54	25 x 8 cm

BACALADERA - TIJERAS MOSTRADOR | MANUAL FISH SHEARS - COUNTER SCISSORS | MORUTIEL MANUEL - CISEAUX COMPTOIR

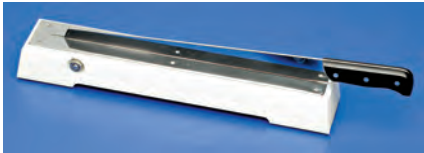

**Bacaladera manual
Base polietileno**

Manual fish shears
Polyethylene base

*Morutiel manuel
Base polyéthylène*

Ref.

A-25



**Tijera mostrador con soporte inox
Mango polietileno**

Counter scissors with stainless steel
Polyethylene handel

*Ciseaux comptoir avec support inox
Manche polyéthylène*

Ref.

TM-430

Largo
Long
Longueur

43 cm

TM-500

50 cm



Abre-ostras acero-inox con protector

Stainless steel oyster sucker

Couteau à huitres inox

Ref.

A-2



Rasqueta multiservicio

Multipurpose scarping

Raclette multiservice

Ref.

A-18

Medidas
Size
Dimensions

15 x 12 cm



Abre-ostras industrial

Industrial oyster sucker

Couteau à huitres industrial

Ref.

A-56

SIERRAS | SAWS | SCIÉS



**Sierra huesos
Inox, Mango negro**

Bones saw
Stainless steel, black handle

*Scie à os
Inox, anche noir*

Ref.

2460.400

Largo
Long
Longueur

40 cm

2460.450

45 cm

2460.500

50 cm

Hoja recambio sierra inox

Spare blade

Lame de rechange pour

Ref.

2476.420

Largo
Long
Longueur

40 cm

2476.450

45 cm

2476.500

50 cm

IMANES | MAGNETS | AIMANTS

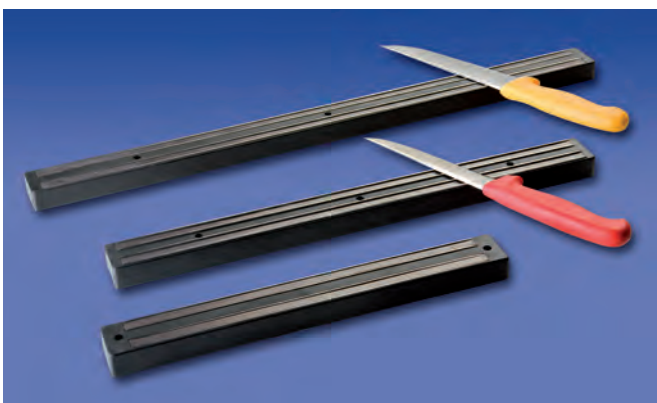

Imanes

Magnets

Aimants

Ref.

2500.330

Largo
Long
Longueur

33 cm

2500.450

45 cm

2500.600

60 cm



Guillotina queso blando
Base polietileno

Guillotine for slicing soft cheese
Polyethylene base

Guillotine pour découper le fromage à pâte
Base en polyéthylène

Ref.

F-20

Recambio guillotina ref. F-20
Pack 10 unidades

Spare lyre for ref. F-20
Pack 10 units

Fil pour réf. F-20
Pack 10 unités

Ref.

F-21

Unidades
Units
Unités

10

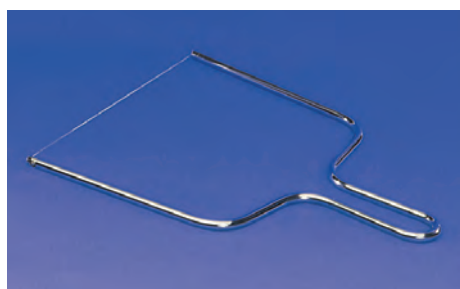

Lira queso blando de 21 cm

Lyre arch for slicing soft cheese

Arc lyre pour découper le fromage à pâte

Ref.

F-15

Recambio lira Ref. F-15
Pack 10 unidades

Spare lyre for ref. F-15
Pack 10 units

Fil pour réf. F-15
Pack 10 unités

Ref.

F-16

Unidades
Units
Unités

10



Rizador queso
Base madera 22 cm diametro

Cheese curling
Wood base 22 cm diameter

Fraiseur de fromage
Base de bois 22 cm diamètre

Ref.

F-22

ABRELATAS Y SACACORCHOS | CAN OPENERS - CORKSCREW | OUVRE-BOÎTES - TIRE-BOUCHON



Sacacorchos cromado pared

Chrome wall corkscrew

Tire-bouchon chromé mur

Ref.

A-65



Abrelatas industrial inox

Stainless steel industrial can opener

Ouvre-boîtes inox industriel

Ref.

A-70



Guantes 5 dedos inox banda plástico reversibles

Finger reversible stainless steel gloves plastic band

Gants 5 doigts inox bande plastique réversibles

Ref.	Color Colour Couleur	Tipo Type Type
A-1050-X	●	XXS
A-1051-X	●	XS
A-1052-X	○	S
A-1053-X	●	M
A-1054-X	●	L
A-1055-X	●	XL



Sujeción de plástico para guantes inox

Plastic strap for stainless steel gloves

Fixation en plastique pour gants inox

Ref.	Unidades Units Unités
A-1001	100



Guantes 5 dedos inox banda plástico reversibles CHAINEX

5-finger reversibles stainless steel gloves plastic band CHAINEX

Gants 5 doigts inox bande plastique réversibles CHAINEX

Ref.	Color Colour Couleur	Tipo Type Type
A-1050	●	XXS
A-1051	●	XS
A-1052	○	S
A-1053	●	M
A-1054	●	L
A-1055	●	XL

GUANTES ACERO-INOX CON MANGUITO | STAINLESS STEEL GLOVES WITH SLEEVE | GANTS ACIER INOX AVEC MANCHETTE

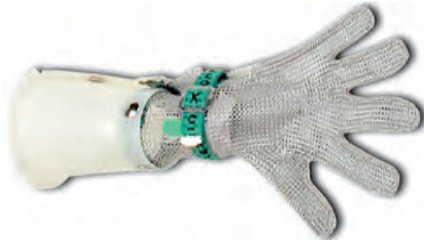

Guantes 5 dedos inox banda nylon con manguito policarbonato CHAINEX

5-finger stainless steel gloves with polycarbonate sleeve CHAINEX

Gants 5 doigts inox bande nylon avec manchette polycarbonate CHAINEX

Ref.	Color Colour Couleur	Tipo Type Type
A-1020	●	XXS
A-1021	●	XS
A-1022	○	S
A-1023	●	M
A-1024	●	L



Guantes 5 dedos inox banda nylon con manguito inox 16.5 cm reversible CHAINEX

5-finger stainless steel gloves nylon band with reversible 16.5 cm stainless steel sleeve CHAINEX

Gants 5 doigts inox bande nylon avec manchette inox 16.5 cm réversible CHAINEX

Ref.	Color Colour Couleur	Tipo Type Type
A-1110	●	XXS
A-1111	●	XS
A-1112	○	S
A-1113	●	M
A-1114	●	L
A-1115	●	XL



Manguito plástico de 14 cm

Plastic sleeve 14 cm

Manchette plastique 14 cm

Ref.	Largo Long Longueur
A-1000	14 cm



Guantes protección textil, 2 un. Talla pequeña. Banda de color blanco.

Textile cut-protection gloves. Size S. Band of white color.

Gants anti coupures textile. Taille S. Bande de couleur blanche.

Ref.	Tipo Type Type
A-2001	S 7



Guantes protección textil, 2 un. Talla mediana. Banda de color rojo.

Textile cut-protection gloves. Size M. Band of red color.

Gants anti coupures textile. Taille M. Bande de couleur rouge.

Ref.	Tipo Type Type
A-2002	M 8



Guantes protección textil, 2 un. Talla grande. Banda de color azul

Textile cut-protection gloves. Size L. Band of blue color

Gants anti coupures textile. Taille L. Bande de couleur bleue

Ref.	Tipo Type Type
A-2003	L 9



Guantes protección textil, 2 un. Talla muy grande. Banda de color naranja

Textile cut-protection gloves. Size XL. Orange band

Gants anti coupures textile. Taille XL. Bande orange

Ref.	Tipo Type Type
A-2004	XL 10



Manopla silicona 300°

Silicon oven mitts 300°

Gant antichaleur silicone 300°

Ref.

A-3000



Manopla silicona 300° extra larga

Silicon oven mitts 300°

Gant antichaleur silicone 300° XL

Ref.

A-3005





Delantal malla acero CHAINEX
Medidas 75 x 55

Stainless steel mesh apron CHAINEX
 Size 75 x 55

Tablier maille acier inox CHAINEX
Medidas 75 x 55

Ref.	Medidas Size Dimensions
A-9-76M	75 x 55 cm



Delantal PVC

PVC apron

Tablier PVC

Ref.	Medidas Size Dimensions	Color Colour Couleur
A-11-120-AZ	70 x 120	●
A-11-90	70 x 90	○
A-11-90-AZ	70 x 90	●
A-11-90-N	70 x 90	●
A-11-90-R	70 x 90	●



Delantal TPU ligero

TPU apron LIGHT

Tablier TPU LÉGER

Ref.	Medidas Size Dimensions	Color Colour Couleur
A-11-110	87 x 115	○

Delantal textil

Textile apron

Tablier textile

Ref.	Medidas Size Dimensions
A-17-B	75 x 90 cm
A-17-P	75 x 90 cm
A-17-BU	75 x 90 cm
A-17-F	75 x 90 cm
A-17-N	75 x 90 cm

Delantal textil rayado

Textil apron striped

Tablier textile rayé

Ref.	Medidas Size Dimensions
A-17-NV	75 x 90 cm
A-17-NBU	75 x 90 cm
A-17-BR	75 x 90 cm
A-17-BAZ	75 x 90 cm
A-17-BV	75 x 90 cm



**Guantes nitrilo
Paquete 100 uds.**

Nitrile gloves
100 units per box

Gants nitrile
Boîte 100 uts.

Ref.	Tipo Type Type
A-38-P	S
A-38-M	M
A-38-G	L



Guantes plástico "un solo uso", paquete 100 und.

Disposable plastic gloves, 100 uts box

Gants de plastique d'un seul usage, boîte 100 uts.

Ref.	Unidades Units Unités
A-12	100



Gorro circular blanco.
Paquete 100 uds

Round cap
100 uts box

Bonnet circulaire
Boîte 100 uts

Ref.

A-83 polipropileno

A-83-X polietileno

Cubremanga polietileno
Paquete 100 und

Polyethylene sleeve cover
100 uts box

Polyéthylène couvre manches
Boîte 100 uts

Ref.

A-86

Bata polietileno visitante
Paquete 10 und

Polyethylene visitor's coat
10 uts box

Blouse polyéthylène visiteur
Boîte 10 uts

Ref.

A-87 (CONSULTAR)

Bata blanca de polipropileno
Paquete 10 und

White polypropylene coat
10 uts box

Blouse blanche polypropylene
Boîte 10 uts

Ref.

A-82 (CONSULTAR)

Cubrezapatos azul
Paquete 200 und

Shoes cover
200 uts box

Couvre chaussures
Boîte 200 uts

Ref.

A-84



Delantal polietileno 69 x 122
Paquete 80 und

Polyethylene apron 69 x 122
80 uts box

Tablier de polyéthylène 69 x 122
Boîte 80 uts

Ref.

A-85

Mascarilla polipropileno tres capas
Paquete 50 und

Mask in polypropylene three layers
50 uts box

Masque en polypropylène trois couches
Boîte 10 uts

Ref.

A-89 (CONSULTAR)



1

0

**Estanterias, Plataformas, Tarima antifatiga,
Palets, Losetas, Bancos de vestuario, Taquillas.**

Shelves, Platforms, Anti-fatigue mat, Pallets, Tiles,
Locker room bench, Lockers.

*Étagères, Plate-formes, Sol anti-fatigue, Palettes,
Carreaux, Banc vestiare, Casiers.*

183 - 196

HIGIÉNICAS

- Superficie lisa y no porosa.
- Fabricadas con resina de alta calidad.
- Evitan la condensación.
- No se oxidan.
- Cantos redondeados, para evitar accidentes.
- Colores: gris y beige.

RESISTENTES

- Resistencia a la carga 400 kg/m².
- Temperatura desde -40°C a 80°C.
- Inalterables a ácidos, aceites, grasa y humedades.
- No se manchan con el uso de detergentes.

VERSÁTILES

- Se amplian fácilmente con nuevos elementos.
- Se amoldan sin dificultad a diferentes alturas.
- Módulos especialmente diseñados para un máximo aprovechamiento de las esquinas.
- Pies regulables (opcionales), para suelos irregulares o inclinados.
- Ruedas (opcionales).

HYGIÉNIQUES

- Surface lisse et non poreuse.
- Fabriquées avec de la résine de grande qualité.
- Évitent la condensation.
- Ne se rouillent pas.
- Bords arrondis pour éviter les blessures.
- Couleurs: Gris et beige.

RÉSISTANTS

- Résistance à la charge 400 kg/m².
- Températures de -40°C à 80°C.
- Résistantes aux acides, huiles, graisses et à l'humidité.
- Ne se tachent pas avec l'utilisation de détergents.

VERSATILES

- Peuvent être facilement étendu avec de nouveaux éléments.
- Ils s'adaptent facilement à différentes hauteurs.
- Modules spécifiquement dessinées pour une utilisation optimale des coins.
- Pieds réglables (optionnels), pour terrains irréguliers ou inclinés.
- Roues (optionnelles).

MODULABLES

- Ils s'adaptent à toute organisation de l'espace.
- Ils sont construits sur mesure.

ADAPTABLES

- Modules dessinés pour convenir à tous les besoins.
- Ils se montent très facilement, sans avoir besoin d'outils grâce.
- Elles peuvent être déplacée aisément.

HYGIENIC

- Smooth non-porous surface.
- Manufactured with premium quality resin.
- They prevent condensation.
- Non rust.
- Rounded edges, to prevent accidents.
- Colours: Grey & beige.

HARDWEARING

- Withstand load of 400 kg/m².
- Temperatures from -40°C to 80°C.
- Unchanging to acids, oils, grease and moisture.
- Detergents doesn't stain it.

VERSATILE

- Easily extended with new elements.
- Adaptable to different heights.
- Modules specifically designed for optimal use of corners.
- Adjustable feet (optional), for uneven or sloping floor.
- Wheels (optional).

MODULAR

- They can fit at any pace allocation.
- They can be manufacture with any measure previous order.

ADAPTABLE

- Modules designed to suit any need.
- Very easy assembly without using metallic elements.
- Its lightness makes it very easy to move.

MODULARES

- Se acoplan a cualquier distribución de espacio.
- Sobre pedido se construyen en cualquier medida.

ADAPTABLES

- Módulos diseñados para adaptarse a cualquier necesidad.
- Se montan con mucha facilidad sin precisar elementos metálicos.
- Su ligereza permite desplazarlas fácilmente.



Estanterías de plástico 4 estantes cantos rectos

Plastic shelves 4 shelves straight edges

Étagères en plastique 4 étagères bords droits

Ref.	Medidas Size Dimensions	Color Colour Couleur
K-104	100 x 40 x 150 cm	OO●
K-105	100 x 50 x 150 cm	OO●
K-106	100 x 60 x 150 cm	OO●
K-124	120 x 40 x 150 cm	OO●
K-125	120 x 50 x 150 cm	OO●
K-126	120 x 60 x 150 cm	OO●
K-154	150 x 40 x 150 cm	OO●
K-155	150 x 50 x 150 cm	OO●
K-156	150 x 60 x 150 cm	OO●
K-204	200 x 40 x 150 cm	OO●
K-205	200 x 50 x 150 cm	OO●
K-206	200 x 60 x 150 cm	OO●

Estantería de plástico 5 estantes cantos rectos

Plastic shelves 5 shelves

Étagères plastique 5 étages

Ref.	Medidas Size Dimensions	Color Colour Couleur
K-104-5	100 x 40 x 175 cm	OO●
K-105-5	100 x 50 x 175 cm	OO●
K-106-5	100 x 60 x 175 cm	OO●
K-124-5	120 x 40 x 175 cm	OO●
K-125-5	120 x 50 x 175 cm	OO●
K-126-5	120 x 60 x 175 cm	OO●
K-154-5	150 x 40 x 175 cm	OO●
K-155-5	150 x 50 x 175 cm	OO●
K-156-6	150 x 60 x 175 cm	OO●
K-204-5	200 x 40 x 150 cm	OO●
K-205-5	200 x 50 x 175 cm	OO●
K-206-5	200 x 60 x 175 cm	OO●



Rueda poliamida sin stop + refuerzo

Polyamide wheel without stop + reinforcement

Roue polyamide sans stop + reinforcement

Ref.

K-15-PS



Rueda cincada sin stop + refuerzo

Covered wheel without stop + reinforcement

Roue couverte sans stop + renfort

Ref.

K-15-S



Pie regulable

Adjustable foot

Pied réglable

Ref.

K-10



Rueda cincada stop + refuerzo

Covered wheel

Roue couverte

Ref.

K-15



Rueda poliamida stop + refuerzo

Polyamide wheel

Roue polyamide

Ref.

K-15-P



Superficie lisa opcional polietileno 3 m/m

Optional 3 m/m polyethylene surface
Optionnel polyéthylène lisse 3 m/m



Desmontadas para transporte - Fácil manejo

Dismantled to be transported - Easy to use
Démonté pour le transport - Fonctionnement simple

ESTANTERÍAS RESISTENTES, HIGIÉNICAS, PLEGABLES Y VERSÁTILES

- Resistencia a la carga 250 kg/m².
- Temperatura desde -40°C a 80°C.
- Inalterable a la humedad, ácidos, aceites y grasas.
- No se mancha con el uso de detergentes.

HIGIÉNICAS

- Superficie no porosa.
- Fabricadas con resinas plásticas de alta calidad.
- Evitan la condensación.
- No se oxidan.
- Cantos romos para evitar accidentes.
- Baldas extraíbles para su lavado en lavavajillas.

VERSÁTILES

- Ampliables con nuevos elementos (modulares).
- Fácilmente amoldables a nuevas alturas.
- Módulos especialmente diseñados para un mejor aprovechamiento de las esquinas.
- Accesorios para diferentes utilidades.
- Plegables para el mejor aprovechamiento de espacios.
- Baldas rejadas o llenas.

HARDWEARING , HYGIENIC, FOLDABLE AND VERSATILE SHELVES

- Withstand load of 250 kg/m².
- Temperatures from -40°C a 80°C.
- Not altered by humidity, acids, oils, grease.
- Are not stained by detergents.

HYGIENIC

- Non-porous surface.
- Made with high quality plastic resins.
- Avoid condensation.
- Will not rust.
- Blunt edges to avoid accidents.
- Shelves removable for washing in dishwasher.

VERSATILE

- Expandable with new elements (modular).
- Easily adaptable to new heights.
- Modules specifically designed for optimal use of corners.
- Accessories for different utilities.
- Foldables for better use of spaces.
- Shelves grilled or plain.

ÉTAGÈRES RÉSIDANTES, HYGIÉNIQUES, PLIANTES ET VERSATILES

- Résistance à la charge 250 kg/m².
- Température de -40°C a 80°C.
- Inaltérables à l'humidité, aux acides, à l'huile et aux graisses.
- Ne se tachent pas avec l'utilisation de détergents.

HYGIÉNIQUE

- Surface non poreuse.
- Fabriquées avec de la résine de grande qualité.
- Évitent la condensation.
- Ne se rouillent pas.
- Bords arrondis pour éviter les accidents.
- Étagères amovibles pour le lavage en lave-vaisselle.

POLYVALENT

- Extensibles avec de nouveaux éléments (modulaires).
- Facilement adaptables à de nouvelles hauteurs.
- Modules spécialement dessinés pour une utilisation optimale des coins.
- Accessoires pour les différentes utilisations.
- Pliantes pour une meilleure utilisation de l'espace.
- Étagères en grillé ou lisses.

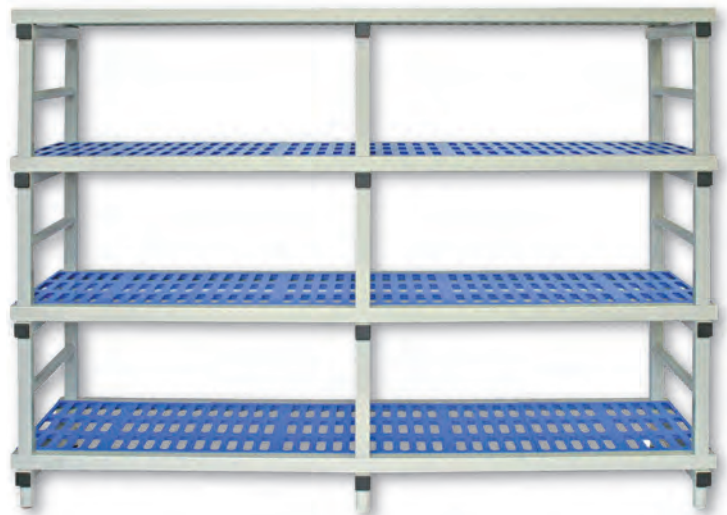

Baldas en tres formatos distintos que permiten montar estanterías de distintas profundidades / Three different formats shelves that allow assembling with different depth / Étagères dans trois formats différents qui permettent le montage de différentes profondeurs

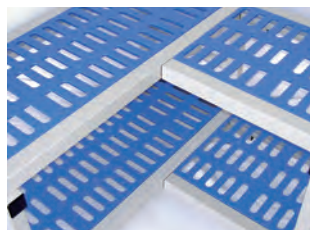

Encaje en "L" / "L" fitting / Luce "L"



Rueda / Wheel / Roues



Pata regulable / Adjustable foot / Pied réglable



Sistema de encaje /
Fitting system /
Système de verrouillage



KML: Estante liso / Plain shelve /
Étagère lisse



KM: Estante rejilla

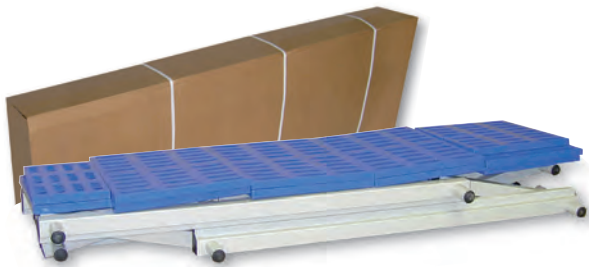

El sistema de plegado permite optimizar el volumen de empaquetado y transporte /
Folding system makes improve packaging and transportation /
Le système de pliage permet d'optimiser le volume des emballages et des transports



Baldas extraíbles para facilitar su lavado, pueden lavarse en el lavavajillas /
Removable shelves to make them easy to wash, they can be cleaned in the dishwasher /
Étagères amovibles pour faciliter le ménage, peut être lavée dans le lave-vaisselle

Estantería de plástico plegable 5 estantes

Foldable plastic shelf 5 shelves

Étagère plastique pliante 5 étagères

Ref.	Medidas Size Dimensions	Color Colour Couleur
KM-104-5	100 x 40 x 175 cm	○○●
KM-105-5	100 x 50 x 175 cm	○○●
KM-106-5	100 x 60 x 175 cm	○○●
KM-124-S	120 x 40 x 175 cm	○○●
KM-125-5	120 x 50 x 175 cm	○○●
KM-126-5	120 x 60 x 175 cm	○○●
KM-154-5	150 x 40 x 175 cm	○○●
KM-155-5	150 x 50 x 175 cm	○○●
KM-156-5	150 x 60 x 175 cm	○○●
KM-204-5	200 x 40 x 175 cm	○○●
KM-205-5	200 x 50 x 175 cm	○○●
KM-206-5	200 x 60 x 175 cm	○○●

Estantería de plástico plegable 4 estantes

Foldable plastic shelf 4 shelves

Étagère plastique pliante 4 étagères

Ref.	Medidas Size Dimensions	Color Colour Couleur
KM-104	100 x 40 x 150 cm	○○●
KM-105	100 x 50 x 150 cm	○○●
KM-106	100 x 60 x 150 cm	○○●
KM-124	120 x 40 x 150 cm	○○●
KM-125	120 x 50 x 150 cm	○○●
KM-126	120 x 60 x 150 cm	○○●
KM-154	150 x 40 x 150 cm	○○●
KM-155	150 x 50 x 150 cm	○○●
KM-156	150 x 60 x 150 cm	○○●
KM-204	200 x 40 x 150 cm	○○●
KM-205	200 x 50 x 150 cm	○○●
KM-206	200 x 60 x 150 cm	○○●

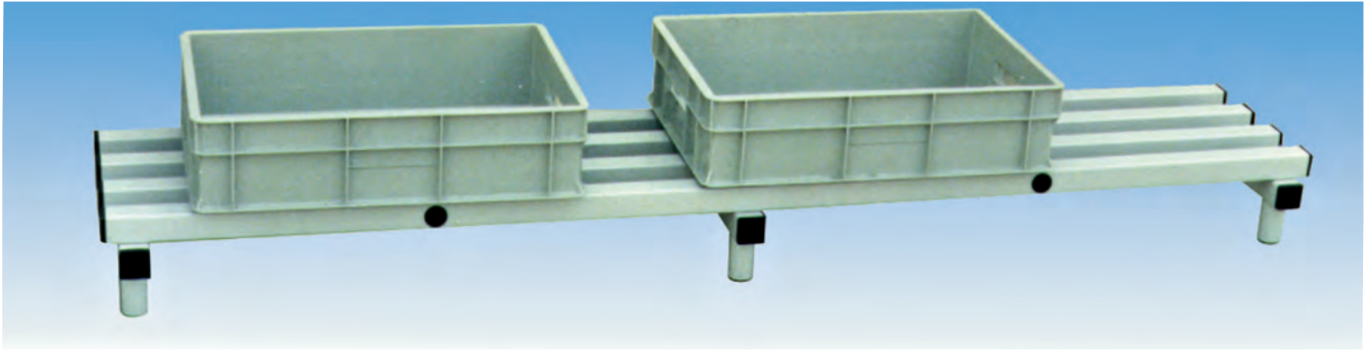

Plataforma para suelo camara

Platform for cold storage room floor

Plate-forme pour sol chamber

Ref.	Medidas Size Dimensions	Color Colour Couleur
KP-104	100 x 40 x 16,5 cm	OO●
KP-105	100 x 50 x 16,5 cm	OO●
KP-106	100 x 60 x 16,5 cm	OO●
KP-124	120 x 40 x 16,5 cm	OO●
KP-125	120 x 50 x 16,5 cm	OO●
KP-126	120 x 60 x 16,5 cm	OO●

Ref.	Medidas Size Dimensions	Color Colour Couleur
KP-154	150 x 40 x 16,5 cm	OO●
KP-155	150 x 50 x 16,5 cm	OO●
KP-156	150 x 60 x 16,5 cm	OO●
KP-204	200 x 40 x 16,5 cm	OO●
KP-205	200 x 50 x 16,5 cm	OO●
KP-206	200 x 60 x 16,5 cm	OO●

TARIMA ANTIFATIGA | ANTI-FATIGUE MAT | SOL ANTI-FATIGUE

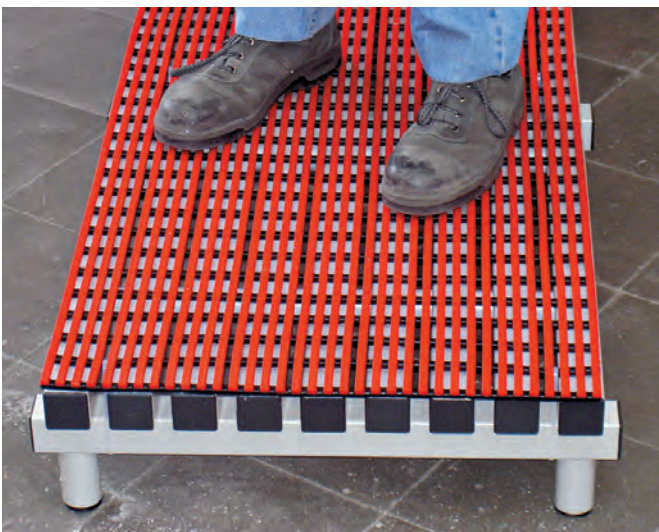

Tarima antifatiga

Ergonomía: Alfombra antifatiga, mejoran el rendimiento del trabajador, son termoaislantes, protegen contra el frío.

Seguridad: Evitan deslizamientos en el puesto de trabajo y posibles descargas eléctricas, calidad antideslizante de clase R10/V10.

Medio ambiente: Fabricadas en material reciclado.

Color base gris, suelo azul.

Anti-fatigue mat
Ergonomics: Anti-fatigue carpeted mat, improve work performance, they are heat insulating, protected against the cold.

Safety: Prevent slipping over the work place and possible electric charges, class R10/V10 anti-slip quality.

Environment: Made of recycled material.

Grey base color, blue floor.

Sol anti-fatigue

Ergonomie: Tapis anti fatigue, améliore le rendement du travailleur, il est thermo isolant et protège du froid.

Sécurité: Il évite les glissades sur le poste de travail et d'éventuelles décharges électriques, qualité anti glissade de type R10/V10.

Environnement: Fait de matériaux recyclés.

Couleur de base gris, sol bleu.

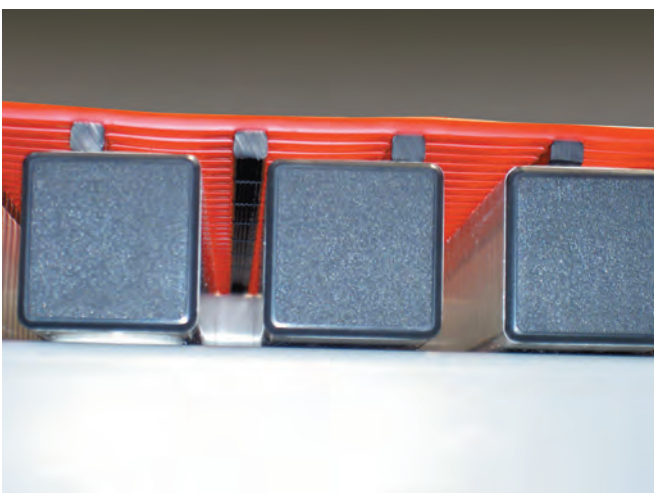

Ref.	Medidas Size Dimensions
KTA-105	100 x 50 x 18 cm
KTA-106	100 x 60 x 18 cm
KTA-107	100 x 70 x 18 cm
KTA-108	100 x 80 x 18 cm



Palet liso reciclado negro
Carga dinámica hasta 850 kg. Carga estática hasta 3.400 kg. Superficie apoyo 9 patas

Black smooth perforated pallet
 Dynamic load up to 850 kg. Static load up to 3.400 kg. 9-leg support surface

Palette lisse recyclée noire
Charge dynamique jusqu'à 850 kg. Charge statique jusqu'à 3.400 kg. Surface soutien 9 pattes

Palet liso alimentario blanco
Carga dinámica hasta 850 kg. Carga estática hasta 3.400 kg. superficie apoyo 9 patas

Smooth white food-product pallet
 Dynamic load up to 850 kg. Static load up to 3.400 kg. 9-leg support surface

Palette unie alimentaire blanche
Charge dynamique jusqu'à 850 kg. Charge static jusqu'à 3.400 kg. Surface soutien 9 pattes

Ref.	Medidas Size Dimensions	Peso Weight Poids
KP-300	120 x 80 x 14,5 cm	7,5 kg

Ref.	Medidas Size Dimensions	Peso Weight Poids
KP-350	120 x 80 x 14,5 cm	7,5 kg



Palet plástico reciclado negro
Carga dinámica hasta 1.000 kg. Carga estática hasta 4.000 kg

Plastic black recycled pallet
 Dynamic load up to 1.000 kg. Static load up to 4.000 kg.

Palette plastique recyclé noire
Charge dynamique jusqu'à 1.000 kg. Charge statique jusqu'à 4.000 kg.



Palet perforado reciclado negro
Carga dinámica hasta 850 kg. Carga estática hasta 3.400 kg. Superficie apoyo 9 patas

Black recycled perforated pallet
 Dynamic load up to 850 kg. Static load up to 3.400 kg. 9-leg support surface

Palette perforée recyclée noire
Charge dynamique jusqu'à 850 kg. Charge statique jusqu'à 3.400 kg. Surface soutien 9 pattes

Ref.	Medidas Size Dimensions	Peso Weight Poids
KP-250	120 x 80 x 14,5 cm	6,5 kg

Ref.	Medidas Size Dimensions	Peso Weight Poids
KP-400	120 x 80 x 16 cm	21 kg



Palet plástico gris alimentario
Carga dinámica hasta 1.000 kg. Carga estática hasta 4.000 kg.

Plastic grey pallet food
 Dynamic load up to 1.000 kg. Static load up to 4.000 kg

Palette plastique gris nourriture
Charge dynamique jusqu'à 1.000 kg. Charge statique jusqu'à 4.000 kg.

Ref.	Medidas Size Dimensions	Peso Weight Poids
KP-500	120 x 80 x 16 cm	18



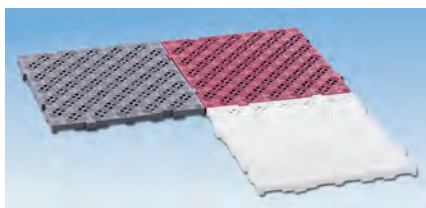

Loseta suelo

Floor tile

Carreaux sol

Ref.	Medidas Size Dimensions	Color Colour Couleur
KL-25	50 x 50 x 2,5 cm	●○●

Otros colores consultar.
Consult other colors.
Consultez d'autres couleurs.

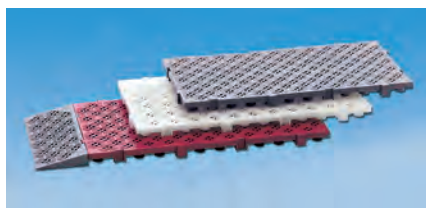

Loseta suelo

Floor tile

Carreaux sol

Ref.	Medidas Size Dimensions	Color Colour Couleur
KL-100	100 x 50 x 5 cm	●○●

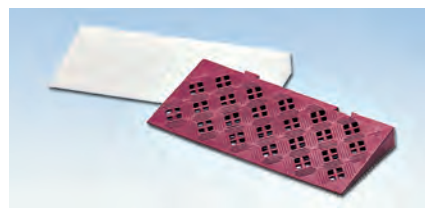

Rampa para ref. KL-100 y KL-55

Floor rampe for ref. KL-100 and KL-55

Rampe sol for réf. KL-100 et KL-55

Ref.	Medidas Size Dimensions	Color Colour Couleur
KL-50	50 x 20 cm	●○●

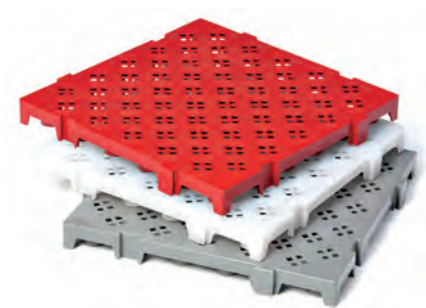

Loseta suelo

Floor tile

Carreaux sol

Ref.	Medidas Size Dimensions	Color Colour Couleur
KL-55	50 x 50 x 5 cm	●○●

BANCOS DE VESTUARIO CANTOS RECTOS | LOCKER ROOM BENCH | BANC VESTIAIRE



kbv - Banco vestuario

kbv - Locker room bench

kbv - Banc vestiaire

Ref.	Medidas Size Dimensions	Color Colour Couleur
KBV-100	100 x 35 x 48,5 cm	○○●
KBV-150	150 x 35 x 48,5 cm	○○●
KBV-200	200 x 35 x 48,5 cm	○○●



**SON VERSÁTILES RESISTENTES
Y MUY COMPETITIVAS /**
VERSATILES, RESISTANTS
AND VERY COMPETITIVES /
VERSATILES, RESISTANTS
AND TRÈS COMPETITIVES

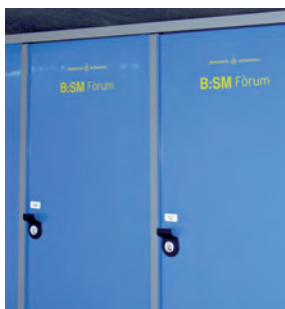

Personalización /
Customization /
Personnalisation



Patas regulables /
Adjustable foot /
Pied réglable



Cerradura de moneda /
Coin lock /
Pièce de verrouillage

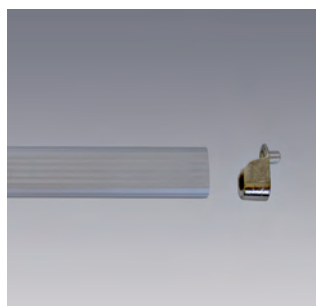

1/2 estante y barra de colgar /
Shelve and holding rail /
Étagère et garde-robe



Cerradura estándar /
Standard lock /
Verrouillage standard

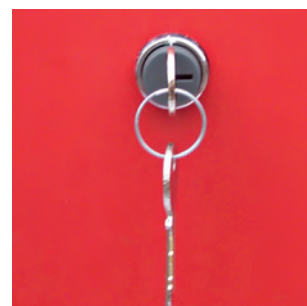

Cerradura estándar /
Standard lock /
Verrouillage standard



Cierre por resbalón /
Easy lock /
Fermature par glissement

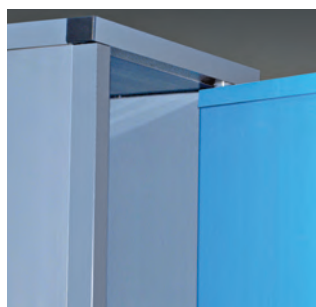

Puerta pivotante /
Hinging door /
Porte pivotante



1/2 estante y barra de colgar /
Shelve and holding rail /
Étagère et garde-robe



Pulsera numerada /
Numbered bracelet /
Bracelet numéree

GAMA 300

Cerradura de tipo pitones con 3.120 nº de combinaciones.
Cierre central y posibilidad de amaestramiento.
Color carcás en gris.
Color de la puerta en azul, rojo, beige o gris claro.

Material resinas de polivinilo.
Patás regulables de 13 a 18 cms.
Clasificación M1 según norma UNE 23727.

GAMA 300





Cerradura de tipo pitones con 3.120 nº de combinaciones.
 Cierre central y posibilidad de amaestramiento.
 Color carcás en gris.
 Color de la puerta en azul, rojo, beige o gris claro.

Material resinas de polivinilo.
 Patás regulables de 13 a 18 cms.
 Clasificación M1 según norma UNE 23727.

GAMA 300

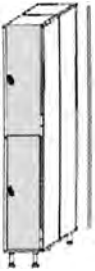
Cerradura de tipo pitones con 3.120 nº de combinaciones.
 Cierre central y posibilidad de amaestramiento.
 Color carcás en gris.
 Color de la puerta en azul, rojo, beige o gris claro.

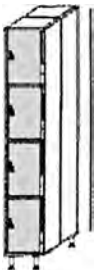
Material resinas de polivinilo.
 Patás regulables de 13 a 18 cms.
 Clasificación M1 según norma UNE 23727.

	Módulo Module Module	Puerta Door Porte	Nº de Puertas Nº of doors Nº de portes	Medidas exterior total Total external size Dimension extérieure totale	Hueco útil por taquilla Useful space Creux utile	Ref.	Accesorios incluidos Accessories included Accessoires inclus
	M1	P1	1	29,4 x 53,7 x 191,5 cm	24,6 x 48,9 x 174 cm	K3M1P1	
	M2	P1	2	55,7 x 53,7 x 191,5 cm	24,6 x 48,9 x 174 cm	K3M2P1	
	M3	P1	3	82,2 x 53,7 x 191,5 cm	24,6 x 48,9 x 174 cm	K3M3P1	1/2 Estante y barra Shelve and holding rail
	M4	P1	4	108,7 x 53,7 x 191,5 cm	24,6 x 48,9 x 174 cm	K3M4P1	Étagere et garderobe
	M5	P1	5	135,2 x 53,7 x 191,5 cm	24,6 x 48,9 x 174 cm	K3M5P1	
	M6	P1	6	161,7 x 53,7 x 191,5 cm	24,6 x 48,9 x 174 cm	K3M6P1	
	M1	P2	2	29,4 x 53,7 x 191,5 cm	24,6 x 48,9 x 85,9 cm	K3M1P2	
	M2	P2	4	55,7 x 53,7 x 191,5 cm	24,6 x 48,9 x 85,9 cm	K3M2P2	
	M3	P2	6	82,2 x 53,7 x 191,5 cm	24,6 x 48,9 x 85,9 cm	K3M3P2	Barra de colgar Holding rail
	M4	P2	8	108,7 x 53,7 x 191,5 cm	24,6 x 48,9 x 85,9 cm	K3M4P2	Garde-robe barre
	M5	P2	10	135,2 x 53,7 x 191,5 cm	24,6 x 48,9 x 85,9 cm	K3M5P2	
	M6	P2	12	161,7 x 53,7 x 191,5 cm	24,6 x 48,9 x 85,9 cm	K3M6P2	
	M1	P3	3	29,4 x 53,7 x 191,5 cm	24,6 x 48,9 x 56,5 cm	K3M1P3	
	M2	P3	6	55,7 x 53,7 x 191,5 cm	24,6 x 48,9 x 56,5 cm	K3M2P3	
	M3	P3	9	82,2 x 53,7 x 191,5 cm	24,6 x 48,9 x 56,5 cm	K3M3P3	
	M4	P3	12	108,7 x 53,7 x 191,5 cm	24,6 x 48,9 x 56,5 cm	K3M4P3	
	M5	P3	15	135,2 x 53,7 x 191,5 cm	24,6 x 48,9 x 56,5 cm	K3M5P3	
	M6	P3	18	161,7 x 53,7 x 191,5 cm	24,6 x 48,9 x 56,5 cm	K3M6P3	
	M1	P4	4	29,4 x 53,7 x 191,5 cm	24,6 x 48,9 x 41,8 cm	K3M1P4	
	M2	P4	8	55,7 x 53,7 x 191,5 cm	24,6 x 48,9 x 41,8 cm	K3M2P4	
	M3	P4	12	82,2 x 53,7 x 191,5 cm	24,6 x 48,9 x 41,8 cm	K3M3P4	
	M4	P4	16	108,7 x 53,7 x 191,5 cm	24,6 x 48,9 x 41,8 cm	K3M4P4	
	M5	P4	20	135,2 x 53,7 x 191,5 cm	24,6 x 48,9 x 41,8 cm	K3M5P4	
	M6	P4	24	161,7 x 53,7 x 191,5 cm	24,6 x 48,9 x 41,8 cm	K3M6P4	
	M1	P5	5	29,4 x 53,7 x 191,5 cm	24,6 x 48,9 x 33 cm	K3M1P5	
	M2	P5	10	55,7 x 53,7 x 191,5 cm	24,6 x 48,9 x 33 cm	K3M2P5	
	M3	P5	15	82,2 x 53,7 x 191,5 cm	24,6 x 48,9 x 33 cm	K3M3P5	
	M4	P5	20	108,7 x 53,7 x 191,5 cm	24,6 x 48,9 x 33 cm	K3M4P5	
	M5	P5	25	135,2 x 53,7 x 191,5 cm	24,6 x 48,9 x 33 cm	K3M5P5	
	M6	P5	30	161,7 x 53,7 x 191,5 cm	24,6 x 48,9 x 33 cm	K3M6P5	

NOTA: Las taquillas se suministran desmontadas, techo, suelo, laterales y fondo. El ensamblaje se realiza, encajando los dos laterales al fondo y uniendo mediante 12 tornillos el techo, el suelo y la puerta (tiempo 5 min.).

NOTE: All lockers are provided disassembled, roof, walls and floor. The assembling works fitting both walls to the back-side and fixing through 12 screws the roof, floor and door (5 min.).

NOTE: Toutes les casiers sont fournis sans monter, plafond, sol, fond et murs. Pour de monter, encaisser des murs au le fond et ajuster moyennant 12 visés au plafond, sol et porte (5 min.).

Accesorios / Accessories / Accessoires

1/2 Estante / 1/2 Shelve / 1/2 Étagère

1 Estante / 1 Shelve / 1 Étagère

Barra de colgar / Holding rail / Garde-robe

Patas regulables / Adjustable foot / Pied réglable

Zócalo 1 módulo lateral / Baseboard 1 lateral module / Plinthe 1 module central

Zócalo módulo central / Baseboard central module / Plinthe module central

Muñequera llave numerada / Numbered bracelet / Braclet numérée

Numeración placa de 30 x 15 / Sheet numeration of 30 x 15 / Numération plaque 30 x 15

Techo inclinado 1 módulo laterales / Sloping roof lateral modules / Plafond incliné module lateral

Techo inclinado 1 módulo central / Sloping roof central modules / Plafond incliné module central

Cerradura de seguridad / Safe lock / Verrouillage de sécurité

Cerradura de monedas / Coins lock / Verrouillage avec des pièces

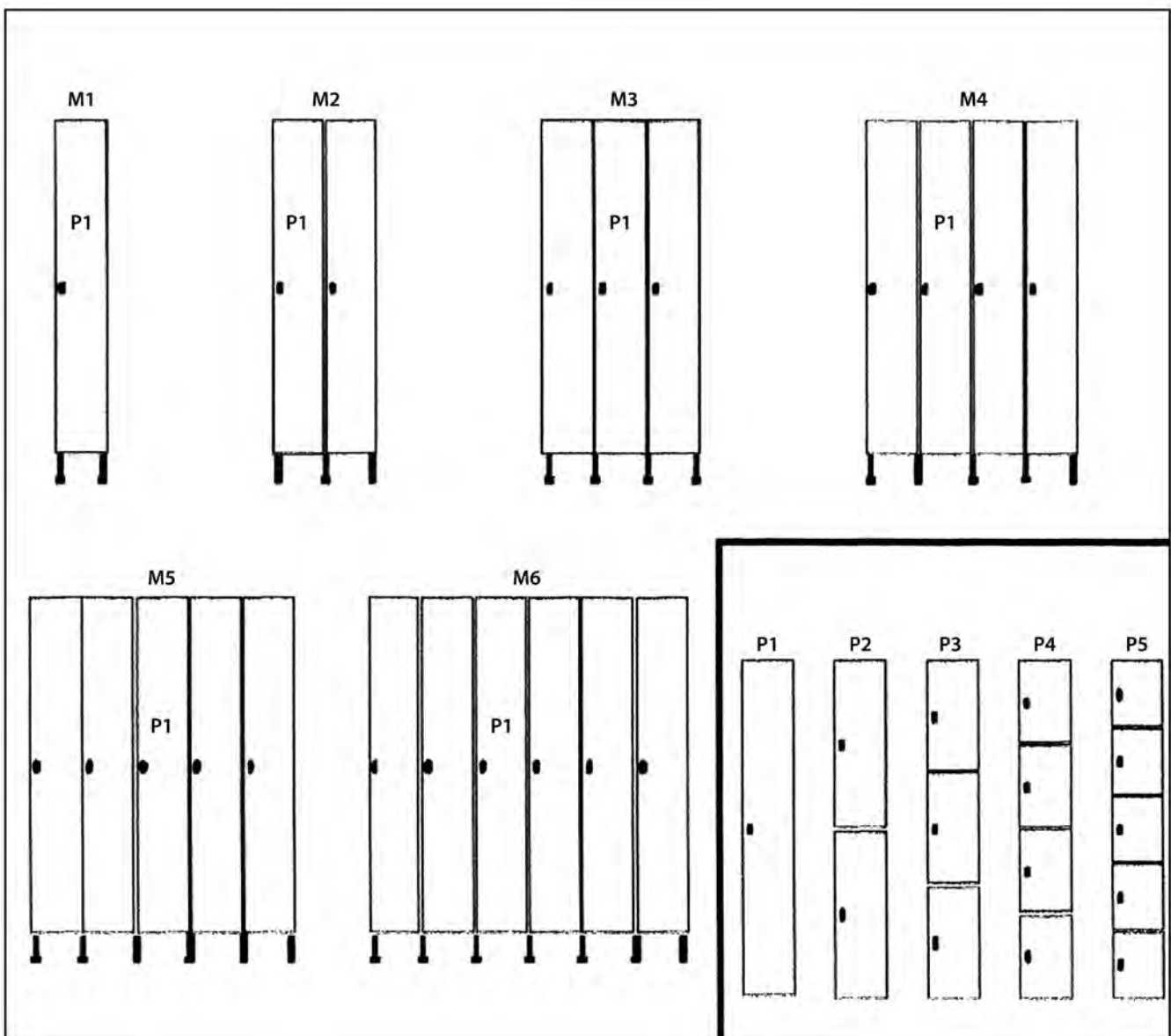

GAMA 400
 Cerradura de tipo pitones con 3.120 nº de combinaciones.
 Cierre central y posibilidad de amaestramiento.
 Color carcás en gris.
 Color de la puerta en azul, rojo, beige o gris claro.





Material resinas de polivinilo.
 Patas regulables de 13 a 18 cms.
 Clasificación M1 según norma UNE 23727.

GAMA 400
 Cerradura de tipo pitones con 3.120 nº de combinaciones.
 Cierre central y posibilidad de amaestramiento.
 Color carcás en gris.
 Color de la puerta en azul, rojo, beige o gris claro.

Material resinas de polivinilo.
 Patas regulables de 13 a 18 cms.
 Clasificación M1 según norma UNE 23727.

GAMA 400
 Cerradura de tipo pitones con 3.120 nº de combinaciones.
 Cierre central y posibilidad de amaestramiento.
 Color carcás en gris.
 Color de la puerta en azul, rojo, beige o gris claro.

Material resinas de polivinilo.
 Patas regulables de 13 a 18 cms.
 Clasificación M1 según norma UNE 23727.

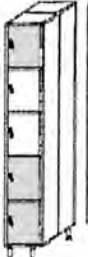
	Módulo Module Module	Puerta Door Porte	Nº de Puertas Nº of doors Nº de portes	Medidas exterior total Total external size Dimension extérieure totale	Hueco útil por taquilla Useful space Creux utile	Ref.	Accesorios incluidos Accessories included Accessoires inclus	
	M1	P1	1	39,5 x 53,7 x 191,5 cm	34,6 x 48,9 x 174 cm	K4M1P1		
	M2	P1	2	76,2 x 53,7 x 191,5 cm	34,6 x 48,9 x 174 cm	K4M2P1		
	M3	P1	3	112,9 x 53,7 x 191,5 cm	34,6 x 48,9 x 174 cm	K4M3P1	1/2 Estante y barra Shelve and holding rail Étagere et garde- robe	
	M4	P1	4	149,6 x 53,7 x 191,5 cm	34,6 x 48,9 x 174 cm	K4M4P1		
	M5	P1	5	186,3 x 53,7 x 191,5 cm	34,6 x 48,9 x 174 cm	K4M5P1		
	M6	P1	6	223 x 53,7 x 191,5 cm	34,6 x 48,9 x 174 cm	K4M6P1		
	M1	P2	2	39,5 x 53,7 x 191,5 cm	34,6 x 48,9 x 85,9 cm	K4M1P2		
	M2	P2	4	76,2 x 53,7 x 191,5 cm	34,6 x 48,9 x 85,9 cm	K4M2P2		
	M3	P2	6	112,9 x 53,7 x 191,5 cm	34,6 x 48,9 x 85,9 cm	K4M3P2	Barra de colgar Holding rail Garde-robe barre	
	M4	P2	8	149,6 x 53,7 x 191,5 cm	34,6 x 48,9 x 85,9 cm	K4M4P2		
	M5	P2	10	186,3 x 53,7 x 191,5 cm	34,6 x 48,9 x 85,9 cm	K4M5P2		
	M6	P2	12	223 x 53,7 x 191,5 cm	34,6 x 48,9 x 85,9 cm	K4M6P2		
	M1	P3	3	39,5 x 53,7 x 191,5 cm	34,6 x 48,9 x 56,5 cm	K4M1P3		
	M2	P3	6	76,2 x 53,7 x 191,5 cm	34,6 x 48,9 x 56,5 cm	K4M2P3		
	M3	P3	9	112,9 x 53,7 x 191,5 cm	34,6 x 48,9 x 56,5 cm	K4M3P3		
	M4	P3	12	149,6 x 53,7 x 191,5 cm	34,6 x 48,9 x 56,5 cm	K4M4P3		
	M5	P3	15	186,3 x 53,7 x 191,5 cm	34,6 x 48,9 x 56,5 cm	K4M5P3		
	M6	P3	18	223 x 53,7 x 191,5 cm	34,6 x 48,9 x 56,5 cm	K4M6P3		
	M1	P4	4	39,5 x 53,7 x 191,5 cm	34,6 x 48,9 x 41,8 cm	K4M1P4		
	M2	P4	8	76,2 x 53,7 x 191,5 cm	34,6 x 48,9 x 41,8 cm	K4M2P4		
	M3	P4	12	112,9 x 53,7 x 191,5 cm	34,6 x 48,9 x 41,8 cm	K4M3P4		
	M4	P4	16	149,6 x 53,7 x 191,5 cm	34,6 x 48,9 x 41,8 cm	K4M4P4		
	M5	P4	20	186,3 x 53,7 x 191,5 cm	34,6 x 48,9 x 41,8 cm	K4M5P4		
	M6	P4	24	223 x 53,7 x 191,5 cm	34,6 x 48,9 x 41,8 cm	K4M6P4		
	M1	P5	5	39,5 x 53,7 x 191,5 cm	34,6 x 48,9 x 33 cm	K4M1P5		
	M2	P5	10	76,2 x 53,7 x 191,5 cm	34,6 x 48,9 x 33 cm	K4M2P5		
	M3	P5	15	112,9 x 53,7 x 191,5 cm	34,6 x 48,9 x 33 cm	K4M3P5		
	M4	P5	20	149,6 x 53,7 x 191,5 cm	34,6 x 48,9 x 33 cm	K4M4P5		
	M5	P5	25	186,3 x 53,7 x 191,5 cm	34,6 x 48,9 x 33 cm	K4M5P5		
	M6	P5	30	223 x 53,7 x 191,5 cm	34,6 x 48,9 x 33 cm	K4M6P5		

NOTA: Las taquillas se suministran desmontadas, techo, suelo, laterales y fondo. El ensamblaje se realiza, encajando los dos laterales al fondo y uniendo mediante 12 tornillos el techo, el suelo y la puerta (tiempo 5 min.).

NOTE: All lockers are provided disassembled, roof, walls and floor. The assembling works fitting both walls to the back-side and fixing through 12 screws the roof, floor and door (5 min.).

NOTE: Toutes les casiers sont fournis sans monter, plafond, sol, fond et murs. Pour de monter, encaisser des murs au le fond et ajuster moyennant 12 visés au plafond, sol et porte (5 min.).

GAMA 400 D Vertical
Cerradura de tipo pitones con 3.120 n° de combinaciones.
Cierre central y posibilidad de amaestramiento.
Color carcás en gris.
Color de la puerta en azul, rojo, beige o gris claro.



GAMA 400 D Vertical
 Cerradura de tipo pitones con 3.120 n° de combinaciones.
 Cierre central y posibilidad de amaestramiento.
 Color carcás en gris.
 Color de la puerta en azul, rojo, beige o gris claro.

GAMA 400 D Vertical
 Cerradura de tipo pitones con 3.120 n° de combinaciones.
 Cierre central y posibilidad de amaestramiento.
 Color carcás en gris.
 Color de la puerta en azul, rojo, beige o gris claro.

Material resinas de polivinilo.
Patas regulables de 13 a 18 cms.
Clasificación M1 según norma UNE 23727.

Material resinas de polivinilo.
 Patas regulables de 13 a 18 cms.
 Clasificación M1 según norma UNE 23727.

Material resinas de polivinilo.
 Patas regulables de 13 a 18 cms.
 Clasificación M1 según norma UNE 23727.

	Módulo Module	Puerta Door Porte	N° de Puertas N° of doors N° de portes	Medidas exterior total Total external size Dimension extérieure totale	Hueco útil por taquilla Useful space Creux utile	Ref.	Accesorios incluidos Accessories included Accessoires inclus
	M1	P1	1	39,5 x 53,7 x 191,5 cm	16,2 x 48,9 x 174 cm	KD4M1P1	
	M2	P1	2	76,2 x 53,7 x 191,5 cm	16,2 x 48,9 x 174 cm	KD4M2P1	<i>Estante, barra y división vertical Shelve, rail and vertical wall Étagèr, barre et séparateur</i>
	M3	P1	3	112,9 x 53,7 x 191,5 cm	16,2 x 48,9 x 174 cm	KD4M3P1	
	M4	P1	4	148,7 x 53,7 x 191,5 cm	16,2 x 48,9 x 174 cm	KD4M4P1	
	M5	P1	5	186,3 x 53,7 x 191,5 cm	16,2 x 48,9 x 174 cm	KD4M5P1	
	M6	P1	6	223 x 53,7 x 191,5 cm	16,2 x 48,9 x 174 cm	KD4M6P1	
	M1	P2	2	39,5 x 53,7 x 191,5 cm	16,2 x 48,9 x 85,9 cm	KD4M1P2	
	M2	P2	4	75,7 x 53,7 x 191,5 cm	16,2 x 48,9 x 85,9 cm	KD4M2P2	
	M3	P2	6	112,2 x 53,7 x 191,5 cm	16,2 x 48,9 x 85,9 cm	KD4M3P2	
	M4	P2	8	148,7 x 53,7 x 191,5 cm	16,2 x 48,9 x 85,9 cm	KD4M4P2	
	M5	P2	10	155,2 x 53,7 x 191,5 cm	16,2 x 48,9 x 85,9 cm	KD4M5P2	
	M6	P2	12	221,7 x 53,7 x 191,5 cm	16,2 x 48,9 x 85,9 cm	KD4M6P2	

NOTA: Las taquillas se suministran desmontadas, techo, suelo, laterales y fondo. El ensamblaje se realiza, encajando los dos laterales al fondo y uniéndolo mediante 12 tornillos el techo, el suelo y la puerta (tiempo 5 min.).

NOTE: All lockers are provided disassembled, roof, walls and floor. The assembling works fitting both walls to the back-side and fixing through 12 screws the roof, floor and door (5 min.).

NOTE: Toutes les casiers sont fournis sans monter, plafond, sol, fond et murs. Pour de monter, encaisser des murs au le fond et ajuster moyennant 12 visés au plafond, sol et porte (5 min.).

Accesorios / Accessories / Accessoires

1/2 Estante / 1/2 Shelve / 1/2 Étagère

1 Estante / 1 Shelve / 1 Étagère

Barra de colgar / Holding rail / Garde-robe

Patas regulables / Adjustable foot / Pied réglable

Zócalo 1 módulo lateral / Baseboard 1 lateral module / Plinthe 1 module central

Zócalo módulo central / Baseboard central module / Plinthe module central

Muñequera llave numerada / Numbered bracelet / Braçlet numéree

Numeración placa de 30 x 15 / Sheet numeration of 30 x 15 / Numérotation plaque 30 x 15

Techo inclinado 1 módulo laterales / Sloping roof lateral modules / Plafond incliné module lateral

Techo inclinado 1 módulo central / Sloping roof central modules / Plafond incliné module central

Cerradura de seguridad / Safe lock / Verrouillage de sécurité

Cerradura de monedas / Coins lock / Verrouillage avec des pièces

NOTA: Las taquillas se suministran desmontadas, techo, suelo, laterales y fondo. El ensamblaje se realiza, encajando los dos laterales al fondo y uniéndolo mediante 12 tornillos el techo, el suelo y la puerta (tiempo 5 min.).

NOTE: All lockers are provided disassembled, roof, walls and floor. The assembling works fitting both walls to the back-side and fixing through 12 screws the roof, floor and door (5 min.).

NOTE: Toutes les casiers sont fournis sans monter, plafond, sol, fond et murs. Pour le monter, encaisser des murs au le fond et ajuster moyennant 12 visés au plafond, sol et porte (5 min.).

Recambios

Carteles portaprecios, Guantes acero-inox, Indicadores de turno, Grifos ducha, Soldadores de bolsa, Esterilizadores, Máquinas retractilar, Máquinas cierra bolsas, Hamburgueseras, Máquinas cierra bolsas, Etiquetadoras, Abrelatas, Exterminadores-tubos.

Spare Parts

Tag holders, Stainless steel gloves, Queue indicators, Shower taps, Bag sealers, Sterilisers, Wrapping machines, Burguer presses, Labellers, Can opener, Insect exterminators-tubes.

Pieces de Rechange

Affiches porte-prix, Gants d'inox, Indicateurs de tour, Robinets douche, Scelleuse de sacs, Stérilisateurs, Machines à retractiler, Machine ferme sacs, Hachoirs, Étiqueteusses, Ouvre-boîtes, Exterminateurs d'insectes-tubes.

Números

Numbers

Numerós

Ref.	Para For Pour
C-103	C-26
C-104	C-27, C-28, C-50
C-108	C-19, C-20, C-21, C-25, C-35, C-40, C-41, C-52
C-110	C-31, C-32, C-33
C-115	C-30, C-34

Números (Caja 24 juegos números / Ref. C-121 números dobles)

Numbers (Box with 24 sets of numbers / Ref. C-121 double numbers)

Numerós (Boîte avec 24 jeux de numéros / Ref. C-121 numéros doubles)

Ref.	Para For Pour
C-121	C-44
C-122	C-42

GUANTES ACERO INOXIDABLE | STAINLESS STEEL GLOVES | *GANTS D'ACIER INOX*

Banda plástico

Plastic band

Bande plastique

Ref.	Color Colour Couleur
A-1050-B	●
A-1051-B	●
A-1052-B	○

Ref.	Color Colour Couleur
A-1053-B	●
A-1054-B	●
A-1055-B	●

INDICADORES DE TURNO | QUEUE INDICATORS | *INDICATEURS DE TOUR*

Soporte pared

Wall holder

Support par mur

Ref.	Para For Pour
ET-108	ET-1

Caja control

Control pad with cable

Télécommande avec fil pour

Ref.	Para For Pour
IT-103	IT-4, IT-6

Caja control

Control pad with cable

Commande avec fil pour

Ref.	Para For Pour
IT-110	IT-8

Mando a distancia

Remote control

Télécommande

Ref.	Para For Pour
IT-105	IT-5-MD

Mando a distancia

Remote control

Télécommande

Ref.	Para For Pour
IT-105-	IT-7-MD

Mando a distancia con visor

Remote control

Télécommande

Ref.	Para For Pour
IT-105-V	IT-5-MDV

Mando a distancia (1 función)

Remote control (1 function)

Télécommande (1 fonction)

Ref.	Para For Pour
IT-107	IT-4-MD, IT-6-MD, IT-5-MD

Mando a distancia (2 funciones)

Remote control (2 functions)

Télécommande (2 fonctions)

Ref.	Para For Pour
IT-106	IT-6-MD, IT-8-MD

Mando a distancia (3 funciones)

Remote control (3 functions)

Télécommande (3 fonctions)

Ref.	Para For Pour
IT-109	IT-4-MD

**Resistencia y teflón**

Heating element and teflon cloth

Élément coupant et téflon

Ref.	Para For Pour
SB-201	SB-200
SB-301	SB-300
SB-401	SB-400
SB-501	SB-500

Resistencia

Resistance

Résistance

Ref.	Para For Pour
SBPA-451	SBPA-450
SBPA-601	SBPA-600

Termóstato

Thermostat

Thermostat

Ref.	Para For Pour
SB-202	SB-200
SB-302	SB-300
SB-402	SB-400
SB-502	SB-500

Rollo teflón

Teflon cloth roll

Rouleau de téflon

Ref.	Para For Pour
SB-602	SBP-450/600, SBM-600

Resistencia

Heating element

Élément coupant

Ref.	Para For Pour
SB-451	SBP-450
SB-601	SBP-600, SBM-600, SB-600
SB-1001	SB-1000

ESTERILIZADORES | STERILISERS | STÉRILISATEURS**Circuito eléctrico completo temporizado**

Complete electric circuit

Circuit électrique complet

Ref.	Para For Pour
EC-710	EC-1, EC-55, EC-105

Base conexión macho con toma red + portafusible

Plug connection with power point + fuse carrier

Base connection prise + portafusible

Ref.	Para For Pour
EC-711	EC-1, EC-55, EC-105

Pulsador redondo para encendido

On button

Bouton de branchement

Ref.	Para For Pour
EC-712	EC-1, EC-55, EC-105

ESTERILIZADORES | STERILISERS | STÉRILISATEURS**Cable de corriente**

Power cable

Cable courant électrique

Ref.	Para For Pour
EC-713	EC-1, EC-55, EC-105

Fusible

Fuse

Fusible

Ref.	Para For Pour
EC-714	EC-1, EC-55, EC-105

Lámpara ozono con soporte

Ozone lamp with stand

Lampe d'ozone avec support

Ref.	Para For Pour
EC-715	EC-1, EC-55, EC-105

Lámpara UV germicida 15 W

UV germicide lamp 15 W

Lampe UV germicide 15 W

Ref.	Para For Pour
ECU-15	ECU-25, ECU-50, ECU-100

Resistencia de corte

Heating element

Élément coupant

Ref.	Para For Pour
MR-201	MR-2, MR-4
MR-201-ECO	MR-4-ECO
MR-206	MR-4-500
MR-206-ECO	MR-4-500-ECO

Termostato

Thermostat

Thermostat

Ref.	Para For Pour
MR-203	MR-4, MR-4-500

Interruptor general

General switch

Interrupteur général

Ref.	Para For Pour
MR-207	MR-4, MR-4-500

Resistencia de corte

Heating element

Élément coupant

Ref.	Para For Pour
MR-210	MR-4-600
MR-215	MR-3

Rueda termostato

Thermostat wheel

Roulette de thermostat

Ref.	Para For Pour
MR-204	MR-4, MR-4-500

Interruptor placa de calor o resistencia

Heat plate and heating élément on/off switch

Interrupteur pour element coupant et plaque de chauffage

Ref.	Para For Pour
MR-208	MR-4, MR-4-500

Placa de calor

Heat plate

Plaque de chauffage

Ref.	Para For Pour
MR-202	MR-4, MR-4-500
MR-202-ECO	MR-4-ECO

Portafusible con fusible

Fuse carrier with fuse

Portafusible avec fusible

Ref.	Para For Pour
MR-205	MR-4, MR-4-500

Piloto señalización

Sign light

Lumineux

Ref.	Para For Pour
MR-209	MR-4, MR-4-500

MÁQUINAS CIERRA BOLSAS | BAG SEALERS | MACHINE FERME SACS

Rueda rollo

Roll wheel

Roulette rouleau

Ref.	Para For Pour
CB-10	CB-101

Rueda rollo

Roll wheel

Roulette rouleau

Ref.	Para For Pour
CB-11	CB-606

HAMBURGUESERAS | BURGUER PRESSES | HACHOIRS

Palanca prensa

Press lever

Levier presse

Ref.	Para For Pour
MH-101	MH-2

Pala doble

Double slice

Pelle double

Ref.	Para For Pour
MH-102	MH-2
MH-105	MH-3, MH-4

Pala doble redonda

Round double slice

Pelle double ronde

Ref.	Para For Pour
MH-107	MH-5
MH-6-1	MH-6
MH-7-1	MH-7
MH-8-1	MH-8
MH-9-1	MH-9

Pala ovalada

Oval shovel

Pelle oval

Ref.	Para For Pour
MH-111	MH-1

Pala redonda

Round shovel

Pelle ronde

Ref.	Para For Pour
MH-112	MH-1-R

Muelle elevación placa

Elevator sheet spring

Ressort elevateur plaque

Ref.	Para For Pour
MH-104	MH-2
MH-110	MH-3, MH-4

Muelle elevación brazo

Elevator arm spring

Ressort elevateur bras

Ref.	Para For Pour
MH-103	MH-2

Muelle elevación brazo izquierdo

Elevator left arm spring

Ressort elevateur bras gauche

Ref.	Para For Pour
MH-108	MH-3, MH-4

Muelle elevación brazo derecho

Elevator right arm spring

Ressort elevateur bras droite

Ref.	Para For Pour
MH-109	MH-3, MH-4

ETIQUETADORAS | LABELLERS | ÉTIQUETEUSES

Rodillo tinta

Ink roller

Rouleau encre

Ref.	Para For Pour
E-110	E-5, E-6

Rodillo tinta

Ink roller

Rouleau encre

Ref.	Para For Pour
E-110-ECO	E-5-ECO, E-6-ECO

Cuchilla

Blade

Lame

Ref.	Para For Pour
A-70-1	A-70

Roldana o rueda de arrastre

Wheel for drag

Roulette pour traîner

Ref.	Para For Pour
A-70-2	A-70

Muelle de roldana

Spring of A-70-2 for ref. A-70

Ressort de A-70-2 pour réf. A-70

Ref.	Para For Pour
A-70-3	A-70

ABRELATAS | CAN OPENER | OUVRE-BOÎTES

Tubo

Tube

Tube

Ref.	Tipo Type Type	Para For Pour
Z-10	10 W	Z-420-MD
Z-11	11 W	Z-600
Z-15	15 W	Z-700, Z-930, Z-950, Z-430-MD
Z-20	20 W	Z-740, Z-840, Z-960
Z-20-F	18 W	Z-440-MD
Z-40	40 W	Z-780, Z-880

Tubo, forma U

Tube, U form

Tube, forme d'U

Ref.	Tipo Type Type	Para For Pour
Z-11-U	11 W	Z-151

Lámpara bajo consumo

Low energy lamp

Lampe de basse consommation

Ref.	Tipo Type Type	Para For Pour
Z-21	20 W	Z-911, Z-918

0-9					
0,3 CM2	9	3200.300-R	170	A-17-NV	180
0010.100	168	3200.300-V	170	A-17-P	180
0015.065	168	3250.300-A	170	A-18	174
0151.310	162	3250.300-AZ	170	A-198	85
0151.355	162	3250.300-N	170	A-198-1	85
0151.395	162	3250.300-R	170	A-2	174
0170.155	162	3250.300-V	170	A-20	144
0170.185	162	3400.300	170	A-200	86
0170.210	162	3500.300	170	A-2001	177
0170.260	162	3900.700	171	A-200-13	86
0170.310	162	3900.750	171	A-200-13X Circonio	86
0170.355	162	3900.995	171	A-2002	177
0170.395	162	4 CM2	9	A-2003	177
0370.165	162	4000.100	164	A-200-33	86
0370.195	162	4000.150	164	A-2004	177
0370.225	162	4000.200	164	A-21	173
0425.130	162	4000.250	164	A-22	173
0425.150	162	4000.300	164	A-23	144
0430.150	163	4010.150	164	A-24	144
0500.305	163	4020.300	164	A-25	173
0521.250	164	4050.180	164	A-26	144
0521.300	164	4100.150	165	A-27	142
0526.250	163	4100.200	164	A-28	142
0526.300	163	4100.250	164	A-29	142
0540.250	163	4101.250	165	A-3	142
0540.305	163	4102.230	165	A-3000	178
0560.250	168	4105.180	165	A-3005	178
0560.310	168	4120.250	164	A-30-100	18
0575.250	168	4120.300	164	A-30-100-I	18
0575.300	168	4200.150	165	A-30-50	18
0575.360	168	4200.200	165	A-30-50-I	18
0600.300	165	4200.250	165	A-30-70	18
0600.350	165	4200.280	165	A-30-70-I	18
0701.320	163	4300.270	165	A-35-11	72
0701.350	163	5 CM2	9	A-35-13	72
0701.370	163	9 CM2	9	A-35-15	72
0720.350	163	A		A-35-26	72
0720.380	163	A-1	41	A-36-11	72
0775.190	163	A-1000	176	A-36-13	72
0801.230	166	A-1001	176	A-36-15	72
0801.250	166	A-1020	176	A-37	139
0801.290	166	A-1021	176	A-38-G	181
0820.240	166	A-1022	176	A-38-M	181
0820.260	166	A-1023	176	A-38-P	181
0840.320	166	A-1024	176	A-41	17
0850.220	166	A-1050	176	A-4-11	144
0850.250	166	A-1050-B	198	A-4-14	144
0901.290	167	A-1050-X	176	A-4-16	144
0901.310	167	A-1051	176	A-42	17
0905.290	167	A-1051-B	198	A-4-20	144
0905.310	167	A-1051-X	176	A-4-24	144
1,5 CM2	9	A-1052	176	A-43	17
1000.305	167	A-1052-B	198	A-43-P	17
1000.450	167	A-1052-X	176	A-44	17
1001.260	167	A-1053	176	A-44-P	17
1001.290	167	A-1053-B	198	A-46	17
1001.320	167	A-1053-X	176	A-47	17
14 CM2	9	A-1054	176	A-48-18	16
1701.135	168	A-1054-B	198	A-48-22	16
1705.150	168	A-1054-X	176	A-48-26	16
1CM2	9	A-1055	176	A-49	145
2 CM2	9	A-1055-B	198	A-50	145
2002.250	167	A-1055-X	176	A-50-15	145
2002.310	167	A-1110	176	A-50-25	145
2401.230	168	A-1111	176	A-50-30	145
2401.260	168	A-11-110	180	A-51	173
2460.400	174	A-1112	176	A-5-12	144
2460.450	174	A-11-120-AZ	180	A-5-16	144
2460.500	174	A-1113	176	A-52	173
2476.420	174	A-1114	176	A-5-20	144
2476.450	174	A-1115	176	A-5-24	144
2476.500	174	A-11-90	180	A-53	173
2500.330	174	A-11-90-AZ	180	A-530	132
2500.450	174	A-11-90-N	180	A-531	132
2500.600	174	A-11-90-R	180	A-54	173
2526.000	168	A-12	181	A-540	133
3 CM2	9	A-14	173	A-550	133
3000.200	169	A-15	146	A-555	133
3000.250	169	A-16	172	A-56	174
3000.300	169	A-17-B	180	A-57	18
3050.300	169	A-17-BAZ	180	A-6	172
3100.300	169	A-17-BR	180	A-65	175
3150.300	169	A-17-BU	180	A-70	175
3200.300-A	170	A-17-BV	180	A-70-1	201
3200.300-AZ	170	A-17-F	180	A-70-2	201
3200.300-N	170	A-17-N	180	A-70-3	201
		A-17-NBU	180	A-75	94
				A-76	95
				A-77	95
				A-8	144
				A-80	2
				A-81	2
				A-81-1	2
				A-82 (CONSULTAR)	182
				A-83 polipropileno	182
				A-83-X polietileno	182
				A-84	182
				A-85	182
				A-86	182
				A-87 (CONSULTAR)	182
				A-89 CONSULTAR)	182
				A-90	113
				A-95	113
				A-9-76M	179
				B	
				BA-3	48
				BA-5	48
				BAC-1	155
				BAC-1	48
				BAL-1	48
				BAL-1	155
				BB-1	47
				BB-10	47
				BB-2	47
				BB-3	47
				BB-4	47
				BB-5	47
				BB-6	47
				BB-7	47
				BB-8	47
				BB-9	47
				BBP-1	47
				BBP-2	47
				BBP-3	47
				BBP-4	47
				BBP-5	47
				BC-0	49
				BC-0-N	49
				BC-1	49
				BC-1-N	49
				BC-2	49
				BC-2-N	49
				BC-3	49
				BC-3-N	49
				BC-4	49
				BC-4-N	49
				BC-5	49
				BCR-0	49
				BCR-1	49
				BCR-2	49
				BCR-3	49
				BCR-4	49
				BCR-5	49
				BCR-5-N	49
				BCT-0	49
				BCT-1	49
				BCT-2	49
				BCT-3	49
				BI-11	50
				BI-12	50
				BI-13	50
				BI-14	50
				BI-15-B	155
				BI-15-B	50
				BI-15-N	50
				BI-15-N	155
				BI-15-R	50
				BI-15-R	155
				BI-21	50
				BI-21-N	50
				BI-22	50
				BI-22-N	50
				BI-23	50
				BI-23-N	50
				BP-10063-N	58
				BP-14330-N	60
				BP-1946-N	60
				BP-4013-N	58
				BP-5355-N	58
				BP-5356-N	59
				BP-5869-N	59
				BP-5921-N	59
				BP-6661-N	58
				BP-6665-N	58

B-D

BP-6670-N	58	BVC-350500	97	C-30	38	C-7-B	28
BP-6675-N	58	BVE-200300	96	C-300	22	C-81	28
BP-6901-N	60	BVE-250350	96	C-301	22	C-82	28
BP-6960-N	58	BVE-300400	96	C-302	22	C-87	34
BP-9327-N	60	BVE-350450	96	C-303	22	C-87-A	34
BPA-15-50-N	57	BVE-350600	96	C-304	22	C-88	34
BPA-22G-50-N	56	BVP-175250	96	C-305	22	C-89	34
BPA-22P-50-N	57	BVP-175300	96	C-306	22	C-9	35
BPA-45-50-N	56	BVP-200250	96	C-307	22	C-90-AZ	26
BPA-90-50-N	57	BVP-200300	96	C-30-P	38	C-90-B	26
BPA-90-50-N	56	BVPO-200300	96	C-31	38	C-90-R	26
BPA-ANFI	57	BVPP-200300	96	C-310	22	C-91	28
BPA-ANFI	56	BVX-1525	95	C-311	23	C-92	28
BPA-TD-50-N	56	BVX-1535	95	C-312	23	C-93	34
BPA-TD-50-N	57	BVX-1545	95	C-313	23	C-94	34
BPA-TI-50-N	57	BVX-2020	95	C-314	23	C-95	34
BPA-TI-50-N	56	BVX-2030	95	C-315	23	C-96	34
BPB-10569-N	59	BVX-2040	95	C-317	23	C-97	28
BPB-17068-N	59	BVX-2535	95	C-32	38	C-97-N	28
BPB-17069-N	60	BVX-3040	95	C-320	32	C-98	28
BPB-17070-N	60	BVX-3050	95	C-320	23	C-98-N	28
BPB-17071-N	60	BVXC-200300	95	C-321	25	C-99	29
BPB-25140	59	BVX-R20	95	C-33	38	CB-10	200
BPB-9232-N	59	BX-4	46	C-34	32	CB-101	150
BPC-22860-N	61	BX-5	46	C-35	32	CB-11	200
BPC-22861-N	61	BX-6	46	C-35-K	32	CB-606	150
BPC-22866-N	61	BX-9	46	C-38	25	CB-800	150
BPC-24544-N	61	BXP-2	46	C-38-B	27	CC-10	45
BP-GN 1/1-50-N	54	BXP-3	46	C-39	29	CC-100	45
BP-GN 1/2-50-N	54	BXP-4	46	C-40	32	CC-12	45
BP-GN 1/3-17-N	54	BXP-5	46	C-41	32	CC-14	44
BP-GN 1/3-50-N	54	BZ-1	46	C-42-AZ	30	CC-15	45
BP-GN 1/4-17-N	54	BZ-10	46	C-42-B	31	CC-16	45
BP-GN 1/4-50-N	54	BZ-2	46	C-42-C	31	CC-19	45
BP-GN 1/5-17-N	54	BZ-3	46	C-42-G	29	CC-20	45
BP-GN 1/5-50-N	54	BZ-4	46	C-42-GAZ	29	CC-21	45
BP-GN 1/6-50-N	54	BZ-5	46	C-42-GM	29	CC-32	44
BP-GN 1/9-50-N	54	BZ-6	46	C-42-GR	29	CC-33	45
BP-GN 2/4-17-N	54	BZP-1	46	C-42-R	31	CC-40	45
BP-GN 2/5-17-N	54	BZP-2	46	C-42-V	31	CC-60	45
BP-GN 3/4-17-N	54	BZP-3	46	C-43	31	CC-9	45
BP-GN 3/4-50-N	54	BZP-4	46	C-43-A	31	CCT-39	45
BP-GN 5/4-40-N	54	C		C-44-AZ	30	CCT-40	45
BP-GN 1/1-17-N	54	C-1	35	C-44-B	30	CCT-60	45
BP-GN 1/2-17-N	54	C-10	24	C-44-BAZ	30	CH-1	45
BPR-1/1-N	55	C-100	29	C-44-BR	30	CH-10	44
BPR-1/2-N	55	C-103	198	C-44-BV	30	CH-100	44
BPR-1/3-N	55	C-104	198	C-44-C	30	CH-12	44
BPR-1/4-N	55	C-108	198	C-44-M	30	CH-18	44
BPR-1/5-N	55	C-10-AZ	24	C-44-R	30	CH-2	45
BPT-1/1-T	55	C-10-B	24	C-4-B	35	CH-3	45
BPT-1/2-T	55	C-11	24	C-4-M	35	CH-30	44
BPT-1/3-T	55	C-110	198	C-500	39	CH-4	45
BPT-1/4-T	55	C-115	198	C-51	31	CH-40	44
BPT-1/5-T	55	C-11-AZ	24	C-56	31	CH-50	44
BPT-2/5-T	55	C-11-B	24	C-57	37	CH-6	45
BPT-3/4-T	55	C-121	198	C-62	38	CH-7	45
BPT-4015	58	C-122	198	C-63	38	CH-75	44
BPT-6680	58	C-13	26	C-64	38	CP-12	71
BPTR-27-20-N	55	C-130	28	C-65-AZ	24	CP-12- 3;5	71
BPTR-40-20-N	55	C-131	28	C-65-AZB	27	CP-12-3	71
BPTR-40-50-N	55	C-132	26	C-65-B	25	CP-12-4	71
BV-140450	96	C-140	26	C-65-BB	27	CP-12-4;5	71
BV-150200	96	C-141	26	C-65-R	24	CP-12-5	71
BV-150250	96	C-15-N	25	C-65-RB	27	CP-12-6	71
BV-175250	96	C-17	25	C-65-V	24	CP-12-7	71
BV-180300	96	C-1-N	35	C-65-VB	27	CP-12-8	71
BV-200200	96	C-1-P	35	C-65-VF	32	CP-22	71
BV-200250	96	C-1PN	35	C-66	25	CP-22-3	71
BV-200300	96	C-2	29	C-66-B	27	CP-22-3;5	71
BV-200350	96	C-205	35	C-67	27	CP-22-4	71
BV-200400	96	C-210	36	C-67-AZ	27	CP-22-4;5	71
BV-250350	96	C-211	36	C-67-R	27	CP-22-5	71
BV-300400	96	C-212	36	C-68	32	CP-22-6	71
BV-350500	96	C-213	36	C-69	32	CP-22-7	71
BV-350600	96	C-214	36	C-7	29	CP-22-8	71
BV-400500	96	C-215-B	60	C-72	33	CP-2C	71
BV-400600	96	C-215-B	36	C-73	33	CP-2C	72
BVA-1	97	C-215-N	36	C-74	33	CP-2C	71
BVA-2	97	C-215-N	60	C-75	33	CP-32	72
BVA-3	97	C-24	25	C-76	33	CP-32-3	72
BVA-4	97	C-24-B	25	C-76-C	33	CP-32-3;5	72
BVC-150200	97	C-24-T	25	C-76-T	33	CP-32-4	72
BVC-185250	97	C-25	37	C-77	33	CP-32-4;5	72
BVC-200300	97	C-26	37	C-77-C	34	CP-32-5	72
BVC-250350	97	C-27	37	C-77-T	33	CP-32-6	72
BVC-300400	97	C-28	37	C-79	34	CP-32-7	72

CP-32-8	72	ET-100-P	127	GI-2/1-65	52	H-E12	146
CP-8	71	ET-100-S	127	GI-2/3-100	52	H-E14	146
CP-8-3	71	ET-108	198	GI-2/3-150	52	H-E16	146
CP-8-3;5	71	ET-15	127	GI-2/3-20	48	H-E18	146
CP-8-4	71	ET-1-A	128	GI-2/3-20	52	H-P23	147
CP-8-4;5	71	ET-1-AZ	128	GI-2/3-200	52	H-P23-C	147
CP-8-5	71	ET-1-B	128	GI-2/3-40	52	H-P33	147
CP-8-6	71	ET-1-G	128	GI-2/3-65	52	H-P33-C	147
CP-8-7	71	ET-1-N	128	GI-2/4-20	48	I	
CP-8-8	71	ET-1-NA	128	GIFP-1/1	54	IT-10	125
D		ET-1-R	128	GIFP-1/2	54	IT-10-1	125
D-1	106	ET-1-V	128	GIFP-2/1	54	IT-103	198
D-11	107	F		GIFP-2/3	54	IT-105	198
D-12	107	F-10	171	GIP-1/1-100	53	IT-105-	198
D-2	106	F-11	171	GIP-1/1-150	53	IT-105-V	198
D-4-B	106	F-12	171	GIP-1/1-20	53	IT-106	198
D-4-C	106	F-13	171	GIP-1/1-200	53	IT-107	198
D-50	107	F-14	171	GIP-1/1-40	53	IT-109	198
D-7	106	F-15	175	GIP-1/1-65	53	IT-11	125
D-7-N	106	F-16	175	GIP-1/2-100	53	IT-110	198
D-8	106	F-17	171	GIP-1/2-150	53	IT-11-1	125
DA-1	81	F-20	175	GIP-1/2-200	53	IT-30	126
DA-18	81	F-21	175	GIP-1/2-65	53	IT-30-MD	126
DB-10	80	F-22	175	GIP-2/1-20	53	IT-4	124
DB-6	80	F-35	169	GIP-2/1-40	53	IT-4-MD	124
DB-8	80	F-36	169	GIP-2/1-65	53	IT-4-X	125
DD-10	80	F-40	169	GIS-325	54	IT-5-MD	122
DD-20	80	G		GIS-530	54	IT-5-MDV	122
DD-8	80	G-0	142	GIT-1/1	53	IT-6	122
DE-1	80	G-00	142	GIT-1/2	53	IT-6-B	122
DE-10	80	G-1	142	GIT-1/3	53	IT-6-E	122
DE-14	80	G-10	142	GIT-1/4	53	IT-6-ECO	122
DE-2	80	G-11	142	GIT-1/6	53	IT-6-MD	123
DE-3	80	G-12	142	GIT-1/9	53	IT-6-MD-ECO	123
DE-4	80	G-13	142	GIT-2/3	53	IT-6-X	123
DE-5	80	G-14	143	GITH-1/1	53	IT-7-MD	123
DE-6	80	G-15	143	GITH-1/2	53	IT-8	123
DE-8	80	G-18	143	GITH-1/3	53	IT-8-MD	124
DH-10	81	G-19	143	GITH-1/4	53	IT-9-MD	124
DH-2;5	81	G-2	142	GITH-1/6	53	ITH-95	126
DH-4	81	G-20	143	GITH-2/3	53	ITR-125	126
DH-6	81	G-3	142	GP-1/1-100	51	K	
DH-8	81	G-4	142	GP-1/1-150	51	K-10	185
DR-0	78	G-5	142	GP-1/1-200	51	K-104	185
DR-2	78	G-6	142	GP-1/1-65	51	K-104-5	185
DR-3	78	G-7	142	GP-1/2-100	51	K-105	185
DR-4	78	G-8	142	GP-1/2-150	51	K-105-5	185
DR-6	78	G-9	142	GP-1/2-200	51	K-106	185
DR-8	78	GI-1/1-100	52	GP-1/2-65	51	K-106-5	185
DRH	78	GI-1/1-150	52	GP-1/3-100	51	K-124	185
DS-1	80	GI-1/1-20	52	GP-1/3-150	51	K-124-5	185
DS-2	80	GI-1/1-20	48	GP-1/3-200	51	K-125	185
DV	80	GI-1/1-200	52	GP-1/3-65	51	K-125-5	185
DX-1	81	GI-1/1-40	52	GP-1/4-100	51	K-126	185
DZ-2	80	GI-1/1-65	52	GP-1/4-150	51	K-126-5	185
DZ-3	80	GI-1/2-100	52	GP-1/4-200	51	K-15	185
DZ-4	80	GI-1/2-150	52	GP-1/4-65	51	K-154	185
DZ-7	80	GI-1/2-20	48	GP-1/6-100	51	K-154-5	185
E		GI-1/2-20	52	GP-1/6-150	51	K-155	185
E-110	151	GI-1/2-200	52	GP-1/6-200	51	K-155-5	185
E-110	201	GI-1/2-40	52	GP-1/6-65	51	K-156	185
E-110-ECO	151	GI-1/2-65	52	GP-1/9-100	51	K-156-6	185
E-110-ECO	201	GI-1/3-100	52	GP-1/9-65	51	K-15-P	185
E-4	150	GI-1/3-150	52	GP-2/1-200	51	K-15-PS	185
E-5	150	GI-1/3-20	52	GPPFP-1/1	51	K-15-S	185
E-5-ECO	150	GI-1/3-20	48	GPPFP-1/2	51	K-204	185
E-6	151	GI-1/3-200	52	GPPFP-2/1	51	K-204-5	185
E-6-ECO	151	GI-1/3-40	52	GPT 1/1	51	K-205	185
EC-1	113	GI-1/3-65	52	GPT 1/2	51	K-205-5	185
EC-10	2	GI-1/4-100	52	GPT 1/3	51	K-206	185
EC-10	113	GI-1/4-150	52	GPT 1/4	51	K-206-5	185
EC-105	115	GI-1/4-20	48	GPT 1/6	51	KBV-100	190
EC-35	115	GI-1/4-20	52	GPT 1/9	51	KBV-150	190
EC-5-45	114	GI-1/4-200	52	GPT 2/1	51	KBV-200	190
EC-55	115	GI-1/4-40	52	H		KL-100	190
EC-710	199	GI-1/4-65	52	H-120NV	146	KL-25	190
EC-711	199	GI-1/6-100	53	H-12SR	146	KL-50	190
EC-712	199	GI-1/6-150	53	H-140NV	146	KL-55	190
EC-713	199	GI-1/6-200	53	H-14SR	146	KM-104	187
EC-714	199	GI-1/9-100	53	H-16SR	146	KM-104-5	187
EC-715	199	GI-1/9-65	53	H-18SR	146	KM-105	187
ECU-100	116	GI-2/1-100	52	H-20SR	146	KM-105-5	187
ECU-15	199	GI-2/1-150	52	H-22R	146	KM-106	187
ECU-25	116	GI-2/1-20	52	H-24R	146	KM-106-5	187
ECU-50	116	GI-2/1-20	48	H-26R	146	KM-124	187
ET-10	127	GI-2/1-200	52	H-28R	146	KM-124-S	187
ET-100	127	GI-2/1-40	52	H-E10	146	KM-125	187

K-S

KM-125-5	187
KM-126	187
KM-126-5	187
KM-154	187
KM-154-5	187
KM-155	187
KM-155-5	187
KM-156	187
KM-156-5	187
KM-204	187
KM-204-5	187
KM-205	187
KM-205-5	187
KM-206	187
KM-206-5	187
KP-104	188
KP-105	188
KP-106	188
KP-124	188
KP-125	188
KP-126	188
KP-154	188
KP-155	188
KP-156	188
KP-204	188
KP-205	188
KP-206	188
KP-250	189
KP-300	189
KP-350	189
KP-400	189
KP-500	189
KTA-105	188
KTA-106	188
KTA-107	188
KTA-108	188

L

LM-1	111
LM-10	107
LM-10-P	107
LM-11	108
LM-1-1	108
LM-1-2	108
LM-1-3	108
LM-2	112
LM-21	109
LM-2-1	108
LM-21-1	111
LM-21-2	110
LM-21-3	110
LM-21-4	110
LM-22	109
LM-2-2	108
LM-23	109
LM-23-1	111
LM-23-2	110
LM-24	109
LM-25	111
LM-26	109
LM-27	110
LM-2-P	112
LM-4	112
LM-5	112
LMP-4	112
LMP-5	112

M

MC-E300	74
MC-E350	74
MC-M350	74
MC-220-AF	75
MC-250-C	75
MC-300-E	75
MC-350-I	75
MC-250-VOL	76
MC-2530	76
MC-3	82
MC-300-VOL	76
MC-5	83
MC-8	83
MC-CD-3	82
MC-CD-5	82
MC-CL-3	82
MC-CL-5	82
MC-CP-3	82
MC-CP-5	82
ME-L14	139
ME-L5	139

ME-L7	139
ME-L8	139
ME-L8V	139
MH-1	136
MH-10	137
MH-101	200
MH-102	200
MH-103	201
MH-104	201
MH-105	200
MH-107	200
MH-108	201
MH-109	201
MH-110	201
MH-111	201
MH-112	201
MH-13	137
MH-15	137
MH-1-R	136
MH-2	136
MH-20	138
MH-21	138
MH-22	138
MH-23	138
MH-25	138
MH-3	136
MH-4	136
MH-5	136
MH-6	137
MH-6-1	200
MH-7	137
MH-7-1	200
MH-8	136
MH-8-1	200
MH-9	136
MH-9-1	200
MP-12MEC-M	64
MP-12MEC-T	64
MP-22 EURO-M	65
MP-22 EURO-T	65
MP22 MEC-M	66
MP-22 MEC-T	66
MP-22RE-T	68
MP-32 MEC-M	67
MP-32 MEC-T	67
MP-32RE-T	69
MP-8-M	70
MPE-18	84
MPP-10	85
MPQ-02	78
MPQ-MOZ-15	77
MPQ-MOZZARELLA	77
MPQV-5-M	79
MPQV-5-T	79
MR-1	88
MR-10	90
MR-10-1	90
MR-103-I	160
MR-104-I	160
MR-105-I	160
MR-107-N	159
MR-108-N	159
MR-109-N	159
MR-11	90
MR-110	159
MR-115-I	160
MR-119-I	160
MR-12	90
MR-13	90
MR-14	90
MR-15	92
MR-1-ECO	88
MR-2	89
MR-20	89
MR-201	200
MR-201-ECO	200
MR-202	200
MR-202-ECO	200
MR-203	200
MR-204	200
MR-205	200
MR-206	200
MR-206-ECO	200
MR-207	200
MR-208	200
MR-209	200
MR-210	200

MR-215	200
MR-3	89
MR-30	89
MR-4	88
MR-40	89
MR-45	89
MR-4-500	88
MR-4-500-ECO	88
MR-46	89
MR-4-600	88
MR-47	89
MR-49	89
MR-4-ECO	88
MR-5	90
MR-50	89
MR-6	90
MR-60	89
MR-80	91
MR-9	91
MR-90	91
MRI-5	90
MRI-6	90
MRIT-5	90
MRIT-6	90
MSE-10	78
MT-152	98
MT-192	98
MT-270	99
MTB-15	99
MTB-20	99
MTB-27	99
MTM-1/2	99
MTM-1/4	99
MV-10	93
MV-16	93
MV-21	93
MVS-100	94
MVS-330	94
MVS-430	93

N

N-20	152
N-21	152
N-22	152
N-3	152
N-30	152
N-31	152
N-32	152
N-9	152

O

OR-2	128
OR-2M	128
OZ-10G	113

P

PB-1	103
PB-10	105
PB-11	105
PB-12	104
PB-1-M	103
PB-2	103
PB-21	103
PB-21N	103
PB-22	104
PB-22N	104
PB-23	104
PB-23N	104
PB-24	104
PB-24N	104
PB-3	103
PB-30	105
PB-40	105
PB-50	105
PB-7	104
PB-70	105
PB-8	104
PB-9	104
PH-3	138
PH-4	138
PH-5	138
PH-6	138
PH-7	138
PH-8	138
PR-20	145
PR-25	145
PS-60	138
PS-70	138
PS-80	138

R

R-100	158
R-10-BE	154
R-10-BEP	154
R-10-G	154
R-10-GP	154
R-20	154
R-2020-AZ	156
R-2020-R	156
R-2020-V	156
R-2021	156
R-2032-AZ	156
R-2032-R	156
R-2032-V	156
R-2054-AZ	156
R-2054-R	156
R-2054-V	156
R-21	154
R-22	154
R-30	155
R-31	155
R-40	44
R-50	157
R-75	158
R-80	157
RB-4-A	150
RB-4-AZ	150
RB-4-B	150
RB-4-R	150
RB-4-T	150
RB-4-V	150
R-CI	158
R-CI110	157
RE-5-B	151
RE-5-N	151
RE-6-B	151
RE-6-N	151
RE-7	151
RE-8	151
R-PM	158
R-PM110	157
RT-5-A	128
RT-5-AZ	128
RT-5-B	128
RT-5-R	128
RT-5-V	128
RT-6-A	128
RT-6-AZ	128
RT-6-B	128
RT-6-R	128
RT-6-V	128

S

SB-1000	91
SB-1001	199
SB-200	91
SB-201	199
SB-202	199
SB-300	91
SB-301	199
SB-302	199
SB-400	91
SB-400-ECO	91
SB-401	199
SB-402	199
SB-451	199
SB-500	91
SB-500-ECO	91
SB-501	199
SB-502	199
SB-600	91
SB-601	199
SB-602	199
SBM-500	92
SBM-505	92
SBPA-450	92
SBPA-451	199
SBPA-600	92
SBPA-601	199
SCA-1600	73
SCA-1740	73
SCA-1750	73
SCA-1985	73
SCA-2120	73
SCA-2340	73
SCA-2520	73
SCA-2930	73
SCO-1600	73

SCO-1740	73	V-FA454520PL	11	V-H33331.5	8	V-H60404	9
SCO-1750	73	V-FA505020PL	11	V-H33332	8	V-H60405	9
SCO-1985	73	V-FA604020PL	11	V-H33333	8	V-H60409	10
SCO-2120	73	V-FA644520PL	11	V-H33334	9	V-H65455	9
SCO-2340	73	V-FA705020PL	11	V-H33335	9	V-H70505	9
SCO-2520	73	V-FI1005020PL	11	V-H3514	10	V-H75251.5	8
SCO-2930	73	V-FI21005020PL	11	V-H355	10	V-H75252	8
SHU-1600	73	V-FI2404020PL	11	V-H359	10	V-H75253	8
SHU-1740	73	V-FI2454520PL	11	V-H4014	10	V-H75254	9
SHU-1750	73	V-FI2505020PL	11	V-H40201.5	8	V-H75255	9
SHU-1985	73	V-FI2604020PL	11	V-H40202	8	V-H75331.5	8
SHU-2120	73	V-FI2644520PL	11	V-H40203	8	V-H75332	8
SHU-2340	73	V-FI2705020PL	11	V-H40204	9	V-H75333	8
SHU-2520	73	V-FI404020PL	11	V-H40205	9	V-H75334	9
SHU-2930	73	V-FI454520PL	11	V-H40251.5	8	V-H75335	9
SJ-10	141	V-FI505020PL	11	V-H40252	8	V-H80405	9
SJ-12	142	V-FI604020PL	11	V-H40253	8	V-H90455	9
SJ-15	141	V-FI644520PL	11	V-H40254	9	V-HAGU14	10
SJ-16	141	V-FI705020PL	11	V-H40255	9	V-HAGU5	10
SJ-18	141	V-FS454520PL	12	V-H40301.5	8	V-HAGU9	10
SJ-20	140	V-FS604020PL	12	V-H40302	8	V-HC10020	16
SJ-4	140	V-FS705020PL	12	V-H40303	8	V-HC3320	16
SJ-500	141	V-G1005025E	6	V-H40304	9	V-HC5020	16
SJ-5-M	140	V-G443210E	6	V-H40305	9	V-HG40302V	19
SJ-600	141	V-G443215E	6	V-H4031.5	8	V-HRP-40302S	17
SJ-600-R	141	V-G443220E	6	V-H403314	10	V-I1005025E	4
SJ-6-B	140	V-G443225E	6	V-H40332	8	V-I21005025E	4
SJ-8	140	V-G604015E	6	V-H40333	8	V-I2404025E	4
SJ-9	140	V-G604025E	6	V-H40334	9	V-I2444425E	4
SM-5	102	V-G644425E	6	V-H40335	9	V-I2505025E	4
SM-6	102	V-G705025E	6	V-H40339	10	V-I2604025E	4
SM-700	102	V-G804025E	6	V-H40401.5	8	V-I2644425E	4
SPI-6	18	V-G806015E	6	V-H40402	8	V-I2705025E	4
T		V-G884425E	6	V-H40403	8	V-I2804025E	4
T-002	147	V-GOMA	3	V-H40404	9	V-I2884425E	4
T-003	147	V-GUIA-40	3	V-H40405	9	V-I404025E	4
T-005	147	V-H100251.5	8	V-H40409	10	V-I444425E	4
T-007	147	V-H100252	8	V-H405	10	V-I505025E	4
T-008	148	V-H100253	8	V-H409	10	V-I604025E	4
T-009	147	V-H100254	9	V-H45455	9	V-I644425E	4
T-012	148	V-H100255	9	V-H45459	10	V-I705025E	4
T-050	148	V-H100331.5	8	V-H50251.5	8	V-I804025E	4
T-360	144	V-H100332	8	V-H50252	8	V-I884425E	4
TA-002	148	V-H100333	8	V-H50253	8	V-K40405	13
TC-180	172	V-H100334	9	V-H50254	9	V-K40409	13
TC-200	172	V-H100335	9	V-H50255	9	V-K45455	13
TC-220	172	V-H100505	9	V-H50301.5	8	V-K45459	13
TC-240	172	V-H150251.5	8	V-H50302	8	V-K50505	13
TC-280	172	V-H150252	8	V-H50303	8	V-K50509	13
TF-200	172	V-H150253	8	V-H50304	9	V-K540405	13
TF-225	172	V-H150254	9	V-H50305	9	V-K540409	13
TM-430	173	V-H150255	9	V-H50331.5	8	V-K545455	13
TM-500	173	V-H150331.5	8	V-H503314	10	V-K545459	13
TP-210	172	V-H150332	8	V-H50332	8	V-K550505	13
TP-230	172	V-H150333	8	V-H50333	8	V-K550509	13
TP-250	172	V-H150334	9	V-H50334	9	V-K560405	13
TT-265	172	V-H150335	9	V-H50335	9	V-K560409	13
V		V-H2001001.5	8	V-H50339	10	V-K570505	13
V-A1005025E	3	V-H2001002	8	V-H50401.5	8	V-K570509	13
V-A404015E	3	V-H2001003	8	V-H50402	8	V-K60405	13
V-A404025E	3	V-H2001004	9	V-H50403	8	V-K60409	13
V-A443215E	3	V-H2001005	9	V-H50404	9	V-K70505	13
V-A444425E	3	V-H200251.5	8	V-H50405	9	V-K70509	13
V-A505025E	3	V-H200252	8	V-H50501.5	8	V-L240405	12
V-A604015E	3	V-H200253	8	V-H50502	8	V-L240409	12
V-A604025E	3	V-H200254	9	V-H50503	8	V-L245455	12
V-A644425E	3	V-H200255	9	V-h50504	9	V-L245459	12
V-A705025E	3	V-H200331.5	8	V-H50505	9	V-L250505	12
V-A804025E	3	V-H200332	8	V-H50509	10	V-L250509	12
V-A806015E	3	V-H200333	8	V-H60251.5	8	V-L260405	12
V-A884425E	3	V-H200334	9	V-H60252	8	V-L260409	12
V-BPGD	7	V-H200335	9	V-H60253	8	V-L270505	12
V-BPGDI	7	V-H25191.5	8	V-H60254	9	V-L270509	12
V-F404020PL	10	V-H25192	8	V-H60255	9	V-MC60505	19
V-F404025PL	10	V-H25193	8	V-H60301.5	8	V-MC60505-R	19
V-F454520PL	10	V-H25194	9	V-H60302	8	V-MI10060C	14
V-F454525PL	10	V-H25195	9	V-H60303	8	V-MI10060S	14
V-F505020PL	10	V-H30201.5	8	V-H60304	9	V-MI10070C	14
V-F505025PL	10	V-H30202	8	V-H60305	9	V-MI10070S	14
V-F604020PL	10	V-H30203	8	V-H60331.5	8	V-MI15060C	14
V-F604025PL	10	V-H30204	9	V-H60332	8	V-MI15060S	14
V-F644520PL	10	V-H30205	9	V-H60333	8	V-MI15070C	14
V-F644525PL	10	V-H33191.5	8	V-H60334	9	V-MI15070S	14
V-F705020PL	10	V-H33192	8	V-H60335	9	V-MI20060C	14
V-F705025PL	10	V-H33193	8	V-H60401.5	8	V-MI20060S	14
V-FA1005020PL	11	V-H33194	9	V-H60402	8	V-MI20070C	14
V-FA404020PL	11	V-H33195	9	V-H60403	8	V-MI20070S	14

V-Z

V-MI5050	14	V-PORACE-44	2	X-2902	43
V-MI7050	14	V-PORACE-50	2	X-2903	43
V-MIS	14	V-PORMAD	2	X-2904	43
V-MM10060XC	15	V-PORPOLB	2	X-2905	43
V-MM10060XS	15	V-PORPOLR	2	X-2906	43
V-MM10070XC	15	V-PR	3	X-2907	43
V-MM10070XS	15	V-S443225E	5	X-2909	43
V-MM15060XC	15	V-S444425E	5	X-2910	43
V-MM15060XS	15	V-S604025E	5	X-6886	43
V-MM15070XC	15	V-S705025E	5	X-9005	43
V-MM15070XS	15	V-SP2B	19	Y	
V-MM20060XC	15	V-SP2M	19	Y-30201	10
V-MM20060XS	15	V-SP2R	19	Y-40302	10
V-MM20070XC	15	V-T50355	6	Y-50302	10
V-MM20070XS	15	V-T50405	6	Y-60402	10
V-MP10060XC	15	V-TP30202	19	Z	
V-MP10060XS	15	V-TP35252	19	Z-10	202
V-MP10070XC	15	V-VALDILLA	3	Z-11	202
V-MP10070XS	15	W		Z-11-U	202
V-MP15060XC	15	W-120	117	Z-15	202
V-MP15060XS	15	W-240	117	Z-151	129
V-MP15070XC	15	W-28	118	Z-20	202
V-MP15070XS	15	W-60	117	Z-20-F	202
V-MP20060XC	15	W-80	117	Z-21	202
V-MP20060XS	15	W-81	118	Z-40	202
V-MP20070XC	15	WI-110	120	Z-420-MD	129
V-MP20070XS	15	WI-35	118	Z-430-MD	129
V-MX10050XC	16	WI-60	120	Z-440-MD	129
V-MX10050XS	16	WI-70	119	Z-600	129
V-MX10060XC	16	WI-75	119	Z-700	129
V-MX10060XS	16	WI-90	119	Z-780	129
V-MX10070XC	16	X		Z-911	130
V-MX10070XS	16	X-0024	41	Z-911-A	130
V-MX15050XC	16	X-0100	42	Z-911-N	130
V-MX15050XS	16	X-0101	42	Z-918	130
V-MX15060XC	16	X-0102	42	Z-918-A	130
V-MX15060XS	16	X-0200	42	Z-918-N	130
V-MX15070XC	16	X-0201	42	Z-930	132
V-MX15070XS	16	X-0202	42	Z-930-A	132
V-MX20050XC	16	X-0203	42	Z-950	131
V-MX20050XS	16	X-0204	42	Z-950-A	131
V-MX20060XC	16	X-0210	42	Z-960	131
V-MX20060XS	16	X-0724	41	Z-960-A	131
V-MX20070XC	16	X-2500	40		
V-MX20070XS	16	X-2503	40		
V-O3510E	6	X-2504	40		
V-O3515E	6	X-2505	40		
V-O3520E	6	X-2509	40		
V-O404015E	5	X-2514	40		
V-O404025E	5	X-2515	41		
V-O444410E	5	X-2530	41		
V-O444420E	5	X-2800	40		
V-O444425E	5	X-2801	40		
V-O505025E	5	X-2804	40		
V-PF	3	X-2900	43		
V-PORACE-40	2	X-2901	43		

CONDICIONES GENERALES DE VENTA

RECLAMACIONES

- La mercancía viajará por cuenta y riesgo del comprador debiendo notificar cualquier reclamación antes de 24 horas y haciéndolo constar ante la empresa de transportes.
- Rogamos hacer constar siempre en la entrega del transportista "SALVO EXAMEN" si no se puede revisar la mercancía en ese momento.

DEVOLUCIONES

- Devoluciones de mercancía, siempre por nuestra agencia habitual.
NO SE ACEPTARÁN DEVOLUCIONES sin antes comunicarlo a J-2 IMPORTACIONES Y DISTRIBUCIONES por teléfono, fax o mail.

PEDIDOS MÍNIMOS

- Pedidos mínimos 100 euros netos. Inferiores se cargarán 10 euros gastos de administración.

CONFLICTOS

- En caso de litigio se resolverán en el juzgado correspondiente a la plaza del vendedor con renuncia de cualquier otro fuero.

GENERAL CONDITIONS OF SALE

COMPLAINTS

- The goods travel at the risk of the purchaser who must notify any claim within 24 hours and shall communicate first the carrier.
- Please always record in delivering carrier "SALVO REVIEW" if you can not inspect the goods at that time.

RETURNS

- Returns of merchandise provided by our usual agency.
NO RETURNS WILL BE ACCEPTED without first communicating it to J-2 IMPORTS AND DISTRIBUTIONS by phone, fax or mail.

MINIMUM ORDERS

- Minimum order 100 euros net. Lower ones are charged 10 euros for administrative expenses.

CONFLICTS

- In case of dispute will be resolved in the seller's corresponding post waiving any other jurisdiction.

CONDITIONS GENERALES DE VENTE

PLAINTES

- Le voyage des marchandises sera au risque de l'acheteur qui doit notifier toute réclamation dans les 24 heures et doit notifier d'abord au transporteur.
- Nous vous prions de bien consigner au transporteur la clause "SAUF EXAMEN" si vous ne pouvez pas inspecter les marchandises à ce moment-là.

RETOURS

- Les retours de marchandises seront réalisés par notre agence habituelle.
AUCUN RETOUR NE SERA ACCEPTÉ sans avoir être notifié à J-2 IMPORTATIONS ET DISTRIBUTIONS par téléphone, fax ou courrier.

COMMANDES MINIMALES

- Commande minimum de 100 euros net. Frais administratifs de 10 euros sont facturés pour des ordres inférieurs.

CONFLITS

- En cas de litige sera résolu judiciairement dans la place correspondante au vendeur, renonçant à toute autre juridiction.



J2 IMPORTACIONES Y DISTRIBUCIONES

Turó de la Trinitat, 4 - 6
08033 Barcelona - España
93 311 54 20 | 93 311 59 50
j-2@j-2.es
pedidos@j-2.es

Pol. Industrial Can Milans
C/ Can Milans, 47
08110 MONTACADA I REIXAC
Barcelona - España

www.j-2.es